

## Schwinn IC3, IC4: How can I tighten my handlebar or handlebar post?

ID: 13901.2

Follow this troubleshooting guide to help resolve issues involving the handlebar on the Schwinn IC3 and IC4 indoor cycling bikes.

Some common complaints may include:

- Handlebar is loose
- Handlebar Post is loose

**Follow these steps to troubleshoot the issue**



[\(BowFlex® | How to Adjust the Seat and Handlebars on Your IC Bike\)](#)

1. Tighten the Handlebar and Handlebar Post Adjustment Knobs (**reference 1**). The handle on the Handlebar Post Adjustment Knob will face downward once fully tightened. There is a locking pin that will engage when the Handlebar Post Adjustment Knob has been fully tightened [\[13901.A\]](#).

(Reference 1)

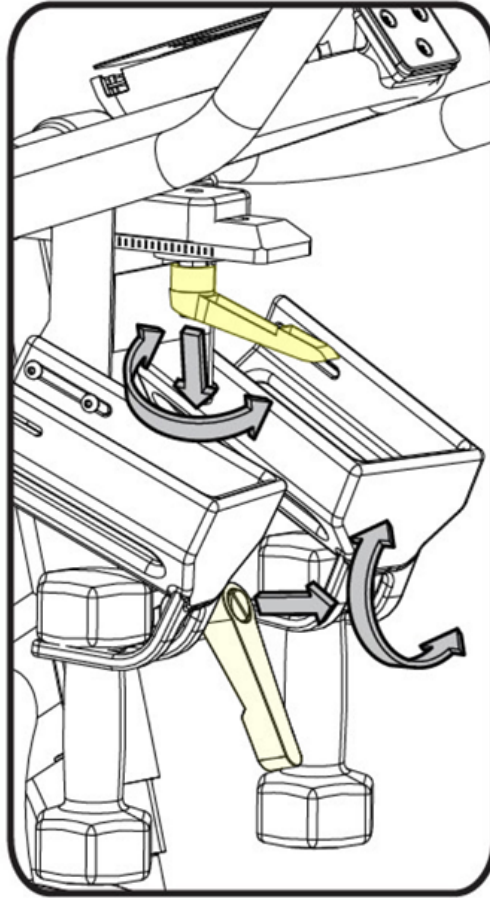

*The Handlebar Adjustment Knob is located directly underneath the handlebars.*

*The Handlebar Post Adjustment Knob is located on the front of the bike between the dumbbell holders.*

2. If the issue persists, disassemble the handlebar assembly. Loosen the Handlebar Post Adjustment Knob and remove the handlebar assembly from the frame. Fully loosen the Handlebar Adjustment Knob and remove the Handlebar from the Handlebar Post.
3. Reassemble the handlebar assembly. Insert the Handlebar Post into the frame and engage the Handlebar Post Adjustment Knob with the holes on the Handlebar Post (**reference 2**). Ensure that the handle on the Handlebar Post Adjustment Knob points downward after tightening. Place the Handlebar on the Handlebar Post and fully tighten the Handlebar Adjustment Knob (**reference 3**). When fully tightened, the handle will point forward. Instructions on assembling the handlebar assembly can be found in the [assembly manual \[13901.B\]](#).

**(Reference 2)**

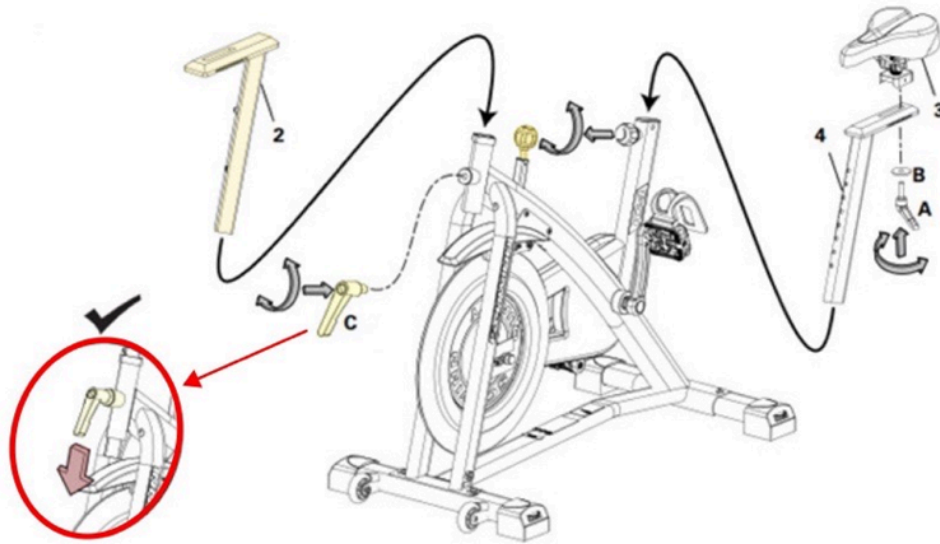

The Handlebar Post (2) should be inserted into the frame with the Handlebar Post Adjustment Knob engaged in the holes of the post. The handle on the knob should be pointed downward once completely tightened.

(Reference 3)

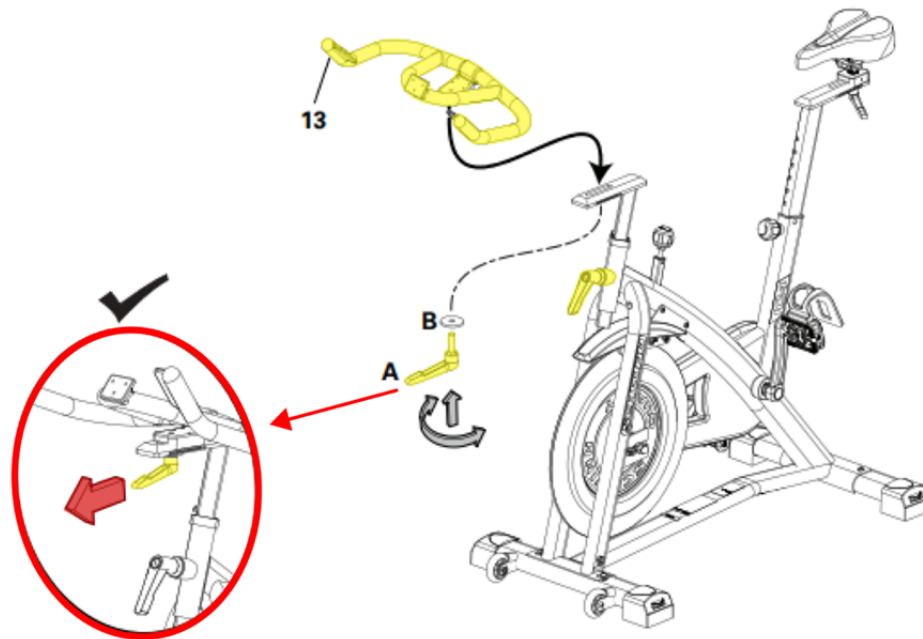

The Handlebar (13) should be secured onto the Handlebar Post (2). Tighten the Handlebar Adjustment Knob, it will point forward once completely tightened.

**Need additional assistance?**

## 1 Customer Care Contact Information

Please contact Customer Care at **1-800-605-3369** for additional help or to order replacement parts. Some replacement parts may also be available for purchase [online here](#). A list of part numbers referenced within this guide can be located at the bottom of this page.

**Customer Care - Hours of Operation:**

Monday - Friday 6:00am - 5:00pm PST

*The replacement part will be provided to you at no cost assuming your machine meets the warranty eligibility requirements. A Customer Care Agent will be able to assess your current warranty eligibility and provide you with your options.*

*Please note that if you did not purchase your machine directly from BowFlex, Schwinn, or Nautilus, we will need a copy of your purchase receipt in order to register your machine for warranty.*

## 2 Contact Tech Team / Advanced Troubleshooting

***If the issue was not resolved in the steps listed, contact the Tech Team or send an Advanced Troubleshooting case.***

**Submit a Case with case type Advanced Troubleshooting**