

Table of Contents

Section Code	Section	Page Number
1	Important Safety Instructions	2
1	Safety Warning Labels and Serial Number	3
1	Specifications	4
1	Grounding Instructions	5
1	Moving and Storing the Machine	6
1	Leveling the Machine	6
1	Using the JRNY™ app with your machine	7
1	USB Charging	7
1	Bluetooth® Audio (Input)	7
1	Bluetooth® Heart Rate Monitor (not supplied)	7
1	Maintenance	9
1	Cleaning	9
1	Maintenance Parts	10
1	Troubleshooting	12
1	Console Setup Mode	15
1	Electrical Wiring	17
1	Replacement Procedure Skill Level	18
	Mechanical / Modification Procedures	
2	Calibrate the Incline	19
3	Calibrating the Resistance	22
	Part Replacement	
4	Replace the Cables	25
5	Replace the Console	38
6	Replace the Console Mast	42
7	Replace the Crank Arm	48
8	Replace the Drive Belt	54
9	Replace the Drive Pulley	66
10	Replace the Idler Pulley	80
11	Replace the Incline (Lift) Motor	93
12	Replace the Offline Power Supply	103
13	Replace the Resistance Sensor	108
14	Replace the Roller Wheels	113
15	Replace the Sensor Hub	115
16	Replace the Servo Motor	124
17	Replace the Shrouds	128
18	Replace the Speed Sensor	143
19	Replace the Upper Handlebars	148

NOTICE: This document provides important safety instructions, adjustments, and general troubleshooting information for the maintenance of the Schwinn™ 490 / 590e Ellipticals.

If you need assistance, please contact Customer Service (if purchased in US/Canada) or your local distributor (if purchased outside US/Canada). To find your local distributor, go to: www.nautilusinternational.com

⚠ This icon means a potentially hazardous situation which, if not avoided, could result in death or serious injury. Read and understand all Warnings on this machine.

Nautilus, Inc., www.nautilus.com, 5415 Centerpoint Parkway, Groveport, OH 43125 U.S.A. - Customer Service: North America (800) 605-3369, csnls@nautilus.com | outside U.S. www.nautilusinternational.com | Printed in China | © 2023 Nautilus, Inc. | Schwinn and the Schwinn logo are trademarks owned or licensed by Nautilus, Inc., registered or otherwise protected by common law in the United States and other nations. | **ORIGINAL DOCUMENT - ENGLISH VERSION ONLY**

Important Safety Instructions

⚠ This icon means a potentially hazardous situation which, if not avoided, could result in death or serious injury. Read and understand all Warnings on this machine.

Before servicing or using this equipment, obey the following warnings:

⚠ Read and understand the Service Manual before working on the machine. Failure to obey the instructions and safety warnings could cause injury to the service technician or bystanders.

⚠ DANGER To reduce the risk of electrical shock or unsupervised usage of the equipment, always unplug the power cord from the wall outlet and wait 5 minutes before cleaning, maintaining or repairing this machine. Place the power cord in a secure location.

- Keep bystanders and children away from the product being serviced at all times.
- Make sure that the repair is done in an appropriate work space away from foot traffic and exposure to bystanders.
- Some components of the equipment can be heavy or awkward. Enlist the service of a second person when you do maintenance steps involving these components. Do not try to do heavy or awkward steps on your own.
- Use only replacement parts and hardware that are supplied or approved by Nautilus. Failure to use Nautilus-approved replacement parts can adversely affect the safety and functionality of the equipment creating a risk to users and will void the warranty.
- Be sure that all warning stickers and instructional placards applied to the product stay present and in good condition when doing maintenance or replacing components. If at any time the Warning labels become loose, unreadable or dislodged, replace the labels. If purchased in US/Canada, contact Customer Service for replacement labels. If purchased outside US/Canada, contact your local distributor for them.
- Do not try to change the design or functionality of the machine being serviced as this can adversely affect user safety and will void the warranty.
- Do not put the machine back in service until all shrouds, instructions, warning labels and correct functionality have been verified and tested for correct performance.

• SAVE THESE INSTRUCTIONS

SAFETY WARNING LABELS AND SERIAL NUMBER

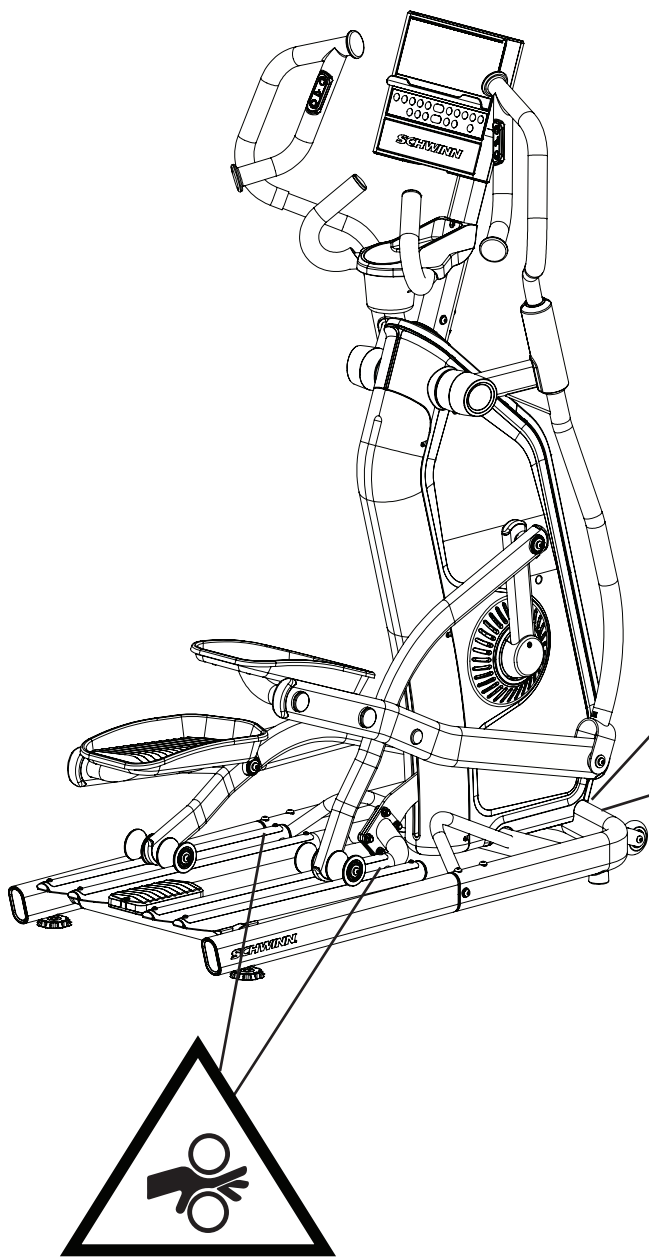

Product Specification and Serial Number

WARNING!

Read, understand and obey all warnings on this machine. Risk of personal injury. Keep children away. Not intended for use by anyone under 14 years of age. Prior to use, read and understand the owners manual. Injury or death is possible if caution is not used while using this machine. The maximum user weight for this machine is 330 lbs (150 kg). Care should be taken when mounting and dismounting the stationary exercise equipment. Before dismounting, bring the machine to a complete stop. The heart rate displayed is an approximation and should be used for reference only. This exercise unit does not have a freewheel and pedal speed must be reduced in a controlled manner. For Consumer Use Only. Consult a physician prior to using any exercise equipment.

(Label on Schwinn™ 490 machine is available in English and French Canadian only.)

SPECIFICATIONS

Power Requirements: 120V

Operational Voltage: 110-127V AC, 60Hz
 Operating Current: 2A

220V

220V - 240V AC, 50Hz
 2A

Maximum User Weight:

150 kg (330 lb)

Total Surface Area (footprint) of equipment:

12,723 cm²

Maximum Pedal Height - with full incline:

28.3 in (72 cm)

Machine Weight:

approx. 84.8 kg (187 lb)

This product complies with the European Radio Equipment Directive 2014/53/EU

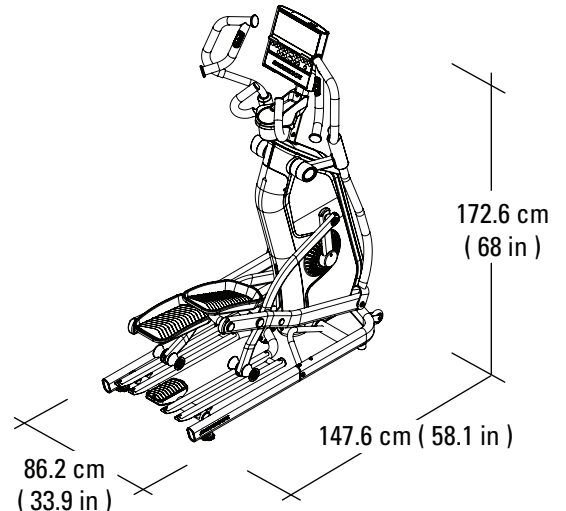

DO NOT dispose of this product as refuse. This product is to be recycled. For proper disposal of this product, please follow the prescribed methods at an approved waste center.

For safe operation, the location must be on a hard, level surface. Allow a minimum workout area of 82.1 in x 57.9 in (208.5 cm x 147.1 cm). Keep the workout area clear 0.6 m (24 in) along the side used to access the machine and to the rear of the machine. Be sure that the workout space you are utilizing has adequate height clearance, taking into consideration the height of the user and the maximum incline of the elliptical machine.

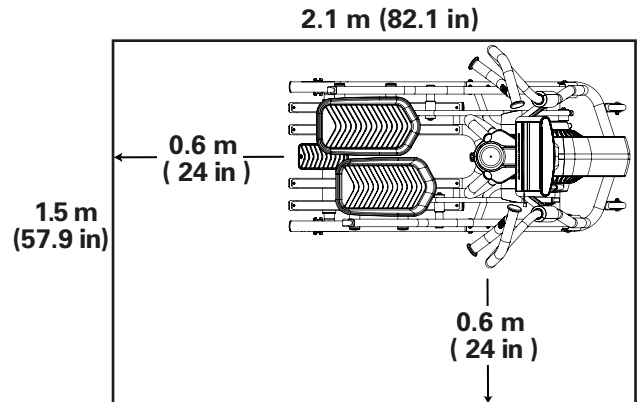

FCC Compliance

⚠ Changes or modifications to this unit not expressly approved by the party responsible for compliance could void the user's authority to operate the equipment.

The machine and power supply comply with Part 15 of the FCC rules. Operation is subject to the following two conditions: (1) This device may not cause harmful interference, and (2) this device must accept any interference received, including interference that may cause undesired operation.

Note: This machine and power supply have been tested and found to comply with the limits for a Class B digital device, pursuant to Part 15 of the FCC Rules. These limits are designed to provide reasonable protection against harmful interference in a residential installation. This equipment generates, uses and can radiate radio frequency energy and, if not installed and used in accordance with the instructions, may cause harmful interference to radio communications.

However, there is no guarantee that interference will not occur in a particular installation. If this equipment does cause harmful interference to radio or television reception, which can be determined by turning the equipment off and on, the user is encouraged to try to correct the interference by one or more of the following measures:

- Reorient or relocate the receiving antenna.
- Increase the separation between the equipment and receiver.
- Connect the equipment into an outlet on a circuit different from that to which the receiver is connected.
- Consult the dealer or an experienced radio/TV technician for help.

This product complies with the European Radio Equipment Directive 2014/53/EU

Grounding Instructions

This product must be grounded. If it should malfunction or break down, grounding provides a path of least resistance for electric current to reduce the risk of electric shock. This product is equipped with a cord having an equipment-grounding conductor and a grounding plug. The plug must be plugged into an appropriate outlet that is properly installed and grounded in accordance with all local codes and ordinances.

⚠ DANGER

Improper connection of the equipment-grounding conductor can result in a risk of electric shock. Check with a qualified electrician or serviceman if you are in doubt as to whether the product is properly grounded. Do not modify the plug provided with the product – if it will not fit the outlet, have a proper outlet installed by a qualified electrician.

If you connect the machine to an outlet with GFI (ground fault interrupt) or AFI (arc fault interrupt), machine operation can cause the circuit to trip.

⚠ This machine is for use on a nominal 120-V circuit, and has a grounding plug that looks like the plug illustrated below. A temporary adapter that looks like the adapter illustrated may be used to connect this plug to a 2-pole receptacle as shown if a properly grounded outlet is not available.

The temporary adapter should be used only until a properly grounded outlet can be installed by a qualified electrician. The tab for the grounding screw must be connected to a permanent ground such as a properly grounded outlet box cover. Whenever the adapter is used, it must be held in place by a metal screw.

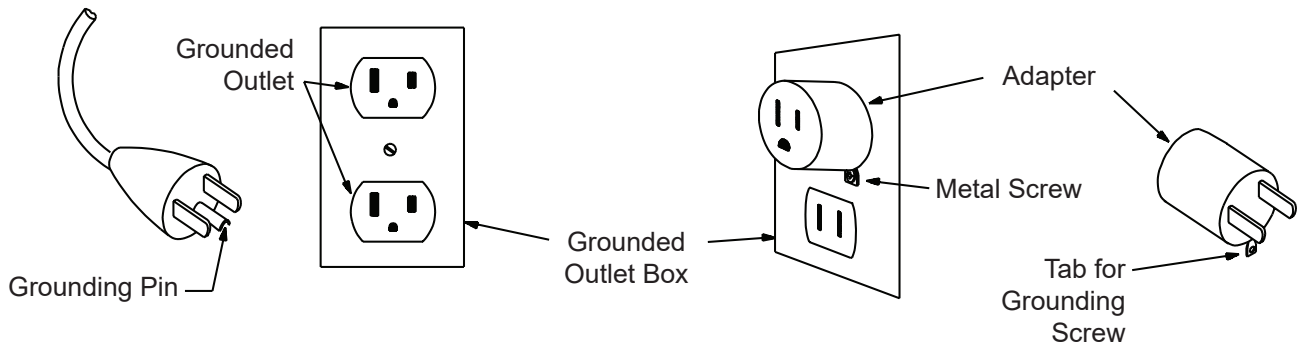

Earthing Instructions (for a 220-240V AC system)

This product must be electrically earthed. If a malfunction occurs, correct earthing decreases the risk of electric shock. The power cord is equipped with an equipment-earthing conductor, and must be connected to an outlet that is properly installed and earthed.

⚠ DANGER

The electrical wiring must comply with all applicable local and provincial standards and requirements. Incorrect connection of the equipment-earthing conductor can result in a risk of electric shock. Consult a licensed electrician if you are not sure that the machine is correctly earthed. Do not change the plug on the machine – if it does not fit the outlet, have a correct outlet installed by a licensed electrician.

If you connect the machine to an outlet with RCBO (Residual-Current circuit Breaker with Overload protection), machine operation can cause the circuit to trip. A Surge Protector Device is recommended to protect the machine.

⚠ If a Surge Protector Device (SPD) is used with this machine, be sure that it matches the power rating of this equipment (220-240V AC). Do not connect other appliances or devices to the surge protector in combination with this machine.

Moving the Machine

Use the Transport Handle / Rear Step and Transport Wheels to move the machine. The Transport Handle / Rear Step is located in the middle of the Rail Assembly at the rear of the machine. Tilt the machine forward by lifting upward with the Transport Handle / Rear Step until the weight is on the Transport Wheels.

Roll the machine on the transport wheels to a new location. Lower your machine slowly into its new location without injury to your head or fingers.

⚠ Do not use the handlebars, Console Mast, or the Console to lift or move the machine. Injury to you or damage to the machine can occur.

The machine may be moved by one or more persons depending on their physical abilities and capacities. Make sure that you and others are all physically fit and able to move the machine safely.

Place the machine on a clean, hard, level surface, free from unwanted material or other objects that may hamper your ability to move freely. A rubber mat should be used below the machine to prevent the release of static electricity and protect your flooring.

To prevent unsupervised operation of the machine always turn the power switch to Off and disconnect the power cord from the wall outlet and machine power input. Place the power cord in a secure location.

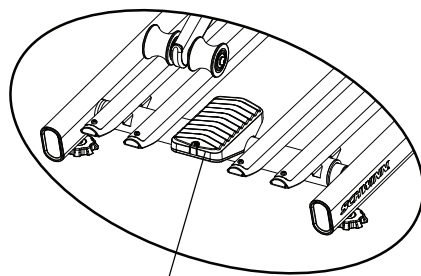

Transport Handle / Rear Step

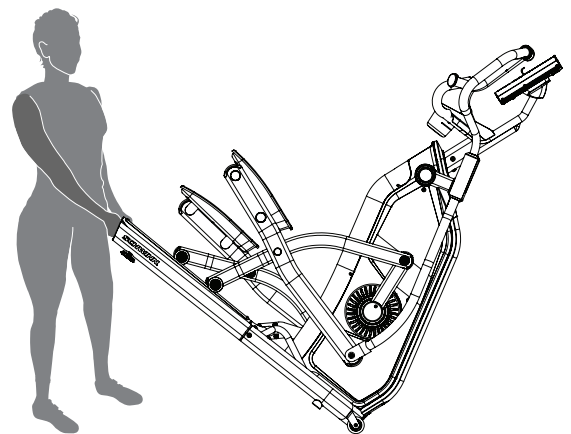

Leveling the Machine

The machine needs to be leveled if your workout area is uneven or if the Rail Assembly is slightly off the floor. To adjust:

1. Place the machine in your workout area.
2. Safely stand on the Rear Step for approximately 20 seconds.
3. Step off the machine.
4. Loosen the locking nuts and adjust the levelers until they all contact the floor.

⚠ Do not adjust the levelers to such a height that they detach or unscrew from the machine. Injury to you or damage to the machine can occur.

5. Adjust until the machine is level. Tighten the locking nuts.

Make sure the machine is level and stable before you exercise.

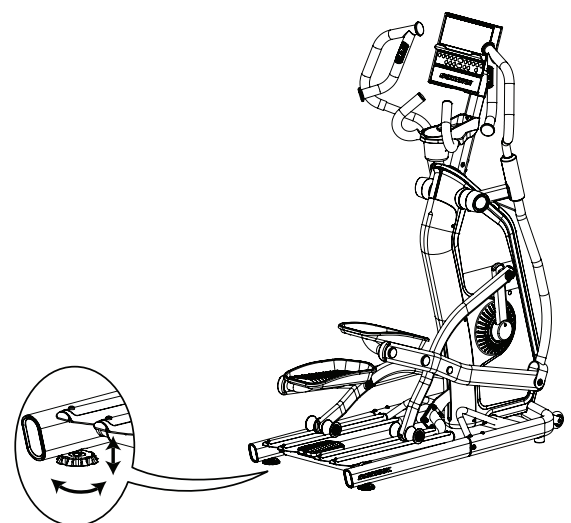

Using the “JRNY™” App with Your machine

This fitness machine is equipped with Bluetooth® connectivity and can be wirelessly connected for workouts using the “JRNY™” app. The app can be accessed with your JRNY™ membership.

Note: Do not connect this machine through your Bluetooth® settings on your device. Simply download the app, start a workout, and follow the instructions on the app.

1. Download the app named JRNY™. The app is available on the App Store and Google Play™.

Note: For a complete list of supported devices, review the app on the App Store or Google Play™.

2. Install the app.
3. Open the “JRNY™” app, and follow the instructions.
4. When done, tap on the red Bluetooth® icon in the upper right corner of the display.

Note: If Bluetooth® is not active on your device, follow the instructions to activate it.

5. A list of available machines will be displayed. Select your machine from the list of available machines.
6. The JRNY™ app is now ready for use.

Note: Once a Bluetooth® Heart Rate device is connected, that device is engaged to that machine. To use the Heart Rate device elsewhere, it must be disconnected. Follow the instructions provided in the app to disconnect.

USB Charging

If a USB Device is attached to the USB Port, the Port will attempt to charge the device. The power supplied from the USB Port may not be enough to operate the device and charge it at the same time.

Bluetooth® Audio (Input)

Your machine is able to play audio across a Bluetooth® connection from your smart device through the console speakers.

Note: Bluetooth® audio can only be streamed into the console.

Bluetooth® Low Energy (BLE) Heart Rate Monitor (not supplied)

Your fitness machine is equipped to be able to receive a signal from a Bluetooth® Low Energy (BLE) Heart Rate (HR) Monitor. When connected, the Console will display the Bluetooth® Heart Rate Monitor Connected icon. Follow the instructions provided with your Bluetooth® Low Energy (BLE) Heart Rate Monitor.

 **If you have a pacemaker or other implanted electronic device, consult your doctor before using a Bluetooth® Heart Rate Monitor.**

Note: Be sure to remove the protective cover (if provided) from the Heart Rate Sensor before use.

1. Put on your Bluetooth® Low Energy (BLE) Heart Rate monitor and activate it.
2. The Console will actively search for any monitors in the area, and will rapidly flash the Bluetooth® Heart Rate Monitor

* A JRNY™ membership is required for the JRNY™ experience – see www.schwinnfitness.com/jrny for details. For United States and Canada customers, you can obtain a JRNY™ membership by calling 888-986-5528 or visiting www.schwinnfitness.com/jrny. Where available (including the United States), you can also obtain a JRNY™ membership by downloading the JRNY™ app onto your phone or tablet and signing up within the downloaded app. JRNY™ memberships may not be available in all countries.

Connected icon.

Note: Any previously connected Heart Rate devices will be disconnected. However, if they are within range, the Console may find them again if unable to locate your Monitor.

3. When connected, the Bluetooth® Heart Rate Monitor Connected icon will flash with your pulse and your current heart rate value will be displayed on the Console. You are now ready to workout.

Note: Once a Bluetooth® Low Energy (BLE) Heart Rate device is connected, that device is engaged to that machine. To use the Heart Rate device elsewhere, it must be disconnected. Follow the instructions provided in the app to disconnect.

MAINTENANCE

Read all maintenance instructions fully before you start any repair work. In some conditions, an assistant is required to do the necessary tasks.

 **Equipment must be regularly examined for damage and repairs. The owner is responsible to make sure that regular maintenance is done. Worn or damaged components must be repaired or replaced immediately. Only manufacturer supplied components can be used to maintain and repair the equipment.**

If at any time the Warning labels become loose, unreadable or dislodged, replace the labels. If purchased in US/Canada, contact Customer Service for replacement labels. If purchased outside US/Canada, contact your local distributor for them.

 **To reduce the risk of electrical shock or unsupervised usage of the equipment, always unplug the power cord from the wall outlet and/or the machine and wait 5 minutes before cleaning, maintaining or repairing the machine. Place the power cord in a secure location.**

Daily: Before each use, examine the exercise machine for loose, broken, damaged, or worn parts. Do not use if found in this condition. Repair or replace all parts at the first sign of wear or damage. After each workout, use a damp cloth to wipe your machine and Console free of moisture.

Note: Avoid excessive moisture on the Console.

Weekly: Check for smooth roller operation. Wipe the machine to remove dust, dirt, or grime. Clean the rails and surface of the rollers with a damp cloth.
Apply silicone lubricant to a dry cloth and wipe the rails to eliminate roller noise.

 **Silicone lubricant is not intended for human consumption. Keep out of reach of children. Store in a safe place.**

Note: Do not use petroleum based products.

Monthly or after 20 hours: Make sure all bolts and screws are tight. Tighten if necessary.

NOTICE: If necessary, only use a mild dish soap with a soft cloth to clean the Console. Do not clean with a petroleum based solvent, automotive cleaner, or any product that contains ammonia. Do not clean the Console in direct sunlight or at high temperatures. Be sure to keep the Console free of moisture.

 **The Schwinn™ 490 machine is for home use only.**

When the Schwinn™ 590e machine is used in a Studio/Institutional environment, we recommend that the Pedals be replaced every year to maintain maximum user safety and performance. Only use replacement Pedals available from Nautilus. Other brands of Pedals may not be designed for this product, and can cause danger to users and bystanders, and will void the warranty.

Maintenance Parts

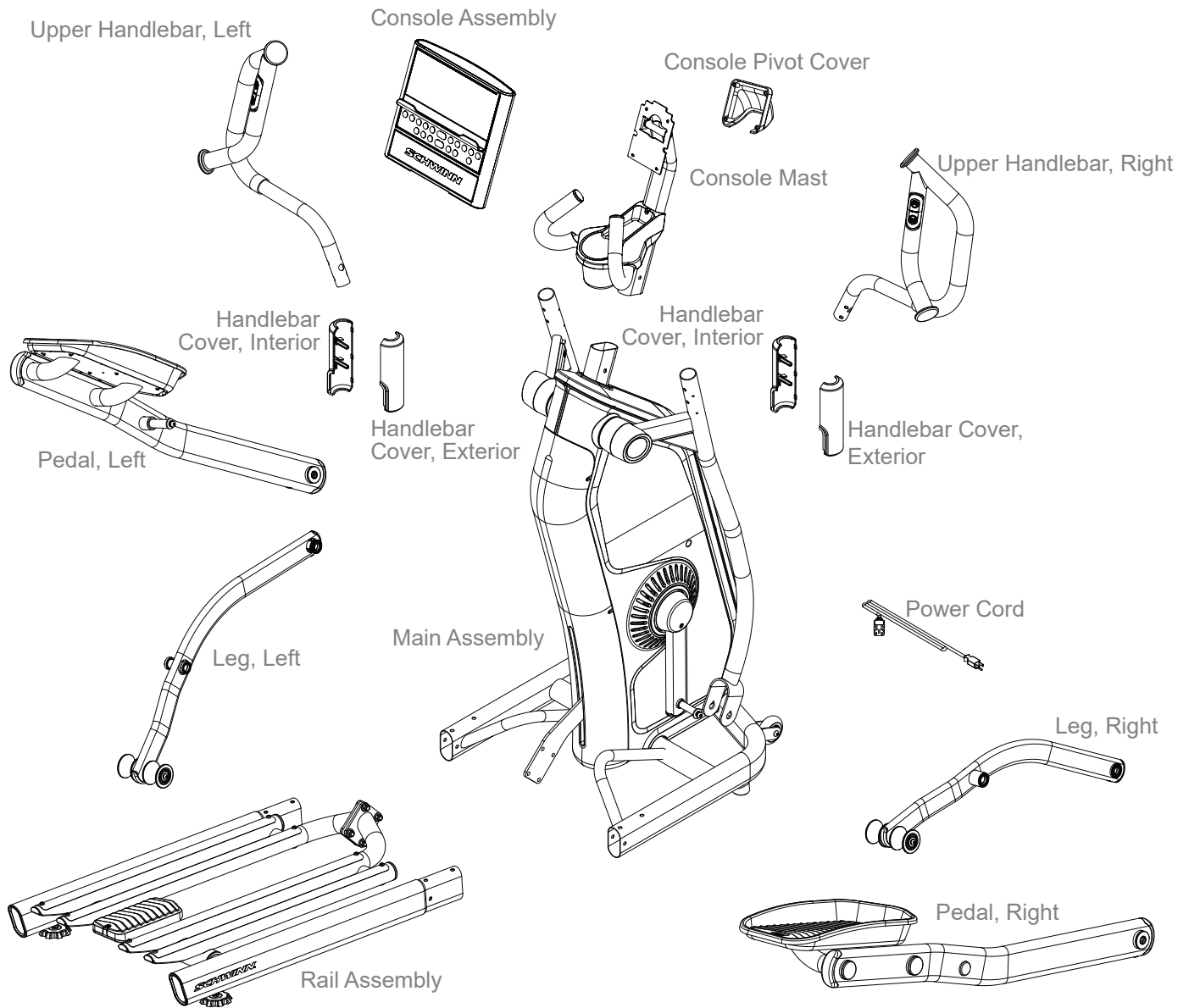

Maintenance Parts - Main Assembly

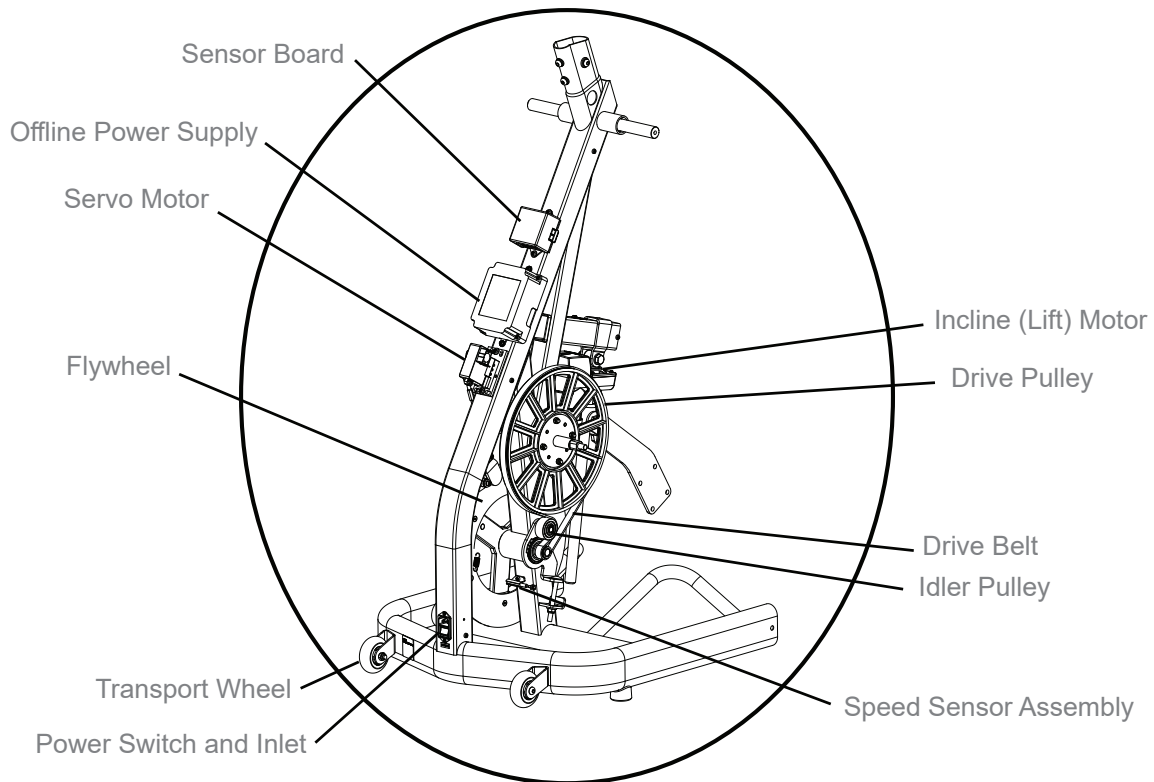
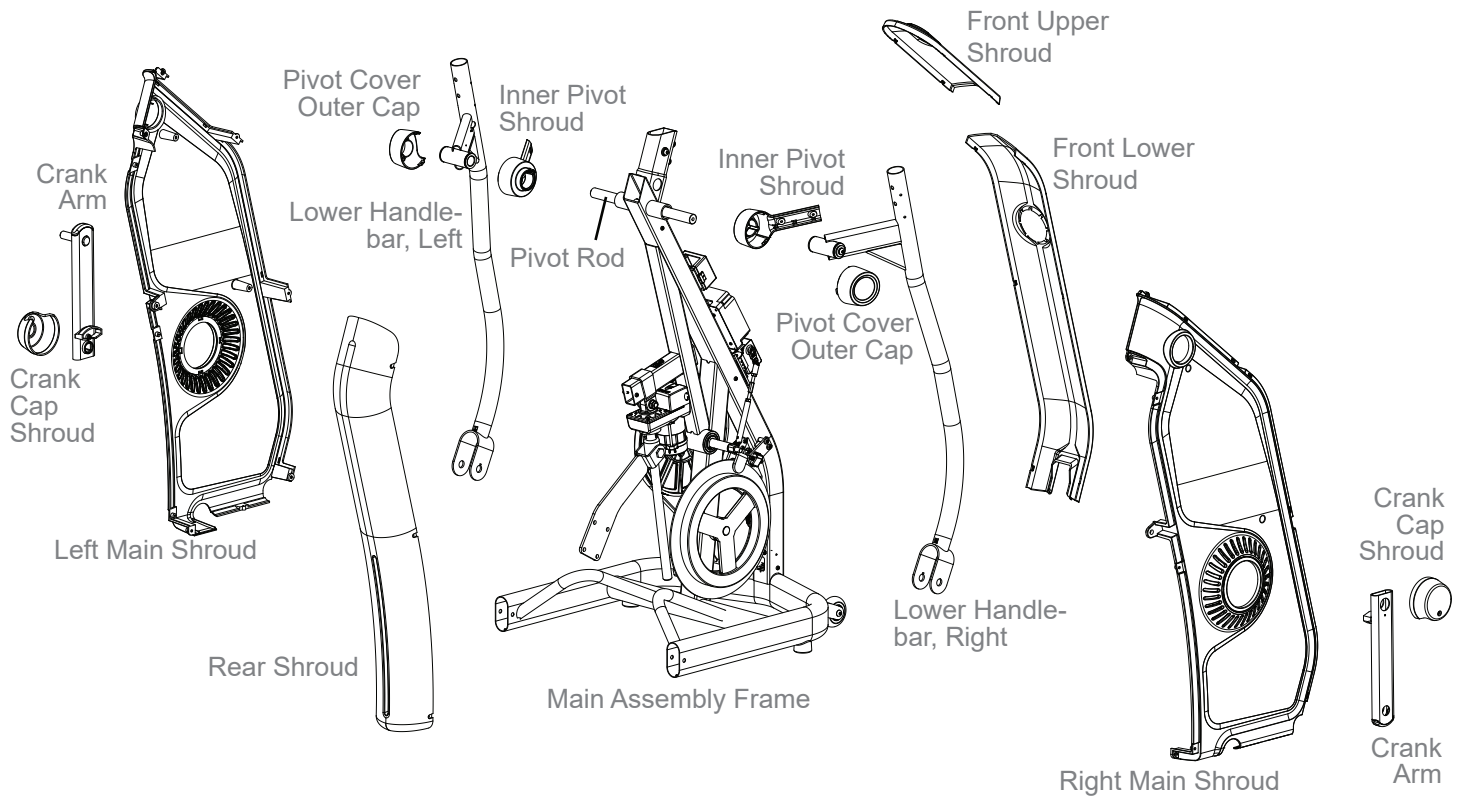

TROUBLESHOOTING

Condition/Problem	Things to Check	Solution
No display/partial display/ unit will not turn on	Check electrical (wall) outlet	Make sure unit is plugged into a functioning wall outlet.
	Check connection at front of unit	Connection should be secure and undamaged. Replace cord or power inlet if either are damaged.
	Check data cable integrity	All wires in cable should be intact. If any are visibly pinched or cut, replace cable.
	Check data cable connections/orientation	Be sure cables at base of mast and at back of console are connected securely and oriented properly. Small latch on connector should line up and snap into place.
	Check console display for damage	Check for visual sign that console display is cracked or otherwise damaged. Replace Console if damaged.
	Console Display	If Console only has partial display and all connections are fine, replace the Console.
Console display shows "0 Base Hub Comm Error" error code	Check data cable integrity	All wires in cable should be intact. If any are visibly pinched or cut, replace cable.
	Check data cable connections/orientation	Be sure cables at base of mast and at back of console are connected securely and oriented properly. Small latch on connector should line up and snap into place.
	Check console display for damage	Check for visual sign that console display is cracked or otherwise damaged. Replace Console if damaged.
		If the above steps do not resolve the problem, contact Customer Service (if inside US/Canada) or your local distributor (if outside US/Canada).
Console display shows "3 Stuck Button Error" error code	Check console keypad	Check for stuck buttons on the Console keypad. Replace Console if damaged.
		Be sure there is no object resting on one of the buttons depressing it. If issue persists, replace console.
Console display shows "5 NVRAM Error" error code	Console	Indicates problem with flash memory on Console. Contact Customer Service (if inside US/Canada) or your local distributor (if outside US/Canada).
Unit operates but Bluetooth® Heart Rate (HR) not displayed	HR monitor (not provided)	Follow the troubleshooting instructions provided with the device.
	HR monitor batteries	If monitor has replaceable batteries, install new batteries.
	Interference	Try moving unit away from sources of interference (TV, Microwave, etc).
	On/Off LED button	During a workout, only push the On/Off LED button once to activate the armband.
	Replace HR device	If interference is eliminated and HR does not function, replace HR device.
		If the above steps do not resolve the problem, contact Customer Service (if inside US/Canada) or your local distributor (if outside US/Canada).

Condition/Problem	Things to Check	Solution
No speed/RPM reading	Check data cable integrity	All wires in cable should be intact. If any are cut or pinched, replace cable.
	Check data cable connections/orientation	Be sure each cable is connected securely and oriented properly. Small latch on connector should line up and snap into place.
	Check magnet position (requires shroud removal)	Magnet should be in place on pulley.
	Check Speed Sensor (requires shroud removal)	Speed sensor should be aligned with magnet and connected to data cable. Realign sensor if necessary. Replace if there is any damage to the sensor or the connecting wire.
Resistance does not change (machine turns on and operates)	Check data cable integrity	All wires in cable should be intact. If any are visibly pinched or cut, replace cable.
	Check data cable connections/orientation	Be sure cable is connected securely and oriented properly. Small latch on connector should line up and snap into place.
	Check Servo Motor (requires shroud removal)	Replace Servo Motor if not functioning properly.
	Check Console display for damage	Check for visual sign that console display is cracked or otherwise damaged. Replace Console if damaged.
	Resistance handlebar connection	Be sure cable from right Upper Handlebar and cables to Console are secure and undamaged.
		If the above steps do not resolve the problem, contact Customer Service (if inside US/Canada) or your local distributor (if outside US/Canada).
Incline does not adjust (machine turns on and operates)	Check data cable connections/orientation	Be sure cable is connected securely and oriented properly. Small latch on connector should line up and snap into place.
	Check Console display for damage	Check for visual sign that console display is cracked or otherwise damaged. Replace Console if damaged.
	Incline handlebar connection	Be sure cable from left Upper Handlebar and cables to Console are secure and undamaged.
	Incline Adjuster Assembly (requires shroud removal)	Be sure Incline Adjuster Assembly is attached to Incline Motor drive screw.
	Console display shows "Incline Cooling" error code	Additional incline adjustments are disabled for a few minutes to protect the motor from over heating. Allow the lift motor to cool, and then resume your workout.
		If the above steps do not resolve the problem, contact Customer Service (if inside US/Canada) or your local distributor (if outside US/Canada).

Condition/Problem	Things to Check	Solution
Console shuts off (enters sleep mode) while in use	Check electrical (wall) outlet	Make sure unit is plugged into a functioning wall outlet.
	Check connection at front of unit	Connection should be secure and undamaged. Replace cord or power inlet if either are damaged.
	Check data cable integrity	All wires in the cable should be intact. If any are cut or pinched, replace cable.
	Check data cable connections/orientation	Be sure cable is connected securely and oriented properly. Small latch on connector should line up and snap into place.
	Reset machine	Unplug unit from electrical outlet for 3 minutes. Reconnect to outlet.
	Check magnet position (requires shroud removal)	Magnet should be in place on pulley.
	Check Speed Sensor (requires shroud removal)	Speed sensor should be aligned with magnet and connected to data cable. Realign sensor if necessary. Replace if there is any damage to the sensor or the connecting wire.
Unit rocks/does not sit level	Check leveler adjustment	Adjust levelers until machine is level.
	Check surface under unit	Adjustment may not be able to compensate for extremely uneven surfaces. Move machine to level area.
Pedals loose/unit difficult to operate	Hardware	Tightly secure all hardware on the Pedals, Legs and Handlebar Arms.
Drive train click/tick noise once per full crank revolution	Check crank/pulley assembly	Disconnect left and right foot assemblies and rotate crank. If sound persists, replace crank/pulley assembly. If sound does not come from rotating crank, check foot assemblies and upper/lower handlebars.
	Check Pedal, Leg and Handlebar assemblies	Manually move Pedal, Leg, and Handlebar assemblies to isolate sound. Replace part making sound.
	Check for loose hardware	Tightly secure all hardware on the Rail Assembly and the base of the Console Mast.
Knocking sound during machine operation	Check hardware at junction between Lower Handlebar Arm and Pedal	Make sure that the alignment tab on the Pivot Sleeve goes into the slot in the hole. Be sure the Pivot Sleeve extends through the opposite hole in the joint cover.
Squeaking noise that appears a few minutes into a workout and normally will get progressively worse as the workout continues	Bolts that connect the Lower Handlebars to the axle running through the Main Assembly	Loosen pivot rod bolts slightly until noise goes away. White lithium grease can also be applied for a temporary fix. Contact Customer Service (if inside US/Canada) or your local distributor (if outside US/Canada).
	Roller squeaking on rail	Apply silicone lubricant to a dry cloth and wipe the rails to eliminate roller noise.
Console continuously cycles through program screens	Console is in demonstration mode	Press and hold the Schwinn™ logo button for 3 seconds. The setting will take effect after the next time the machine goes into Sleep Mode.

CONSOLE SETUP MODE

The Console Setup Mode allows you to set units of measurement to either Imperial or metric, adjust screen brightness, view maintenance statistics (such as Run Time hours and software version – for service technician use only), or reset the Console.

1. Push the Programs button and hold for 3 seconds while in the Power-Up Mode to go into the Console Setup Mode (System Menu).
Note: Push the Pause/Stop button to exit the System Menu and return to the Power-Up Mode screen.
2. The Console display shows the System Units prompt with the current setting. The default setting is Imperial English units. Push the Resistance Increase/Decrease buttons to change between Imperial (MI/LB) and metric (KM/KG).
Note: If the units change when there is data in User Statistics, the statistics convert to the new units.
3. Push the Programs button to set the selection and continue to the next menu option.
Note: To save the selection and exit the System Menu, push the Start button. To exit without saving, push the Pause/Stop button.
4. The Console display shows the Screen Brightness prompt with the current setting. The 5 levels of brightness are: 5 (100%), 4 (default, 95%), 3 (90%), 2 (85%), 1 (80%). The display shows the brightness of the selected level. Push the Resistance Increase/Decrease buttons to move to the desired level.
5. Push the Programs button to set the selection and continue to the next menu option.
6. The Console display shows the Disconnect Bluetooth prompt. The default option is NO. The YES option will disconnect all Bluetooth® devices. Push the Resistance Increase/Decrease buttons to change between options (YES/NO).
7. Push the Programs button to set the selection and continue to the next menu option.
8. The Console display shows the Auto Connect HR (Heart Rate) prompt. The default option is YES. Push the Resistance Increase/Decrease buttons to change between options (YES/NO).
9. Push the Programs button to set the selection and continue to the next menu option.
10. The Console display shows the Hardware Variant & Console Firmware Version.
11. Push the Programs button to continue to the next menu option.
12. The Console display shows the Base Serial Number.
13. Push the Programs button to continue to the next menu option.
14. The Console display shows the Hardware Variant (machine type).
15. Push the Programs button to set the selection and continue to the next menu option.
16. The Console display shows the Run Time hours (total number of hours of workout time).
17. Push the Programs button to continue to the next menu option.
18. The Console display shows the BLE Version.
19. Push the Programs button to continue to the next menu option.
20. The Console display shows the BTC Version.
21. Push the Programs button to continue to the next menu option.
22. The Console display shows the SENSOR Version.
23. Push the Programs button to continue to the next menu option.
24. The Console display shows the Error Log prompt (for service technician use only). Push the Resistance Decrease button to move through the logged errors. At the end of the logged errors, the Console display shows the Clear Errors prompt (for service technician use only). To clear the errors, push the Start button.
25. Push the Programs button to continue to the next menu option.

26. The Console display shows the Reset Console prompt. The default option is NO. Push the Pause/Stop button to exit without starting Reset.

Note: The YES option will reset the System Units, Screen Brightness and Demo Mode to default settings. It does not reset the Run Time Hours.

Push the Resistance Increase/Decrease buttons to change between options (YES/NO).

Push the Start button to set the selection and exit the System Menu.

27. The Console will display the Power-Up Mode screen.

ELECTRICAL WIRING

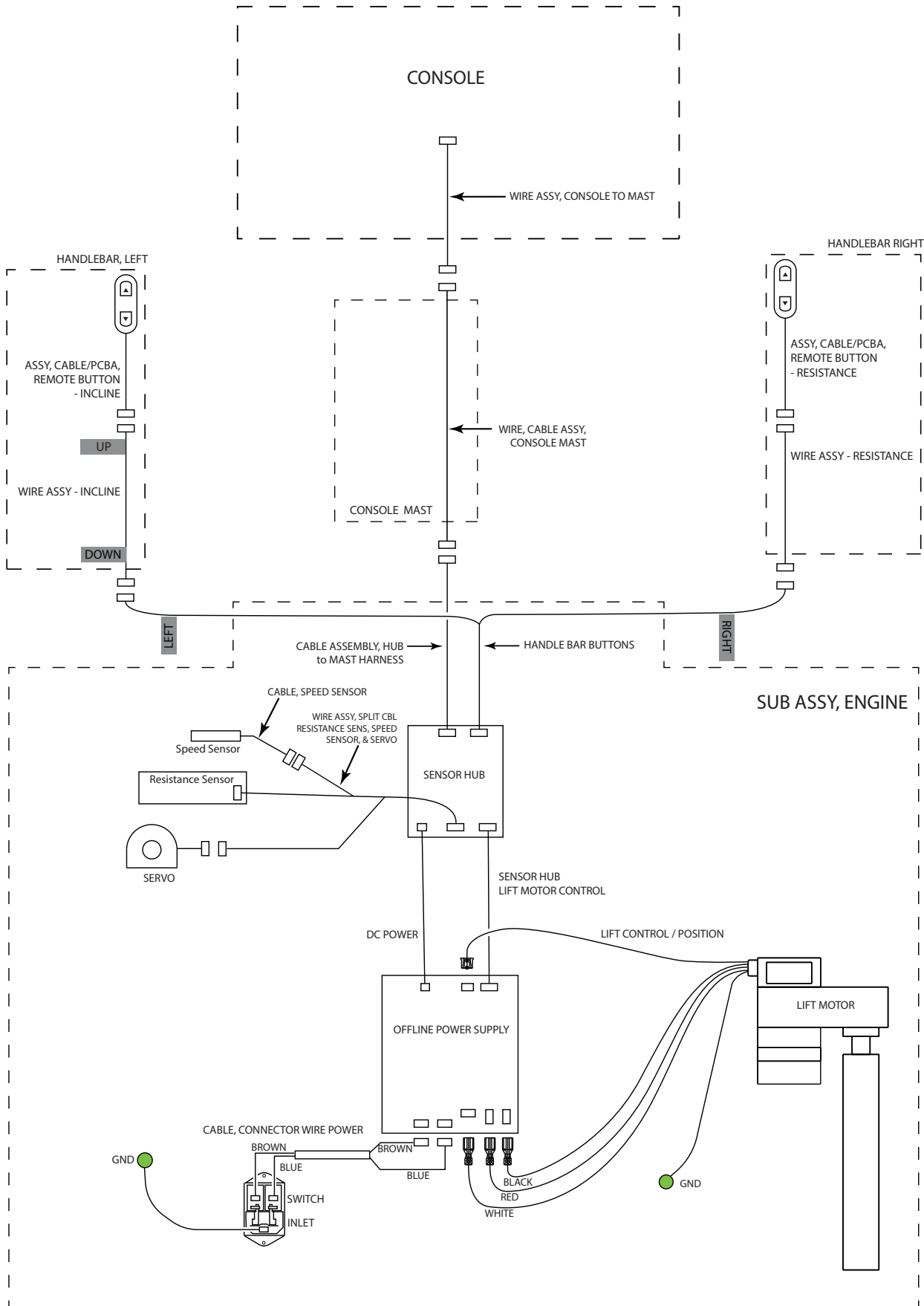

REPLACEMENT PROCEDURE SKILL LEVEL

Level I :	Low - very little mechanical knowledge or exposure.
Level II :	Intermediate - some experience with mechanical procedures
Level III :	Advanced - knowledgeable about mechanical procedures

⚠ DANGER To reduce the risk of electrical shock or unsupervised usage of the equipment, always unplug the power cord from the wall outlet and wait 5 minutes before cleaning, maintaining or repairing this machine. Place the power cord in a secure location.

⚠ When disposing of old parts, obey the applicable local and provincial requirements.

NOTICE: This document provides instructions for the calibration of the Incline on the Schwinn™ 490 / 590e Ellipticals.

Note: If the calibration process fails because of a time out, run the procedure again.

If you need assistance, please contact Customer Service (if purchased in US/Canada) or your local distributor (if purchased outside US/Canada). To find your local distributor, go to: www.nautilusinternational.com

 **This icon means a potentially hazardous situation which, if not avoided, could result in death or serious injury. Read and understand all Warnings on this machine.**

Nautilus, Inc., www.nautilus.com, 5415 Centerpoint Parkway, Groveport, OH 43125 U.S.A. - Customer Service: North America (800) 605-3369, csnls@nautilus.com | outside U.S. www.nautilusinternational.com | Printed in China | © 2023 Nautilus, Inc. | Schwinn and the Schwinn logo are trademarks owned or licensed by Nautilus, Inc., registered or otherwise protected by common law in the United States and other nations. | **ORIGINAL DOCUMENT - ENGLISH VERSION ONLY**

Important Safety Instructions - Before servicing or using this equipment, obey the following warnings:

 **This icon means a potentially hazardous situation which, if not avoided, could result in death or serious injury. Read and understand all Warnings on this machine.**

 **DANGER** **To reduce the risk of electrical shock or unsupervised usage of the equipment, always unplug the power cord from the wall outlet and wait 5 minutes before cleaning, maintaining or repairing this machine. Place the power cord in a secure location.**

- Read and understand the Part Replacement Procedure before working on the machine. Failure to obey the instructions and safety warnings could cause injury to the service technician or bystanders.
- Keep bystanders and children away from the product being serviced at all times.
- Disconnect all power to the machine before you service it.
- Make sure that the repair is done in an appropriate work space away from foot traffic and exposure to bystanders.
- Some components of the equipment can be heavy or awkward. Enlist the service of a second person when you do maintenance steps involving these components. Do not try to do heavy or awkward steps on your own.
- Use only replacement parts and hardware that are supplied or approved by Nautilus. Failure to use Nautilus-approved replacement parts can adversely affect the safety and functionality of the equipment creating a risk to users and will void the warranty.
- Be sure that all warning stickers and instructional placards applied to the product stay present and in good condition when doing maintenance or replacing components. If at any time the Warning labels become loose, unreadable or dislodged, replace the labels. If purchased in US/Canada, contact Customer Service for replacement labels. If purchased outside US/Canada, contact your local distributor for them.
- Do not try to change the design or functionality of the machine being serviced as this can adversely affect user safety.
- Do not use the machine until all shrouds, instructions, warning labels and correct functionality have been verified and tested for correct performance.

• SAVE THESE INSTRUCTIONS

Note: During the calibration process no one should be pedaling the machine or standing on the pedals.

1. Plug the power cord into the machine and wall outlet, and flip the power switch to on.

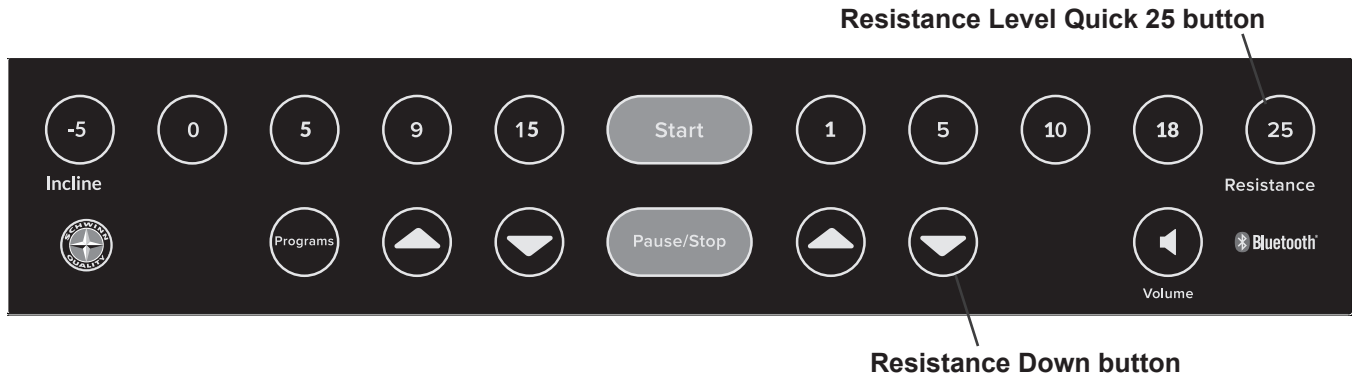

2. Push the Programs button and hold for 3 seconds while in the Power-Up Mode to go into the Console Setup Mode (System Menu).

Note: To exit the System Menu and return to the Power-Up Mode screen, push the Pause/Stop button.

3. The Console display shows the System Units prompt with the current setting. Tap the Programs button 4 times to advance through the System Menu.

4. The Console display shows the Hardware Variant & Console Firmware Version. The sample screen shows the format (values may be different).

Push and hold for 3 seconds the Resistance Level Quick 25 button to go to the Manufacturing Test Menu.

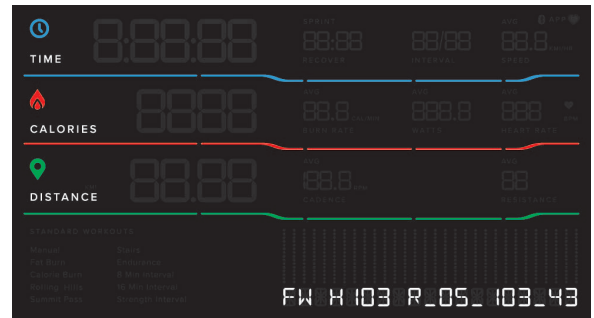

5. The Console display shows the START TEST SUITE menu option. Push the Resistance Decrease (▼) button 3 times to advance to the CAL_INCLINE option.

If the Start button was pushed instead of the Resistance Decrease (▼) button twice, turn the Power Switch to OFF and return to Step 1.

If the Resistance Decrease (▼) button was pushed more than 3 times going past the CAL_INCLINE option, push the Resistance Increase (▲) button to return to the CAL_INCLINE option.



6. The Console display shows the CAL_INCLINE option. Push the Start button.

Note: If the Pause/Stop button is pushed part way through the calibration (exit), the new calibration is not saved.



7. The console will display changing text and numbers for approximately 30 seconds as the incline motor fully raises the Pedals, then fully lowers the Pedals, and then brings the Pedals to the level or “0” setting.

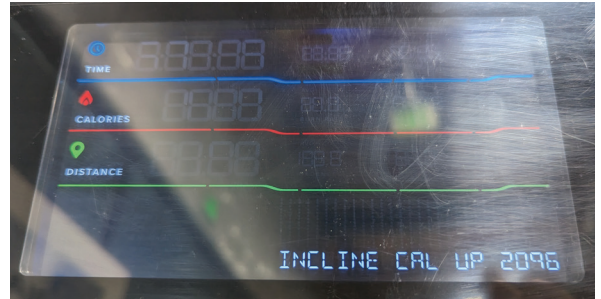

8. The console display will change to “CNFRM AT LVL 0 24XX”.

Note: The 0 incline level can be trimmed here for near perfect level position by using the Incline Increase (▲) and Incline Decrease (▼) buttons. If a finer level of adjustment is needed, use the Incline Level Quick 9 button to slightly increase, or the Incline Level Quick 15 button to slightly decrease.



9. Push the Start button to confirm and save the incline calibration values. The display will momentarily change to “SAVE ZERO LVL:24XX”, then display “CAL_INCLINE”. Calibration is complete.

Note: Pushing the Pause/Stop button will abort the calibration process, with the new calibration values not being saved, and the last saved calibration values being restored.

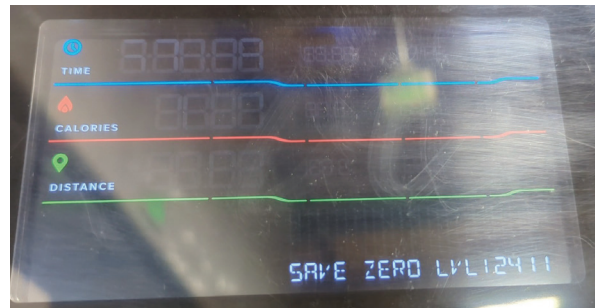

10. Power off the machine.

11. Power on the machine. After the Power-Up/Welcome screen appears, use the Incline Level Quick keys 15 and -5 to confirm that the incline moves properly between incline level -5 and 15.

12. Final Inspection

Inspect your machine to ensure that all hardware is tight and components are properly assembled.



Do not use until the machine has been fully assembled and inspected for correct performance in accordance with the Owner’s Manual.

NOTICE: This document provides instructions for the calibration of the Resistance on the Schwinn™ 490 / 590e Ellipticals.

Note: If the calibration process fails because of a time out, run the procedure again.

If you need assistance, please contact Customer Service (if purchased in US/Canada) or your local distributor (if purchased outside US/Canada). To find your local distributor, go to: www.nautilusinternational.com

 **This icon means a potentially hazardous situation which, if not avoided, could result in death or serious injury. Read and understand all Warnings on this machine.**

Nautilus, Inc., www.nautilus.com, 5415 Centerpoint Parkway, Groveport, OH 43125 U.S.A. - Customer Service: North America (800) 605-3369, csnls@nautilus.com | outside U.S. www.nautilusinternational.com | Printed in China | © 2023 Nautilus, Inc. | Schwinn and the Schwinn logo are trademarks owned or licensed by Nautilus, Inc., registered or otherwise protected by common law in the United States and other nations. | **ORIGINAL DOCUMENT - ENGLISH VERSION ONLY**

Important Safety Instructions - Before servicing or using this equipment, obey the following warnings:

 **This icon means a potentially hazardous situation which, if not avoided, could result in death or serious injury. Read and understand all Warnings on this machine.**

 **DANGER** **To reduce the risk of electrical shock or unsupervised usage of the equipment, always unplug the power cord from the wall outlet and wait 5 minutes before cleaning, maintaining or repairing this machine. Place the power cord in a secure location.**

- Read and understand the Part Replacement Procedure before working on the machine. Failure to obey the instructions and safety warnings could cause injury to the service technician or bystanders.
- Keep bystanders and children away from the product being serviced at all times.
- Disconnect all power to the machine before you service it.
- Make sure that the repair is done in an appropriate work space away from foot traffic and exposure to bystanders.
- Some components of the equipment can be heavy or awkward. Enlist the service of a second person when you do maintenance steps involving these components. Do not try to do heavy or awkward steps on your own.
- Use only replacement parts and hardware that are supplied or approved by Nautilus. Failure to use Nautilus-approved replacement parts can adversely affect the safety and functionality of the equipment creating a risk to users and will void the warranty.
- Be sure that all warning stickers and instructional placards applied to the product stay present and in good condition when doing maintenance or replacing components. If at any time the Warning labels become loose, unreadable or dislodged, replace the labels. If purchased in US/Canada, contact Customer Service for replacement labels. If purchased outside US/Canada, contact your local distributor for them.
- Do not try to change the design or functionality of the machine being serviced as this can adversely affect user safety.
- Do not use the machine until all shrouds, instructions, warning labels and correct functionality have been verified and tested for correct performance.

• SAVE THESE INSTRUCTIONS

CAUTION

Do not use the Console Resistance Quick Keys to set resistance until the calibration process is complete and calibration saved.

Note: During the calibration process no one should be pedaling the machine. Standing on the pedals is okay during the calibration process.

1. Plug the power cord into the machine and wall outlet, and flip the power switch to on.

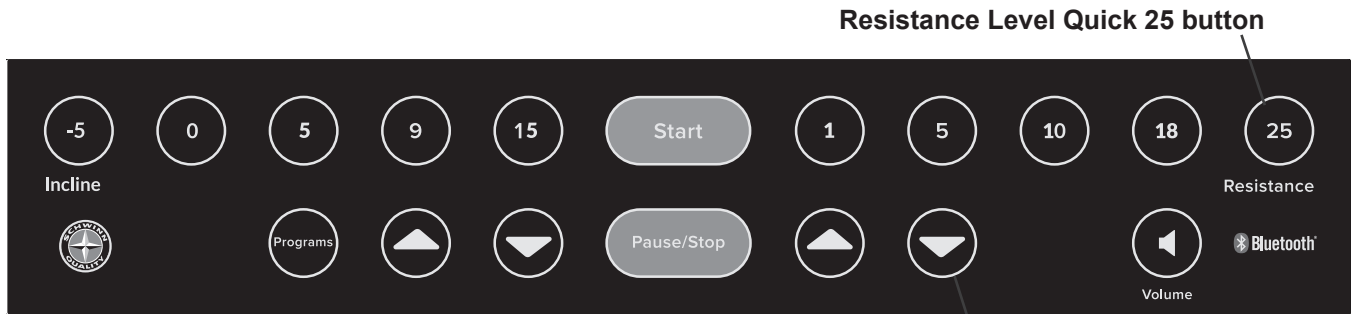

2. Push the Programs button and hold for 3 seconds while in the Power-Up Mode to go into the Console Setup Mode (System Menu).

Note: To exit the System Menu and return to the Power-Up Mode screen, push the Pause/Stop button.

3. The Console display shows the System Units prompt with the current setting. Tap the Programs button 4 times to advance through the System Menu.

4. The Console display shows the Hardware Variant & Console Firmware Version. The sample screen shows the format (values may be different).

Push and hold for 3 seconds the Resistance Level Quick 25 button to go to the Manufacturing Test Menu.

5. The Console display shows the START TEST SUITE menu option. Push the Resistance Down (▼) button 2 times to advance to the AUTO CAL_RESISTANCE (Automated Calibrate Resistance) option.

If the Start button was pushed instead of the Resistance Down (▼) button twice, turn the Power Switch to OFF and return to Step 1.

When the display shows “CALIBRATE RESISTANCE” do **NOT** push Start. This option is not used. Push the Resistance Down (▼) button one more time.

If the Resistance Down (▼) button was pushed more than 2 times going past the AUTO CAL_RESISTANCE option, push the Resistance Increase (▲) button to return to the AUTO CAL_RESISTANCE (Automated Calibrate Resistance) option.

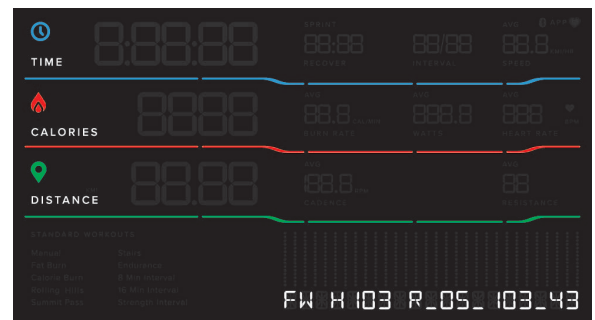

6. The Console display shows the AUTO CAL_RESISTANCE (Automated Calibrate Resistance) option. Push the Start button.

Note: If the Pause/Stop button is pushed part way through the calibration (exit), the new calibration is not saved.



7. The console will display changing text and numbers for approximately 30 seconds as the servo motor moves.



8. The console display will change to “CNFRM C4095 AGC XX”.



9. Push the Start button to confirm and save the resistance calibration values. The display will momentarily change to “SAVING CAL”, then display “AUTO CAL_RESISTANCE”. Calibration is complete.

Note: Pushing the Pause/Stop button will abort the calibration process, with the new calibration values not being saved, and the last saved calibration values being restored.

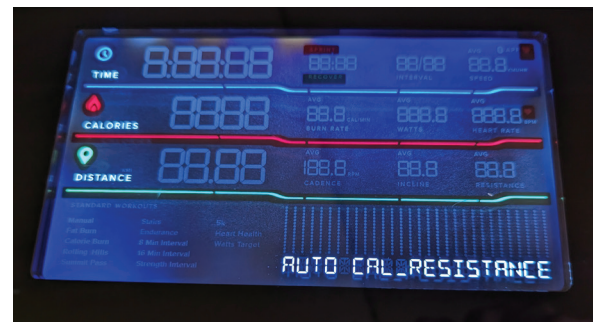

10. Power off the machine.

11. Power on the machine. After the Power-Up/Welcome screen appears, use the Resistance Level Quick keys 25 and 1 to confirm that the magnet caliper moves properly between resistance level 1 and 25.

12. Final Inspection

Inspect your machine to ensure that all hardware is tight and components are properly assembled.



Do not use until the machine has been fully assembled and inspected for correct performance in accordance with the Owner's Manual.

NOTICE: This document provides instructions for the replacement of the Cables on the Schwinn™ 490 / 590e Ellipticals.

If you need assistance, please contact Customer Service (if purchased in US/Canada) or your local distributor (if purchased outside US/Canada). To find your local distributor, go to: www.nautilusinternational.com

⚠ This icon means a potentially hazardous situation which, if not avoided, could result in death or serious injury. Read and understand all Warnings on this machine.

Nautilus, Inc., www.nautilus.com, 5415 Centerpoint Parkway, Groveport, OH 43125 U.S.A. - Customer Service: North America (800) 605-3369, csnls@nautilus.com | outside U.S. www.nautilusinternational.com | Printed in China | © 2023 Nautilus, Inc. | Schwinn and the Schwinn logo are trademarks owned or licensed by Nautilus, Inc., registered or otherwise protected by common law in the United States and other nations. | **ORIGINAL DOCUMENT - ENGLISH VERSION ONLY**

Important Safety Instructions - Before servicing or using this equipment, obey the following warnings:

⚠ This icon means a potentially hazardous situation which, if not avoided, could result in death or serious injury. Read and understand all Warnings on this machine.

⚠ DANGER To reduce the risk of electrical shock or unsupervised usage of the equipment, always unplug the power cord from the wall outlet and wait 5 minutes before cleaning, maintaining or repairing this machine. Place the power cord in a secure location.

- Read and understand the Part Replacement Procedure before working on the machine. Failure to obey the instructions and safety warnings could cause injury to the service technician or bystanders.
- Keep bystanders and children away from the product being serviced at all times.
- Disconnect all power to the machine before you service it.
- Make sure that the repair is done in an appropriate work space away from foot traffic and exposure to bystanders.
- Some components of the equipment can be heavy or awkward. Enlist the service of a second person when you do maintenance steps involving these components. Do not try to do heavy or awkward steps on your own.
- Use only replacement parts and hardware that are supplied or approved by Nautilus. Failure to use Nautilus-approved replacement parts can adversely affect the safety and functionality of the equipment creating a risk to users and will void the warranty.
- Be sure that all warning stickers and instructional placards applied to the product stay present and in good condition when doing maintenance or replacing components. If at any time the Warning labels become loose, unreadable or dislodged, replace the labels. If purchased in US/Canada, contact Customer Service for replacement labels. If purchased outside US/Canada, contact your local distributor for them.
- Do not try to change the design or functionality of the machine being serviced as this can adversely affect user safety.
- Do not use the machine until all shrouds, instructions, warning labels and correct functionality have been verified and tested for correct performance.

• SAVE THESE INSTRUCTIONS

Tools Required (not included)

4mm hex wrench
6mm hex wrench



Piece of string or wire, about 60 cm (24 inches) long

Standard screwdriver



Zip-Ties (Replacements)
Something to cut a Zip-Tie



⚠ DANGER

To reduce the risk of electrical shock or unsupervised usage of the equipment, always unplug the power cord from the wall outlet and wait 5 minutes before cleaning, maintaining or repairing this machine. Place the power cord in a secure location.

Note: Your machine may not match the images provided exactly.

1. Unplug the Power Cord from the wall outlet and machine.

2. Flex the edges of the Front Lower Shroud to disengage the 8 inside tabs from the Main Shrouds.

Note: It may be easier to pry up the edges of the Front Lower Shroud using a flathead screwdriver. To avoid damage to the surface of the Shrouds, we recommend putting a piece of cloth over the screwdriver blade.



Note: The Shrouds have been removed from some of the images to provide additional details.

3. Flex the sides of the Sensor Hub Cover to disengage the 2 side tabs (indicated by ovals), and remove it.



Note: Main Shrouds removed for clarity.

To replace the:

Offline Power Supply to Sensor Hub (DC Power) and/or Lift Motor Control Cable	Section 1	page 4
Split Cable (Servo, Speed and Resistance) Assembly	Section 2	page 6
Sensor Hub to Upper Handlebar Buttons (Resistance and Incline) Cable	Section 3	page 8
For Re-Assembly and Final Inspection	Section 4	page 13

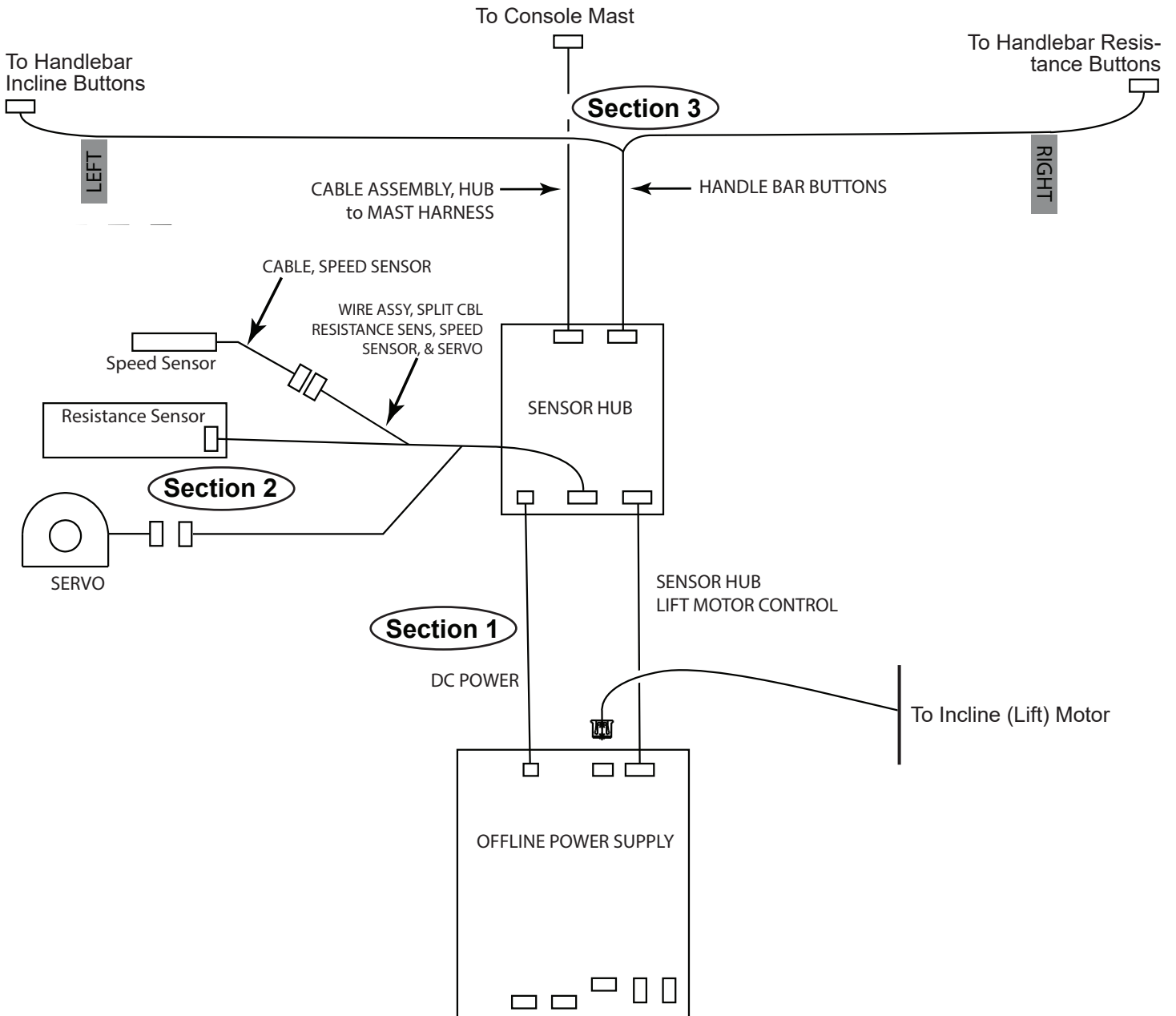

ELECTRICAL WIRING ROUTE DETAIL - Cables

Section 1 - Replacing the Offline Power Supply to Sensor Hub (DC Power) and/or Lift Motor Control Cables

 Make sure that power to the machine is disconnected before beginning this step.

1. Using a 4 mm hex wrench, remove the 4 screws (indicated by circles) that secure the Offline Power Supply Cover, and remove it.



Note: Main Shrouds removed for clarity.

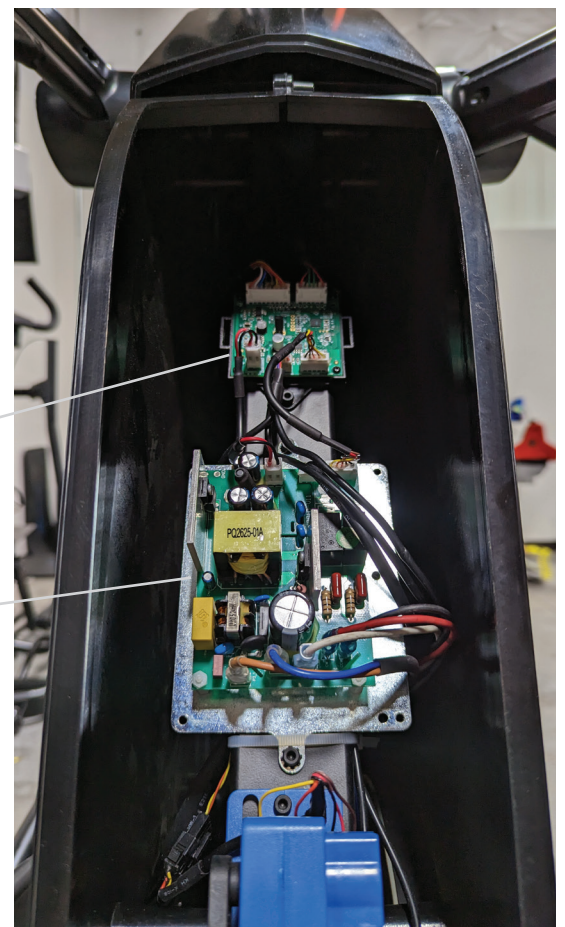
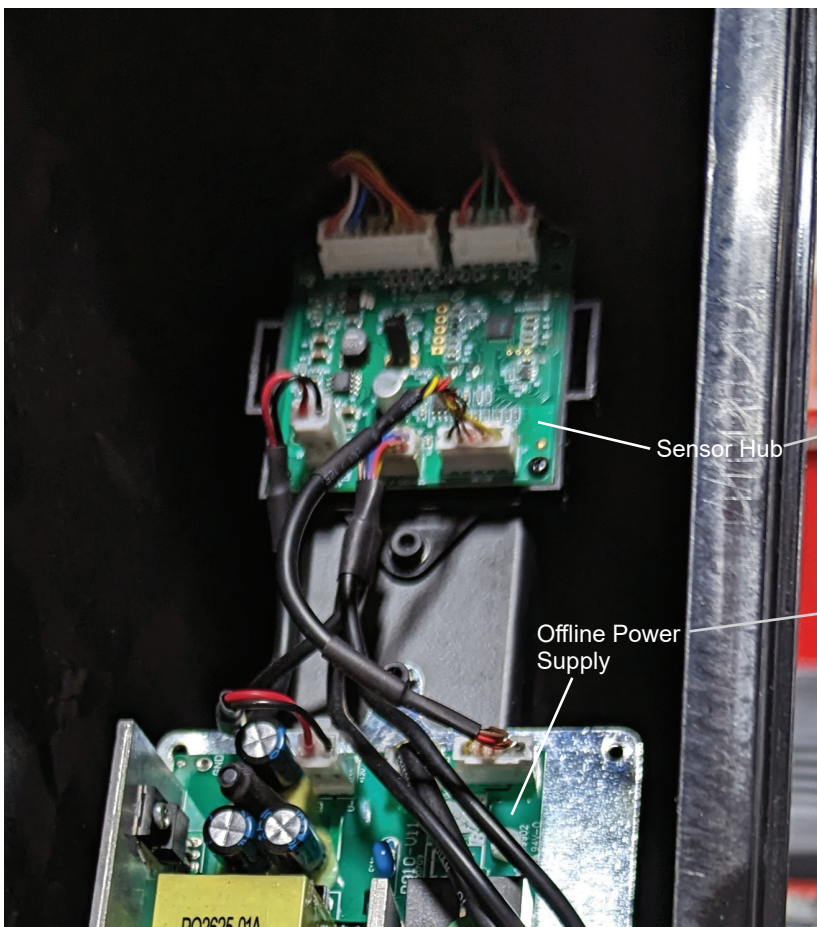

2. Remove the cable that is being replaced (Offline Power Supply to Sensor Hub (DC Power) Cable, or Lift Motor Control Cable) from the Sensor Hub and the Offline Power Supply.

Note: Be sure to note where all cables attach for re-assembly. Do not let the cables fall into the machine. If the Cable Connectors are secured by a small amount of glue, use a pair of small nose pliers to grab and remove the glue.

NOTICE: Do not cut or pinch the cables.

3. Connect the new cable to the Sensor Hub and the Offline Power Supply.

NOTICE: Do not cut or pinch the cables.

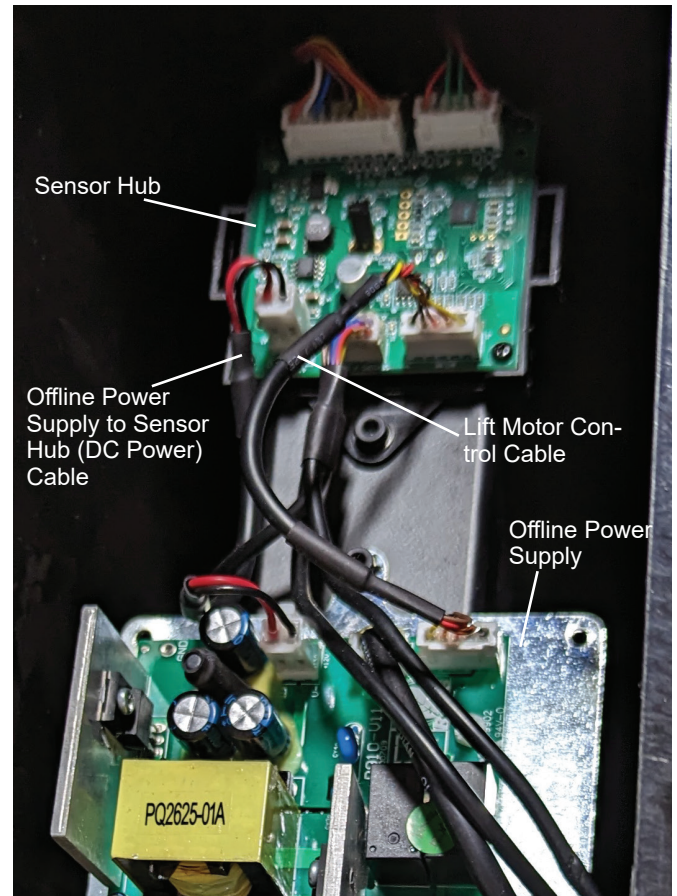

Section 2 - Replacing the Split Cable (Servo, Speed and Resistance) Assembly

Note: The Split Cable Assembly has a single connector on one end that connects to the Sensor Hub, with the other end having three cable connectors. The three connectors go to the Servo Motor, Speed Sensor, and Resistance Sensor.

Note: All Shrouds have been removed for clarity.

 **Make sure that power to the machine is disconnected before beginning this step.**

1. Carefully disconnect the old Split Cable Assembly Connector from the Sensor Hub.

NOTICE: Do not pinch or cut the cables.

2. Connect the single connector on the end of the new Split Cable Assembly to the Sensor Hub.

NOTICE: Do not pinch or cut the cables.

3. Carefully disconnect the Servo Motor Cable Connector.

NOTICE: Do not pinch or cut the cables.

4. Route the appropriate cable end of the new Split Cable Assembly to the Servo Motor Connector, and connect it.

NOTICE: Do not pinch or cut the cables.

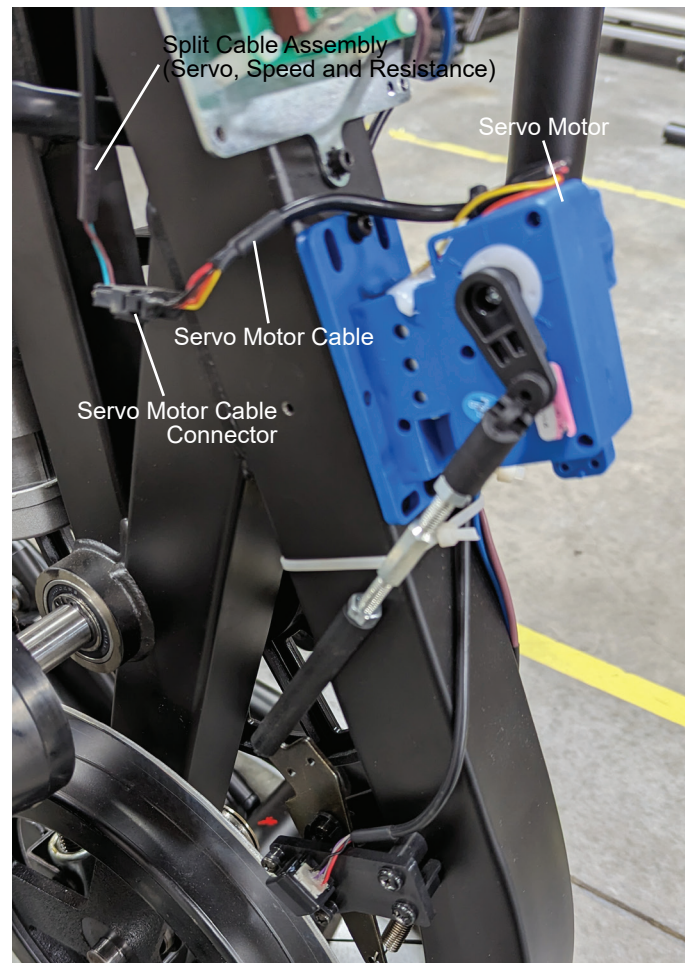
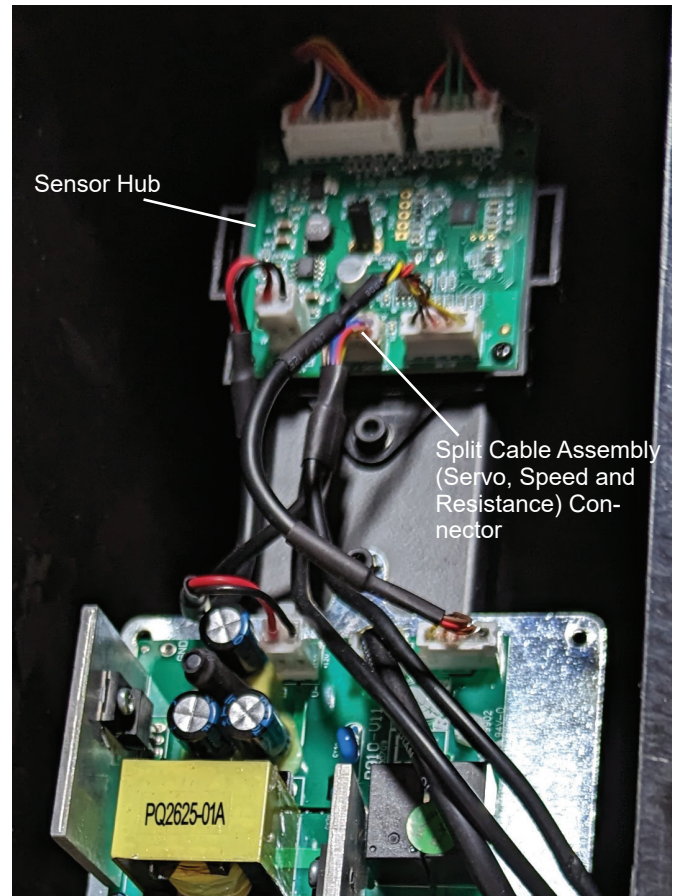

5. Disconnect the Speed Sensor Cable Connector.

6. Route the appropriate cable of the new Split Cable Assembly to the Speed Sensor Cable Connector, and connect it.

NOTICE: Do not pinch or cut the cables.

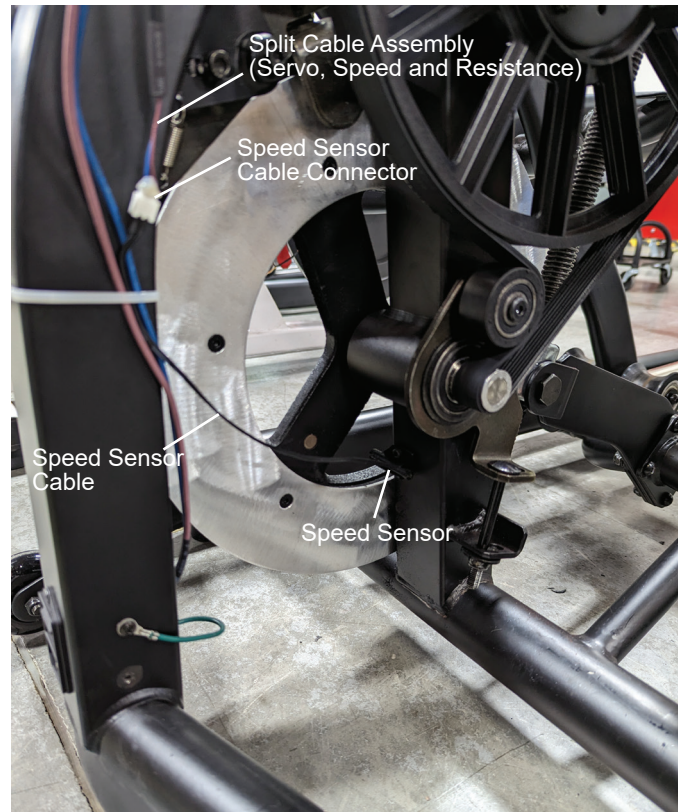

7. After noting how the Zip-Tie secures the Split Cable Assembly and other cables to the Frame, cut the Zip-Tie that secures them. Be sure not to damage or cut any cables.

8. Disconnect the Split Cable Assembly from the Resistance Sensor.

9. Route the remaining cable of the new Split Cable Assembly to the Resistance Sensor, and connect it.

NOTICE: Do not pinch or cut the cables.

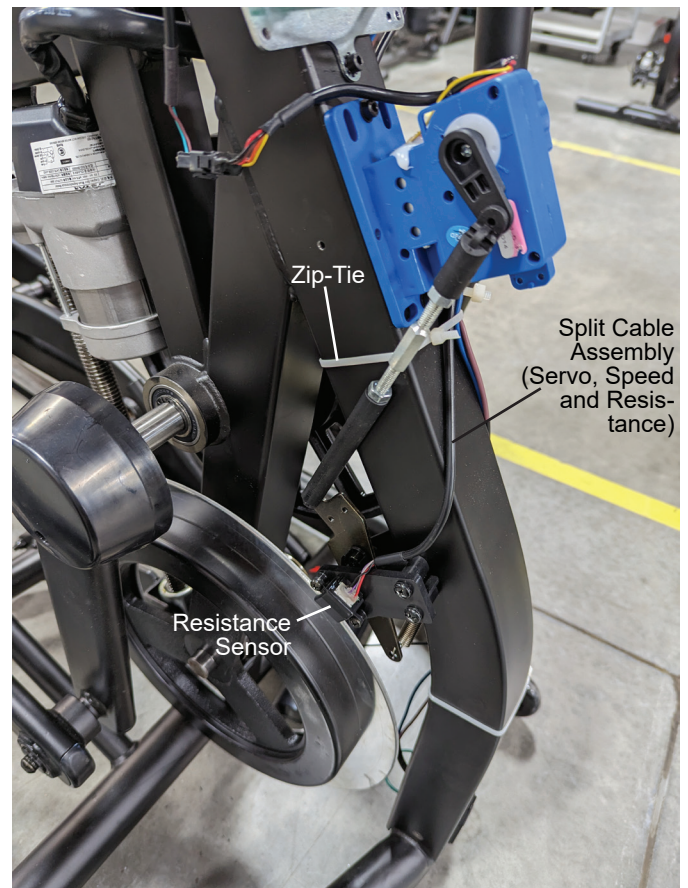

Section 3 - Replacing the Sensor Hub to Upper Handlebar Buttons (Resistance and Incline) Cable

Note: The Sensor Hub to Upper Handlebar Buttons Cable is a 'T' Cable, connecting the lower solo end to the Sensor Hub and the other two ends going to each of the Upper Handlebars. To replace this cable, both Handlebars will need to be removed.

1. Gently compress the Exterior Handlebar Cover to release it from the Interior Handlebar Cover. There are five tabs that snap to secure each Cover.



2. Using a #2 Phillips screwdriver, remove the two screws that attach the Interior Handlebar Cover to the Handlebars. Set the hardware safely aside for reassembly.



3. Using a 6mm hex wrench, remove the four screws that attach the Upper Handlebar to the Lower Handlebar.

4. Slightly pull the Upper Handlebar out of the Lower Handlebar, and disconnect the cables. Set the old Upper Handlebar and hardware safely aside.

NOTICE: Do not cut or pinch the cables. Do not let the cable fall down into the Lower Handlebar. This step may require two people.

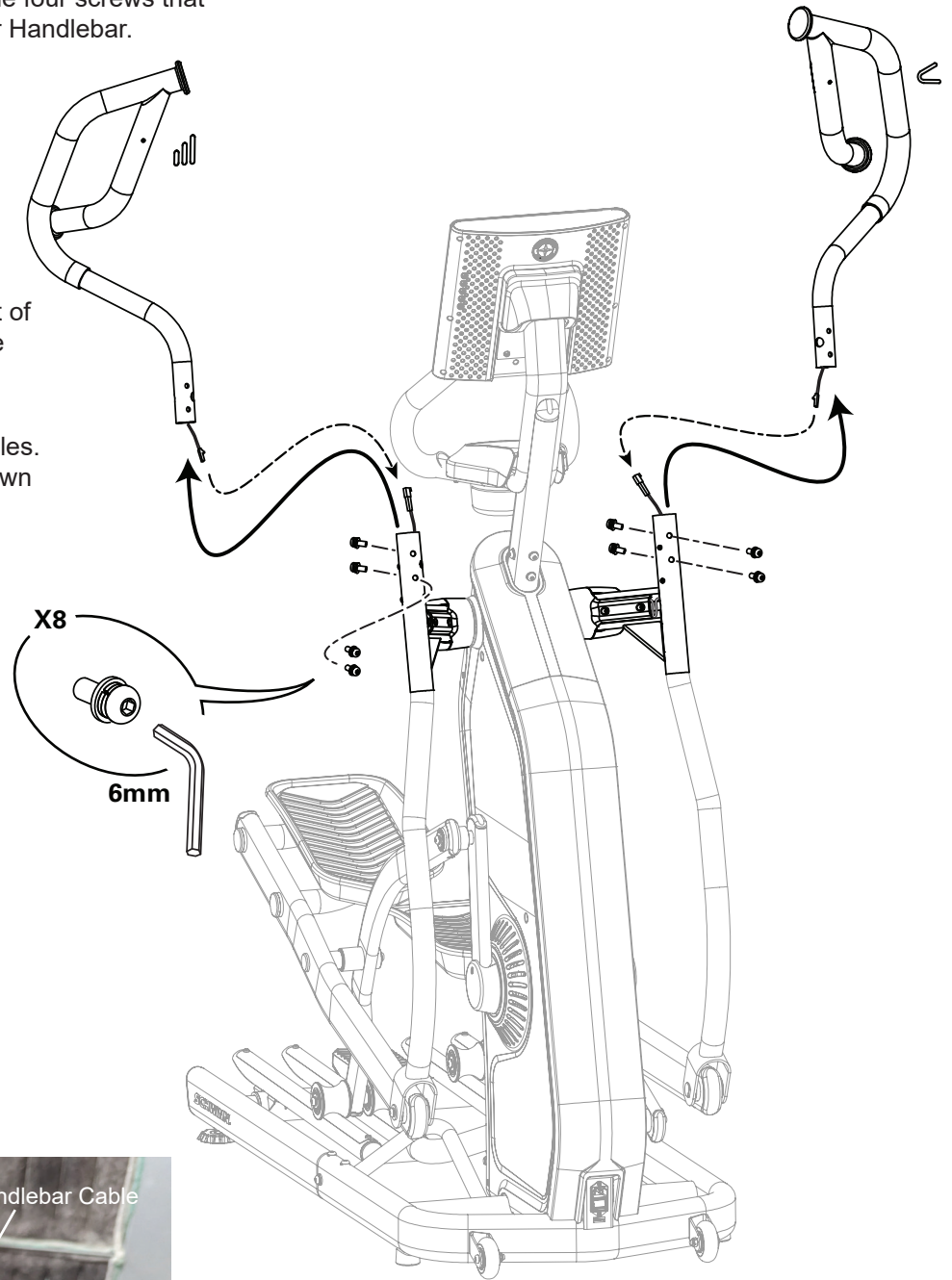

5. Gently compress the sides of the Pivot Cap to release it from the Inner Pivot Shroud.

6. Using a #2 Phillips screwdriver, remove the 2 screws (indicated by ovals) from the Inner Pivot Shroud.

7. Tie a 60 cm (24 inch) long piece of wire or string to the end of the Cable. This wire or string will be used to pull the new cable through and out of the Lower Handlebar.

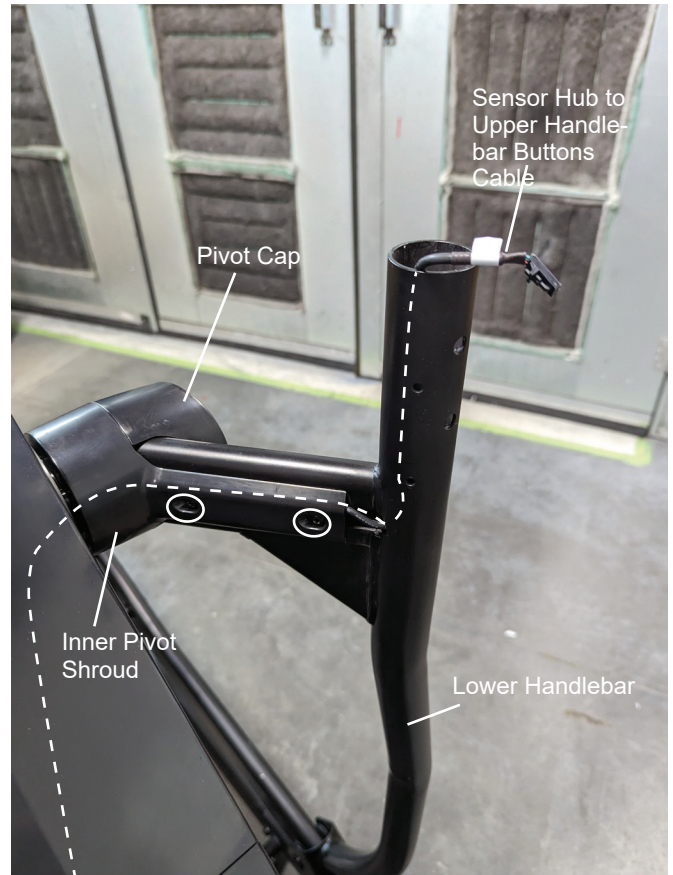

8. Using a 6mm hex wrench, remove the hardware (indicated by ovals) that attaches the Pedals and remove them.



Note: To assist with re-assembly, notice that the Pivot Pin is flush with the outside of the Lower Handlebar.



9. Using a 6mm hex wrench, remove the hardware (indicated by oval) that secures the Lower Handlebar.

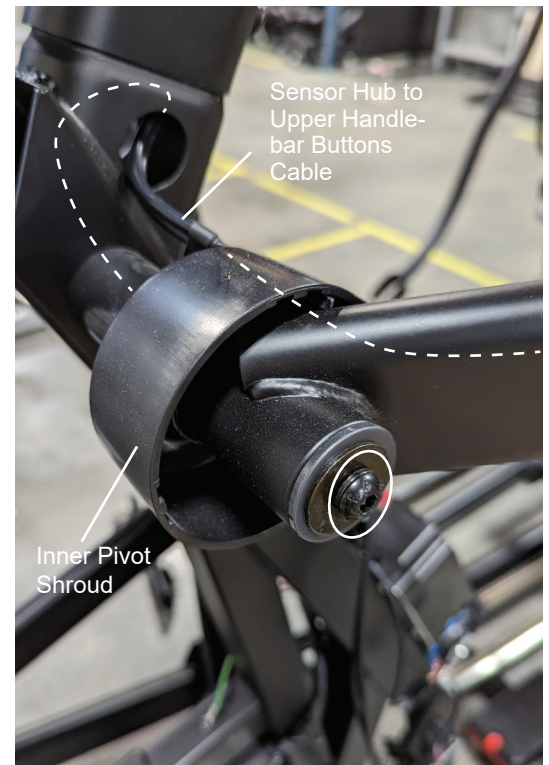

10. Slide the Lower Handlebar outward only about 1 inch (2.5 cm) from the machine.

11. Push the Inner Pivot Shroud toward the machine, off of the Lower Handlebar. This will release the Cable from the clips on the Inner Pivot Shroud.



12. With the wire or string still attached to the end of the Cable, pull the cable down into the machine from the Handlebar. Be sure not to pull the end of the wire or string into the Lower Handlebar.

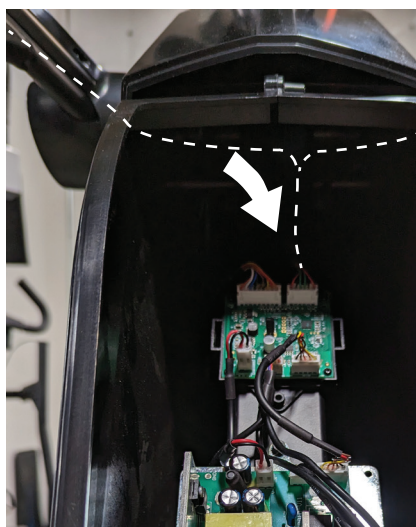

13. Remove the wire or string from the old cable, and secure it to the appropriate end of the new cable.

14. Route the new cable through the Lower Handlebar by gently pulling the wire or string from the Lower Handlebar.

NOTICE: Do not pinch or cut the cables.



15. Repeat the removal and routing of the cable on the other side of the machine from the other Lower Handlebar.

16. Remove the connector from the Sensor Hub, and attach the new cable connector.



Section 4 - Re-assembly and Final Inspection

1. Re-install all remaining parts that were removed in reverse order.

2. Final Inspection

Inspect your machine to ensure that all hardware is tight and components are properly assembled.



Do not use until the machine has been fully assembled and inspected for correct performance in accordance with the Owner's Manual.

NOTICE: This document provides instructions for the replacement of the Console on the Schwinn™ 490 / 590e Ellipticals.

If you need assistance, please contact Customer Service (if purchased in US/Canada) or your local distributor (if purchased outside US/Canada). To find your local distributor, go to: www.nautilusinternational.com

⚠ This icon means a potentially hazardous situation which, if not avoided, could result in death or serious injury. Read and understand all Warnings on this machine.

Nautilus, Inc., www.nautilus.com, 5415 Centerpoint Parkway, Groveport, OH 43125 U.S.A. - Customer Service: North America (800) 605-3369, csnls@nautilus.com | outside U.S. www.nautilusinternational.com | Printed in China | © 2023 Nautilus, Inc. | Schwinn and the Schwinn logo are trademarks owned or licensed by Nautilus, Inc., registered or otherwise protected by common law in the United States and other nations. | ORIGINAL DOCUMENT - ENGLISH VERSION ONLY

Important Safety Instructions - Before servicing or using this equipment, obey the following warnings:

⚠ This icon means a potentially hazardous situation which, if not avoided, could result in death or serious injury. Read and understand all Warnings on this machine.

⚠ DANGER To reduce the risk of electrical shock or unsupervised usage of the equipment, always unplug the power cord from the wall outlet and wait 5 minutes before cleaning, maintaining or repairing this machine. Place the power cord in a secure location.

- Read and understand the Part Replacement Procedure before working on the machine. Failure to obey the instructions and safety warnings could cause injury to the service technician or bystanders.
- Keep bystanders and children away from the product being serviced at all times.
- Disconnect all power to the machine before you service it.
- Make sure that the repair is done in an appropriate work space away from foot traffic and exposure to bystanders.
- Some components of the equipment can be heavy or awkward. Enlist the service of a second person when you do maintenance steps involving these components. Do not try to do heavy or awkward steps on your own.
- Use only replacement parts and hardware that are supplied or approved by Nautilus. Failure to use Nautilus-approved replacement parts can adversely affect the safety and functionality of the equipment creating a risk to users and will void the warranty.
- Be sure that all warning stickers and instructional placards applied to the product stay present and in good condition when doing maintenance or replacing components. If at any time the Warning labels become loose, unreadable or dislodged, replace the labels. If purchased in US/Canada, contact Customer Service for replacement labels. If purchased outside US/Canada, contact your local distributor for them.
- Do not try to change the design or functionality of the machine being serviced as this can adversely affect user safety.
- Do not use the machine until all shrouds, instructions, warning labels and correct functionality have been verified and tested for correct performance.

• SAVE THESE INSTRUCTIONS

Tools Required (not included)

#2 Phillips screwdriver



6mm hex wrench



⚠ DANGER

To reduce the risk of electrical shock or unsupervised usage of the equipment, always unplug the power cord from the wall outlet and wait 5 minutes before cleaning, maintaining or repairing this machine. Place the power cord in a secure location.

Note: Your machine may not match the images provided exactly. Upper Handlebars removed for clarity.

1. Unplug the AC Adapter from the wall outlet and machine.

2. Remove the Console Rear Cover from the back of the Console.

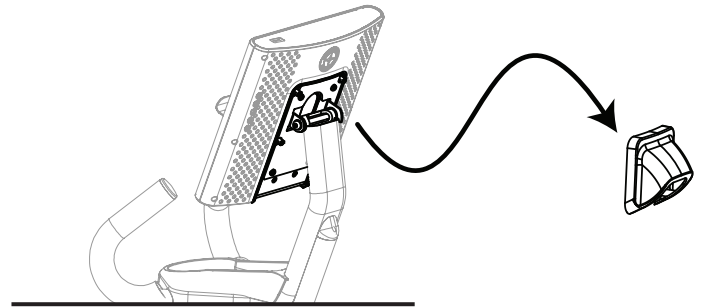

3. Remove the four screws that attach the Console to the Mast. Set the hardware safely aside for reassembly.

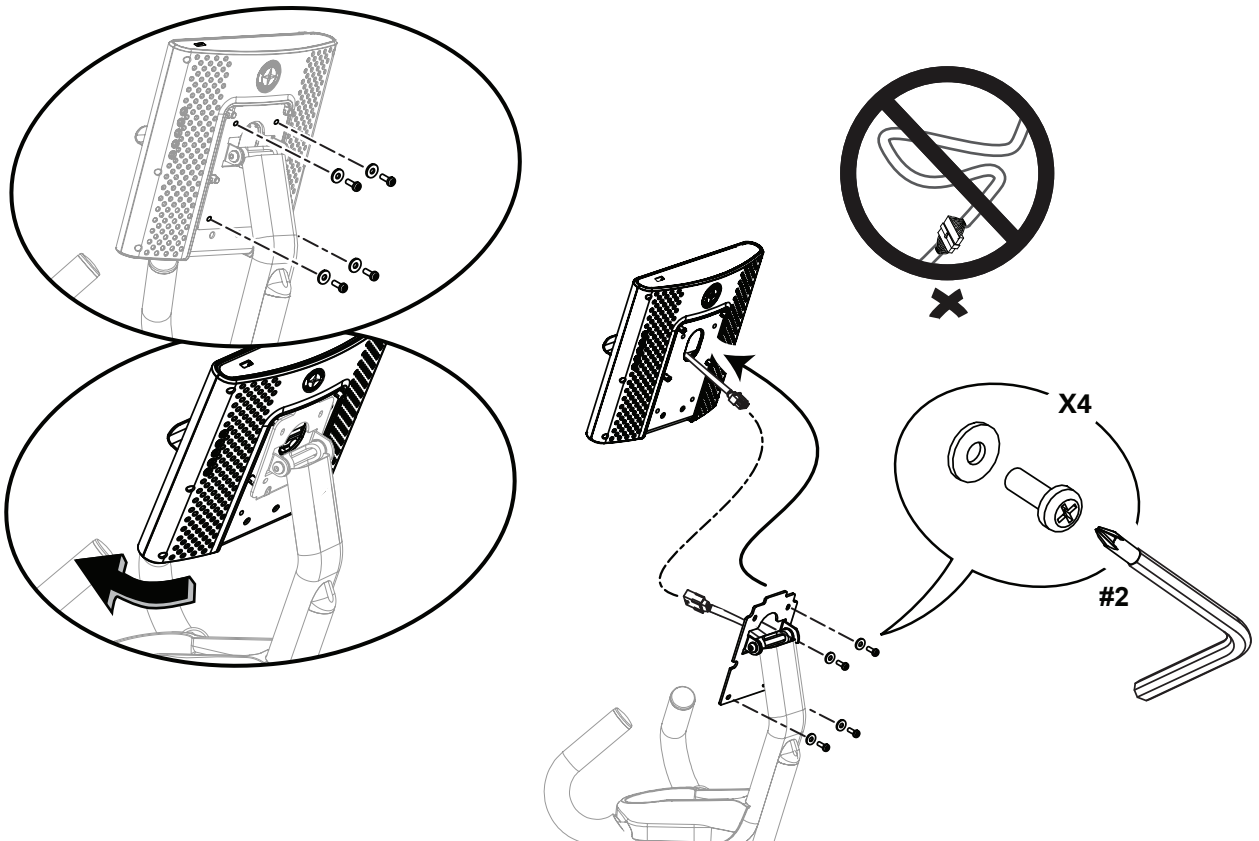

4. Disconnect the Data Cable from the back of the old Console. Carefully lift the old Console off the Mast, and set it safely aside.

Note: Do not let the cable fall down inside the Mast. This step may require two people.

NOTICE: Do not cut or pinch the cables.

5. Tilt the new Console to install the wide tab at the top of the Console Mount Bracket. Route the Console cable through the bracket.

6. Attach the Console to the Console Mount Bracket before connecting the cables. Start lower screws first, then tighten all screws. Connect the Console cable to the Console Mast cable. Align the clips on the cable connectors and make sure the connectors lock. Push the extra wire down into the Console Mast.

NOTICE: Do not cut or pinch the cables.

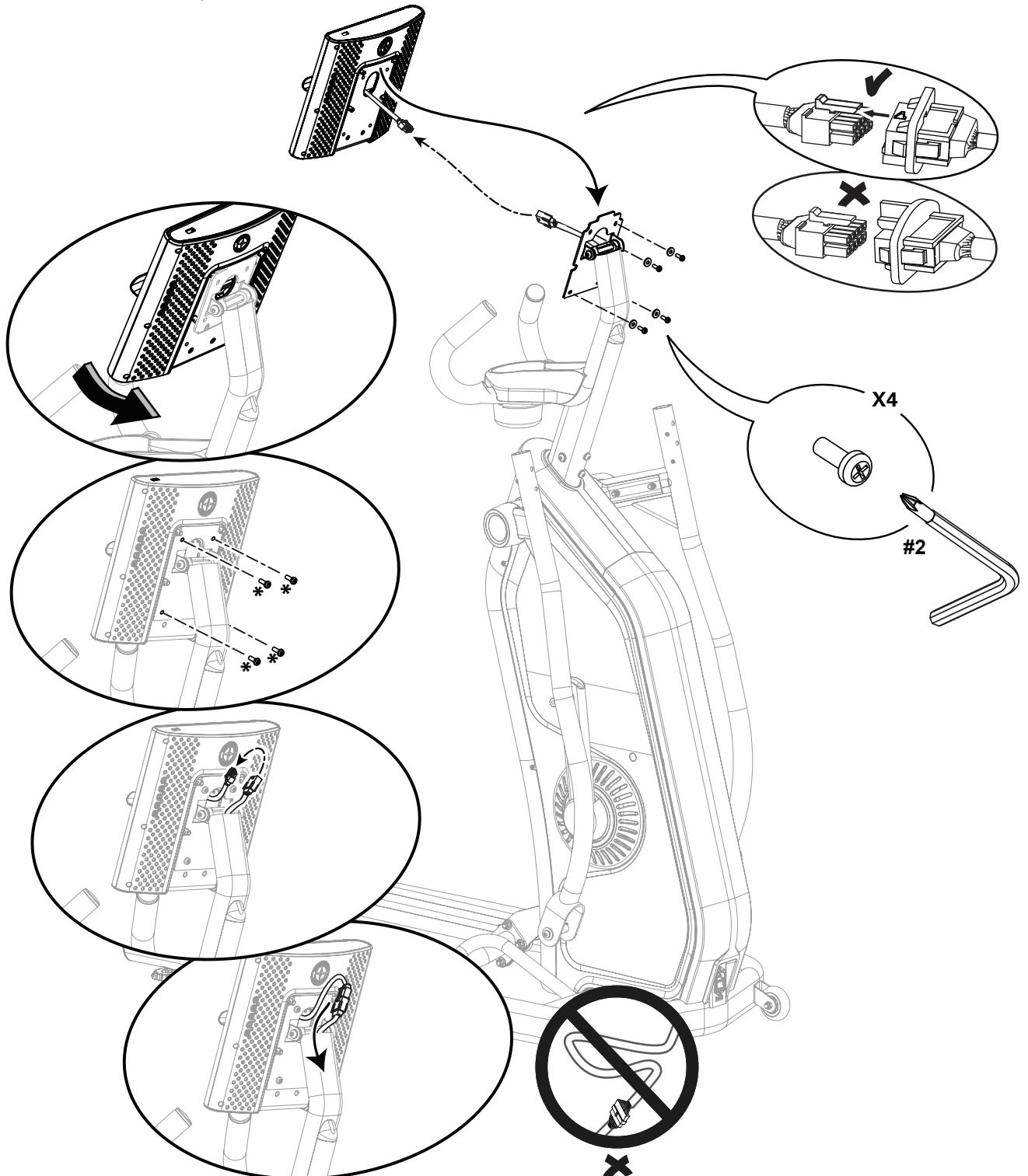

7. Replace the Console Rear Cover on the back of the Console.

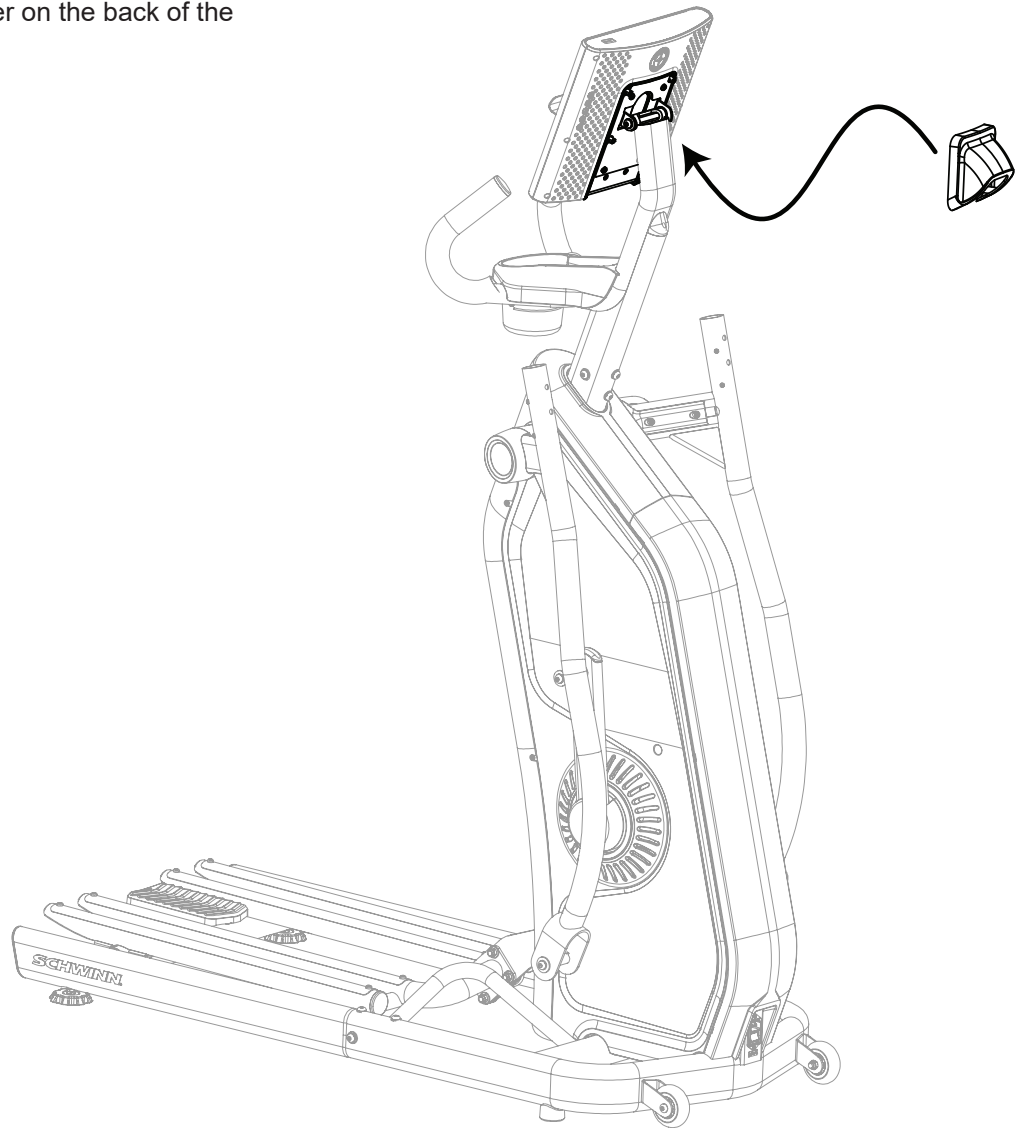

8. Final Inspection

Inspect your machine to ensure that all hardware is tight and components are properly assembled.

 Do not use until the machine has been fully assembled and inspected for correct performance in accordance with the Owner's Manual.



NOTICE: This document provides instructions for the replacement of the Console Mast on the Schwinn™ 490 / 590e Ellipticals.

If you need assistance, please contact Customer Service (if purchased in US/Canada) or your local distributor (if purchased outside US/Canada). To find your local distributor, go to: www.nautilusinternational.com

⚠ This icon means a potentially hazardous situation which, if not avoided, could result in death or serious injury. Read and understand all Warnings on this machine.

Nautilus, Inc., www.nautilus.com, 5415 Centerpoint Parkway, Groveport, OH 43125 U.S.A. - Customer Service: North America (800) 605-3369, csnls@nautilus.com | outside U.S. www.nautilusinternational.com | Printed in China | © 2023 Nautilus, Inc. | Schwinn and the Schwinn logo are trademarks owned or licensed by Nautilus, Inc., registered or otherwise protected by common law in the United States and other nations. | **ORIGINAL DOCUMENT - ENGLISH VERSION ONLY**

Important Safety Instructions - Before servicing or using this equipment, obey the following warnings:

⚠ This icon means a potentially hazardous situation which, if not avoided, could result in death or serious injury. Read and understand all Warnings on this machine.

⚠ DANGER To reduce the risk of electrical shock or unsupervised usage of the equipment, always unplug the power cord from the wall outlet and wait 5 minutes before cleaning, maintaining or repairing this machine. Place the power cord in a secure location.

- Read and understand the Part Replacement Procedure before working on the machine. Failure to obey the instructions and safety warnings could cause injury to the service technician or bystanders.
- Keep bystanders and children away from the product being serviced at all times.
- Disconnect all power to the machine before you service it.
- Make sure that the repair is done in an appropriate work space away from foot traffic and exposure to bystanders.
- Some components of the equipment can be heavy or awkward. Enlist the service of a second person when you do maintenance steps involving these components. Do not try to do heavy or awkward steps on your own.
- Use only replacement parts and hardware that are supplied or approved by Nautilus. Failure to use Nautilus-approved replacement parts can adversely affect the safety and functionality of the equipment creating a risk to users and will void the warranty.
- Be sure that all warning stickers and instructional placards applied to the product stay present and in good condition when doing maintenance or replacing components. If at any time the Warning labels become loose, unreadable or dislodged, replace the labels. If purchased in US/Canada, contact Customer Service for replacement labels. If purchased outside US/Canada, contact your local distributor for them.
- Do not try to change the design or functionality of the machine being serviced as this can adversely affect user safety.
- Do not use the machine until all shrouds, instructions, warning labels and correct functionality have been verified and tested for correct performance.

• SAVE THESE INSTRUCTIONS

Tools Required (not included)

#2 Phillips screwdriver



6mm hex wrench



⚠ DANGER

To reduce the risk of electrical shock or unsupervised usage of the equipment, always unplug the power cord from the wall outlet and wait 5 minutes before cleaning, maintaining or repairing this machine. Place the power cord in a secure location.

Note: Your machine may not match the images provided exactly. Upper Handlebars removed for clarity.

1. Unplug the AC Adapter from the wall outlet and machine.

2. Remove the Console Rear Cover from the back of the Console.

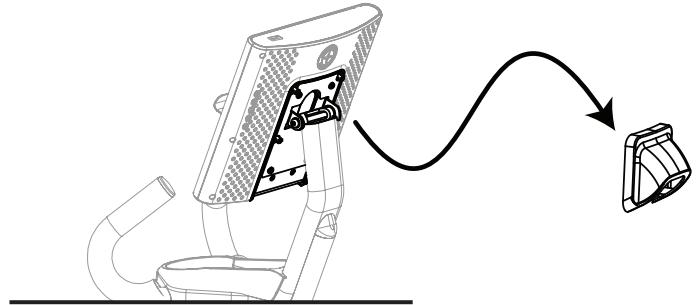

3. Remove the four screws that attach the Console to the Mast. Set the hardware safely aside for reassembly.

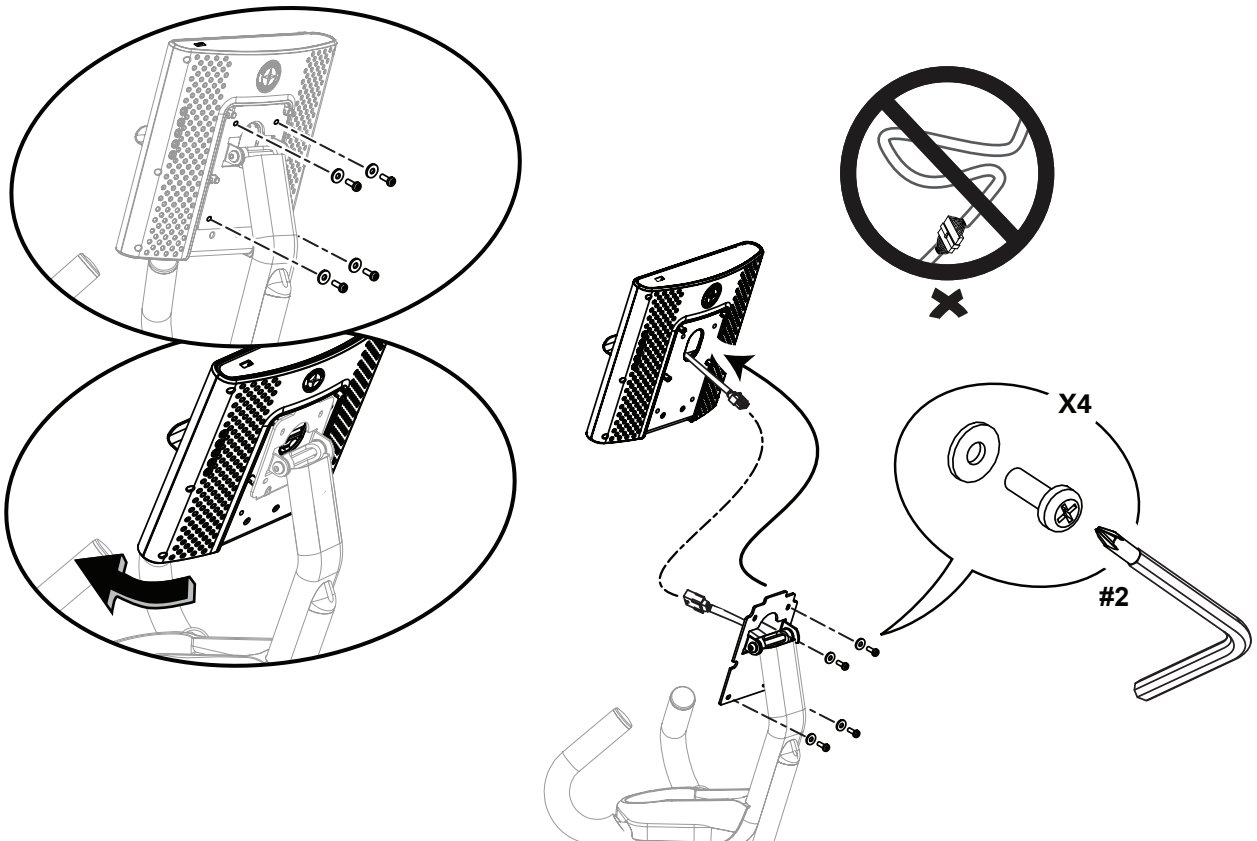

4. Disconnect the Data Cable from the back of the old Console. Carefully lift the old Console off the Mast, and set it safely aside.

Note: Do not let the cable fall down inside the Mast. This step may require two people.

NOTICE: Do not cut or pinch the cables.

5. Using a 6mm hex wrench, remove the hardware that attaches the Console Mast to the Frame Assembly.

6. Slightly pull the Console Mast upward, and disconnect the cables. Set the old Console Mast and hardware safely aside.

NOTICE: Do not cut or pinch the cables. This step may require two people.

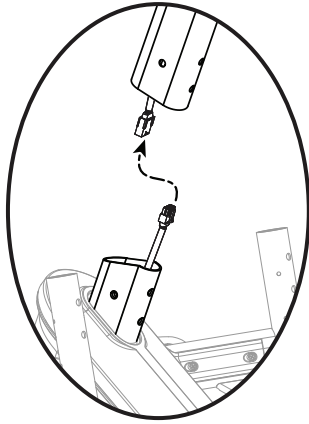

7. With the new Console Mast, connect the cable to the cable from the Frame Assembly. Align the clips on the cable connectors and make sure the connectors lock.

NOTICE: Do not cut or pinch the cables. This step may require two people.

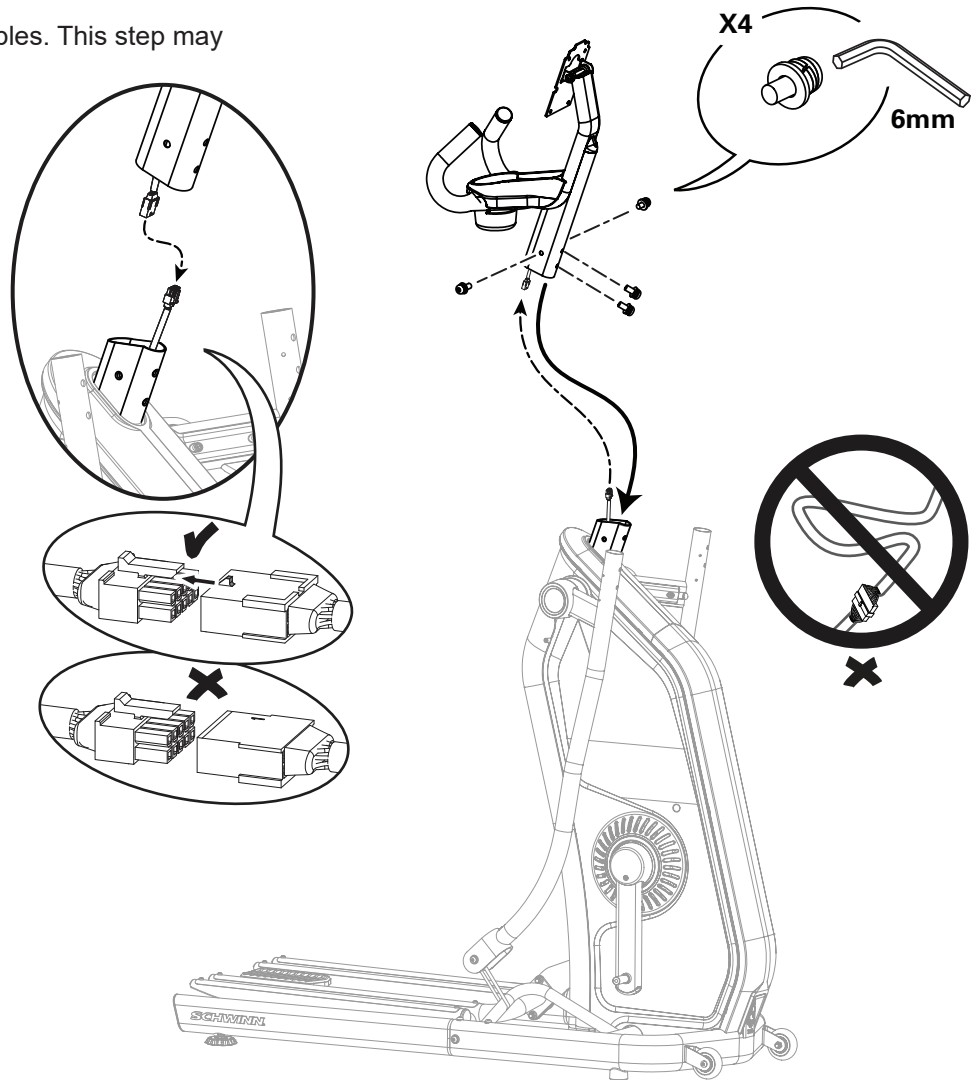

8. Using a 6mm hex wrench, attach the Console Mast to the Main Assembly.

NOTICE: Make sure the Console Cable does not fall into the Console Mast. Do not cut or pinch the cables.

9. Tilt the Console to install the wide tab at the top of the Console Mount Bracket. Route the Console cable through the bracket.

10. Attach the Console to the Console Mount Bracket before connecting the cables. Start lower screws first, then tighten all screws. Connect the Console cable to the Console Mast cable. Align the clips on the cable connectors and make sure the connectors lock. Push the extra wire down into the Console Mast.

NOTICE: Do not cut or pinch the cables.

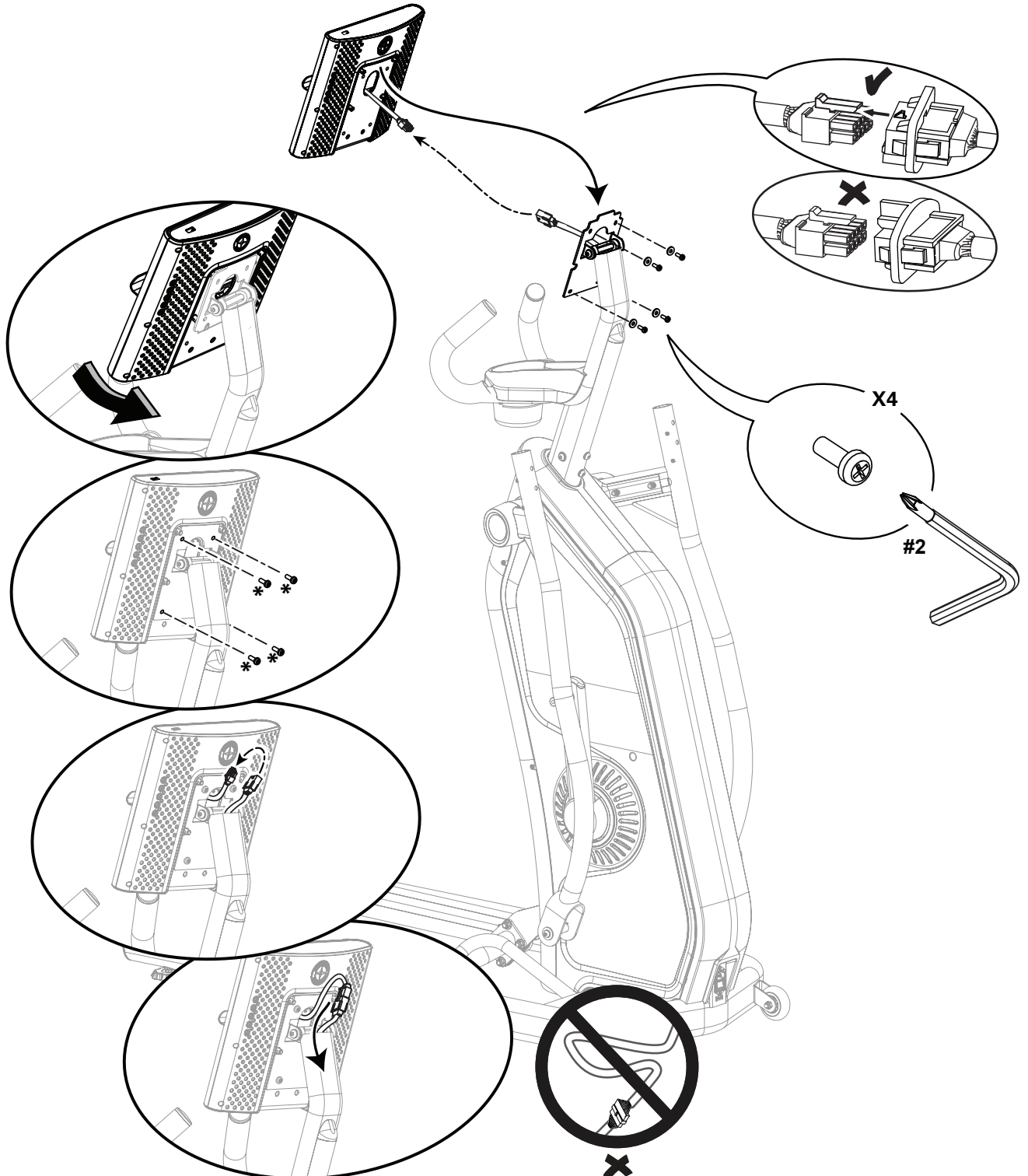

11. Replace the Console Rear Cover on the back of the Console.

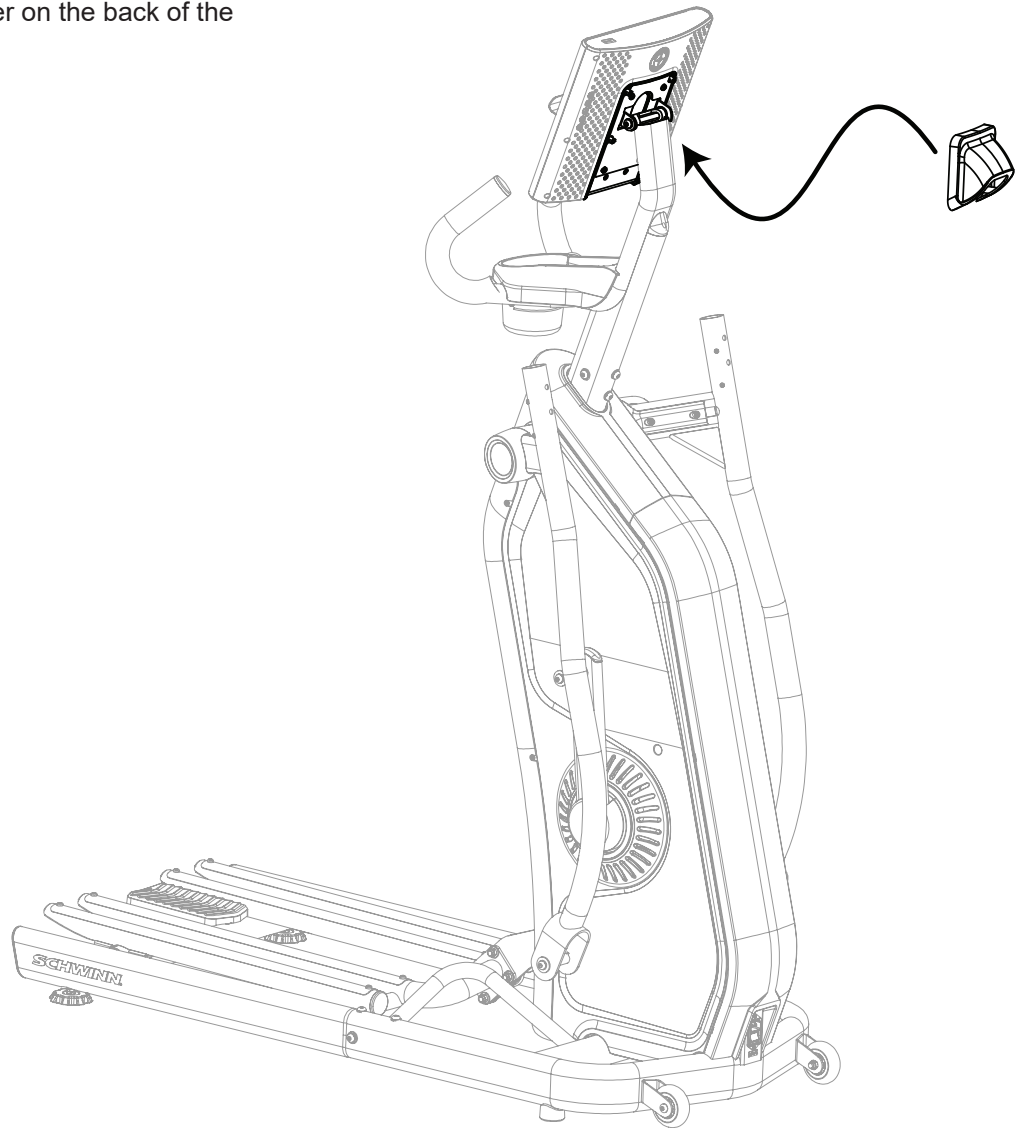

12. Final Inspection

Inspect your machine to ensure that all hardware is tight and components are properly assembled.

⚠ Do not use until the machine has been fully assembled and inspected for correct performance in accordance with the Owner's Manual.



NOTICE: This document provides instructions for the replacement of the Crank Arm on the Schwinn™ 490 / 590e Ellipticals.

If you need assistance, please contact Customer Service (if purchased in US/Canada) or your local distributor (if purchased outside US/Canada). To find your local distributor, go to: www.nautilusinternational.com

⚠ This icon means a potentially hazardous situation which, if not avoided, could result in death or serious injury. Read and understand all Warnings on this machine.

Nautilus, Inc., www.nautilus.com, 5415 Centerpoint Parkway, Groveport, OH 43125 U.S.A. - Customer Service: North America (800) 605-3369, csnls@nautilus.com | outside U.S. www.nautilusinternational.com | Printed in China | © 2023 Nautilus, Inc. | Schwinn and the Schwinn logo are trademarks owned or licensed by Nautilus, Inc., registered or otherwise protected by common law in the United States and other nations. | ORIGINAL DOCUMENT - ENGLISH VERSION ONLY

Important Safety Instructions - Before servicing or using this equipment, obey the following warnings:

⚠ This icon means a potentially hazardous situation which, if not avoided, could result in death or serious injury. Read and understand all Warnings on this machine.

⚠ DANGER To reduce the risk of electrical shock or unsupervised usage of the equipment, always unplug the power cord from the wall outlet and wait 5 minutes before cleaning, maintaining or repairing this machine. Place the power cord in a secure location.

- Read and understand the Part Replacement Procedure before working on the machine. Failure to obey the instructions and safety warnings could cause injury to the service technician or bystanders.
- Keep bystanders and children away from the product being serviced at all times.
- Disconnect all power to the machine before you service it.
- Make sure that the repair is done in an appropriate work space away from foot traffic and exposure to bystanders.
- Some components of the equipment can be heavy or awkward. Enlist the service of a second person when you do maintenance steps involving these components. Do not try to do heavy or awkward steps on your own.
- Use only replacement parts and hardware that are supplied or approved by Nautilus. Failure to use Nautilus-approved replacement parts can adversely affect the safety and functionality of the equipment creating a risk to users and will void the warranty.
- Be sure that all warning stickers and instructional placards applied to the product stay present and in good condition when doing maintenance or replacing components. If at any time the Warning labels become loose, unreadable or dislodged, replace the labels. If purchased in US/Canada, contact Customer Service for replacement labels. If purchased outside US/Canada, contact your local distributor for them.
- Do not try to change the design or functionality of the machine being serviced as this can adversely affect user safety.
- Do not use the machine until all shrouds, instructions, warning labels and correct functionality have been verified and tested for correct performance.

• SAVE THESE INSTRUCTIONS

Tools Required (not included)

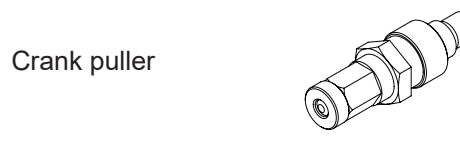
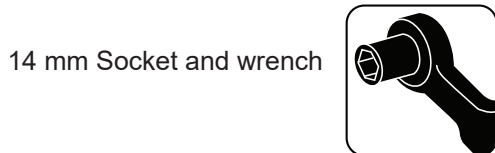
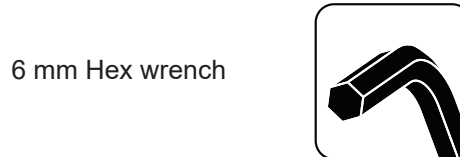
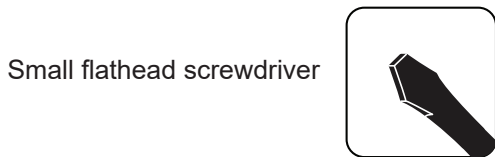
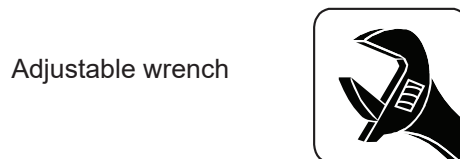
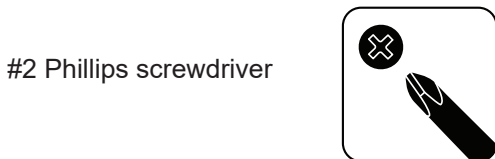

⚠ DANGER

To reduce the risk of electrical shock or unsupervised usage of the equipment, always unplug the power cord from the wall outlet and wait 5 minutes before cleaning, maintaining or repairing this machine. Place the power cord in a secure location.

Note: Your machine may not match the images provided exactly.

1. Unplug the Power Cord from the wall outlet and machine.
2. Gently compress the Exterior Handlebar Cover to release it from the Interior Handlebar Cover. There are five tabs that snap to secure each Cover.



3. Using a #2 Phillips screwdriver, remove the two screws that attach the Interior Handlebar Cover to the Handlebars. Set the hardware safely aside for reassembly.



4. Using a 6mm hex wrench, remove the four screws that attach the Upper Handlebar to the Lower Handlebar.

5. Slightly pull the Upper Handlebar out of the Lower Handlebar, and disconnect the cables. Set the old Upper Handlebar and hardware safely aside.

NOTICE: Do not cut or pinch the cables. Do not let the cable fall down into the Lower Handlebar. This step may require two people.

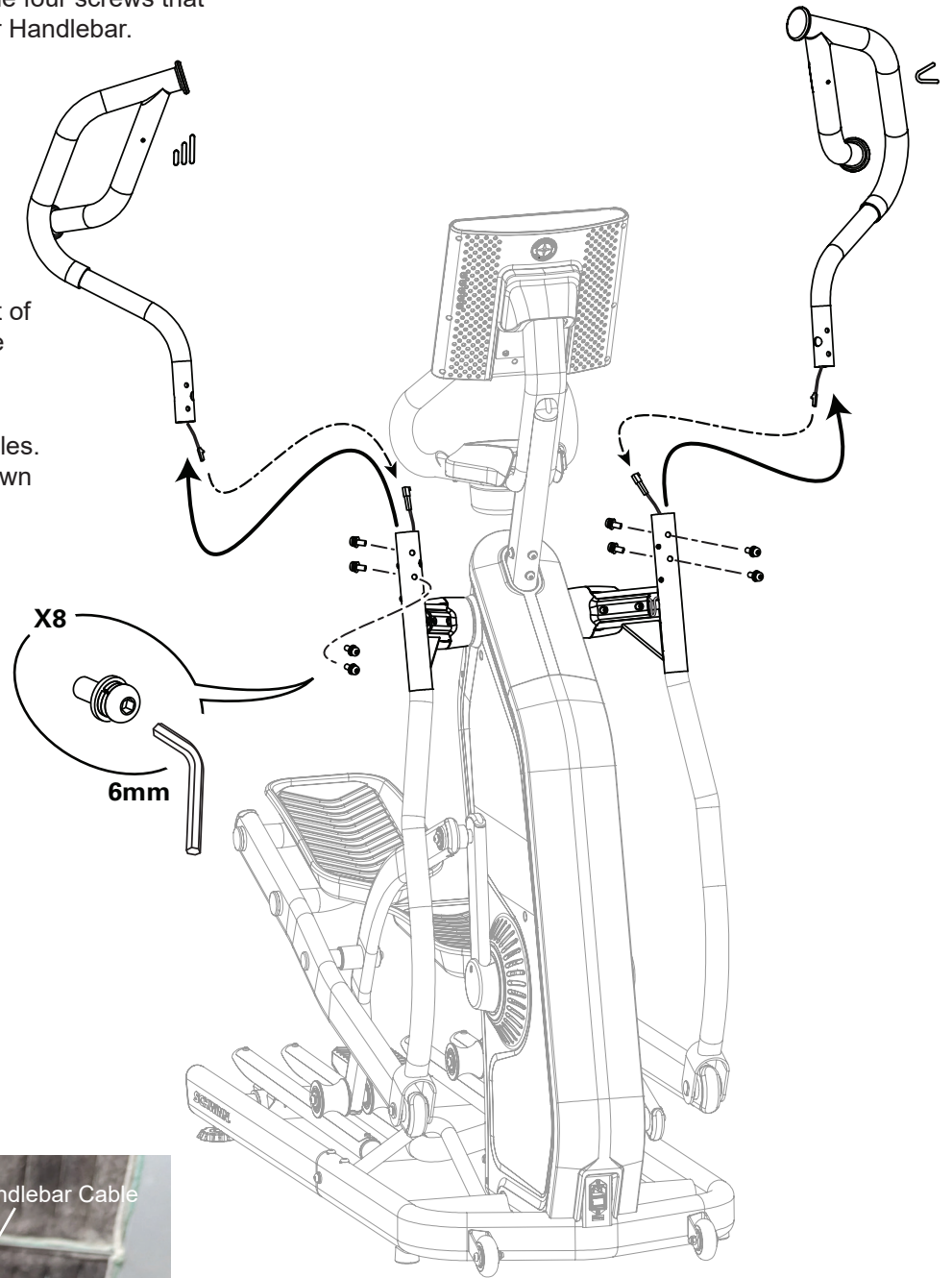

6. Using a 6mm hex wrench, remove the hardware (indicated by ovals) that attaches the Pedals and remove them.



Note: To assist with re-assembly, notice that the Pivot Pin is flush with the outside of the Lower Handlebar.

There is also a Wave Washer on the post from the Pedal.

Note: With the Pedal removed, do not fully rotate the Lower Handlebars or damage to the cables in the Handlebars will occur.

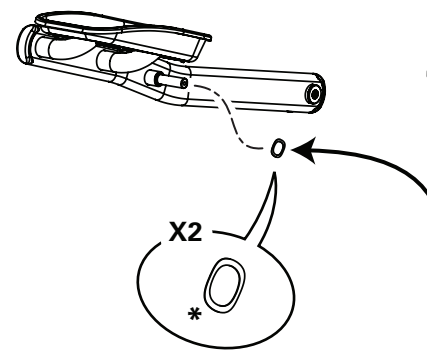

7. Using a 6mm hex wrench, remove the hardware (indicated by an oval) from the Legs and remove them.

Note: To assist with re-assembly, notice there is a Wave Washer on the post from the Crank Arm.



8. Using a #2 Phillips screwdriver, remove the indicated screw from the Crank Cap Shroud from the Crank Arm.



9. Using a 14mm wrench and socket, remove the Hex Nut from the Crank Arm.



Note: Your machine may not match the following images exactly.

10. Thread the Crank Puller into the Crank Arm (B). When the Crank Puller is in the correct position, only 1-2 threads on the outer portion (CP2) of the Crank Puller should show.

Note: Be sure the end of the Bolt (CP1) of the Crank Puller is flush with the Nut (CP2) as shown, before use.

Crank puller nut and inner bolt

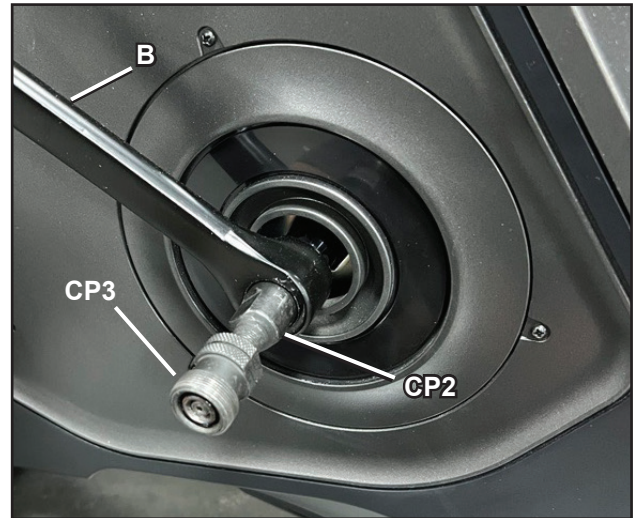
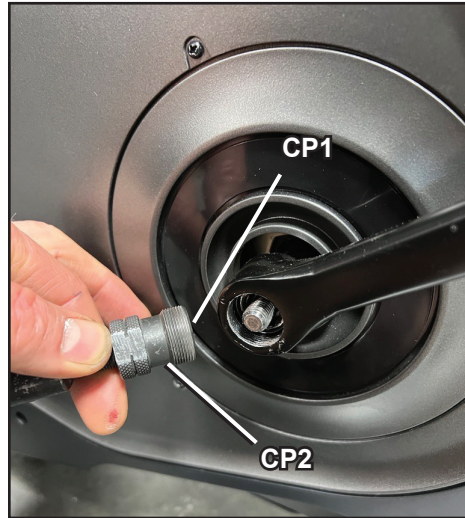

11. Using a wrench, turn the inner portion (CP3) of the Crank Puller clockwise. The Crank Arm (B) will slide off as it is tightened.

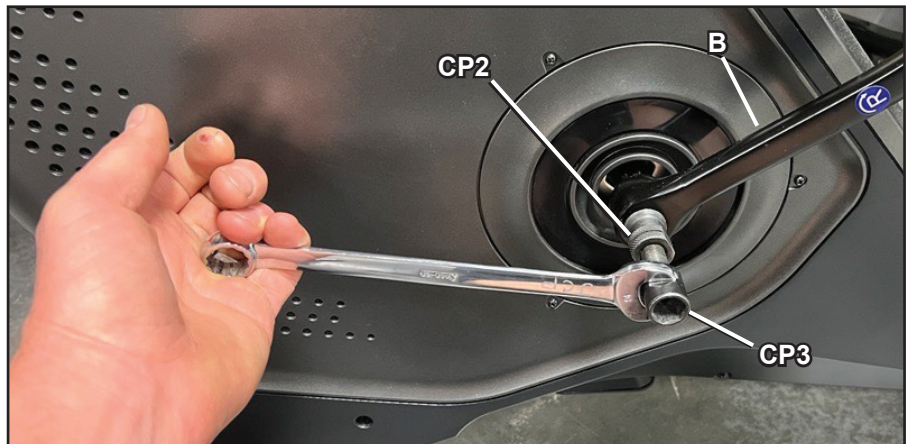

12. Installation is the reverse procedure. Installation does not require the use of the crank puller.

13. Final Inspection

Inspect your machine to ensure that all hardware is tight and components are properly assembled.

! Do not use until the machine has been fully assembled and inspected for correct performance in accordance with the Owner's Manual.

NOTICE: This document provides instructions for the replacement of the Drive Belt on the Schwinn™ 490 / 590e Ellipticals.

If you need assistance, please contact Customer Service (if purchased in US/Canada) or your local distributor (if purchased outside US/Canada). To find your local distributor, go to: www.nautilusinternational.com

⚠ This icon means a potentially hazardous situation which, if not avoided, could result in death or serious injury. Read and understand all Warnings on this machine.

Nautilus, Inc., www.nautilus.com, 5415 Centerpoint Parkway, Groveport, OH 43125 U.S.A. - Customer Service: North America (800) 605-3369, csnls@nautilus.com | outside U.S. www.nautilusinternational.com | Printed in China | © 2023 Nautilus, Inc. | Schwinn and the Schwinn logo are trademarks owned or licensed by Nautilus, Inc., registered or otherwise protected by common law in the United States and other nations. | ORIGINAL DOCUMENT - ENGLISH VERSION ONLY

Important Safety Instructions - Before servicing or using this equipment, obey the following warnings:

⚠ This icon means a potentially hazardous situation which, if not avoided, could result in death or serious injury. Read and understand all Warnings on this machine.

⚠ DANGER To reduce the risk of electrical shock or unsupervised usage of the equipment, always unplug the power cord from the wall outlet and wait 5 minutes before cleaning, maintaining or repairing this machine. Place the power cord in a secure location.

- Read and understand the Part Replacement Procedure before working on the machine. Failure to obey the instructions and safety warnings could cause injury to the service technician or bystanders.
- Keep bystanders and children away from the product being serviced at all times.
- Disconnect all power to the machine before you service it.
- Make sure that the repair is done in an appropriate work space away from foot traffic and exposure to bystanders.
- Some components of the equipment can be heavy or awkward. Enlist the service of a second person when you do maintenance steps involving these components. Do not try to do heavy or awkward steps on your own.
- Use only replacement parts and hardware that are supplied or approved by Nautilus. Failure to use Nautilus-approved replacement parts can adversely affect the safety and functionality of the equipment creating a risk to users and will void the warranty.
- Be sure that all warning stickers and instructional placards applied to the product stay present and in good condition when doing maintenance or replacing components. If at any time the Warning labels become loose, unreadable or dislodged, replace the labels. If purchased in US/Canada, contact Customer Service for replacement labels. If purchased outside US/Canada, contact your local distributor for them.
- Do not try to change the design or functionality of the machine being serviced as this can adversely affect user safety.
- Do not use the machine until all shrouds, instructions, warning labels and correct functionality have been verified and tested for correct performance.

• SAVE THESE INSTRUCTIONS

Tools Required (not included)

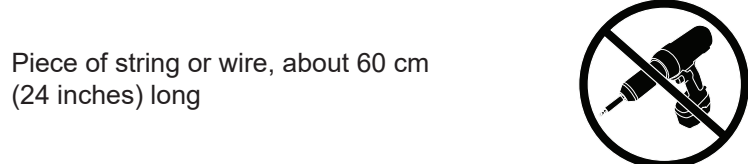
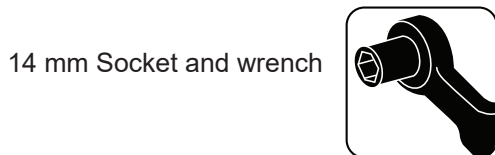
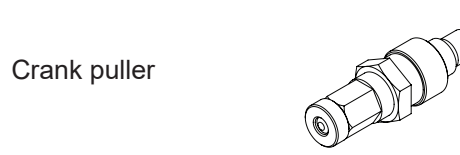
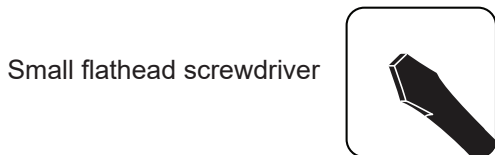
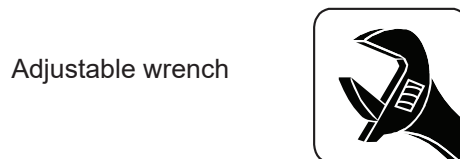
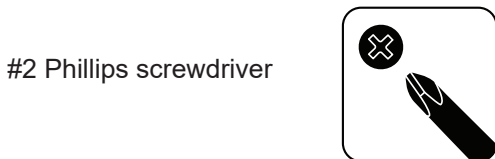

⚠ DANGER

To reduce the risk of electrical shock or unsupervised usage of the equipment, always unplug the power cord from the wall outlet and wait 5 minutes before cleaning, maintaining or repairing this machine. Place the power cord in a secure location.

Note: Your machine may not match the images provided exactly.

1. Unplug the Power Cord from the wall outlet and machine.

2. Flex the edges of the Front Lower Shroud to disengage the 8 inside tabs from the Main Shrouds.

Note: It may be easier to pry up the edges of the Front Lower Shroud using a flathead screwdriver. To avoid damage to the surface of the Shrouds, we recommend putting a piece of cloth over the screwdriver blade.

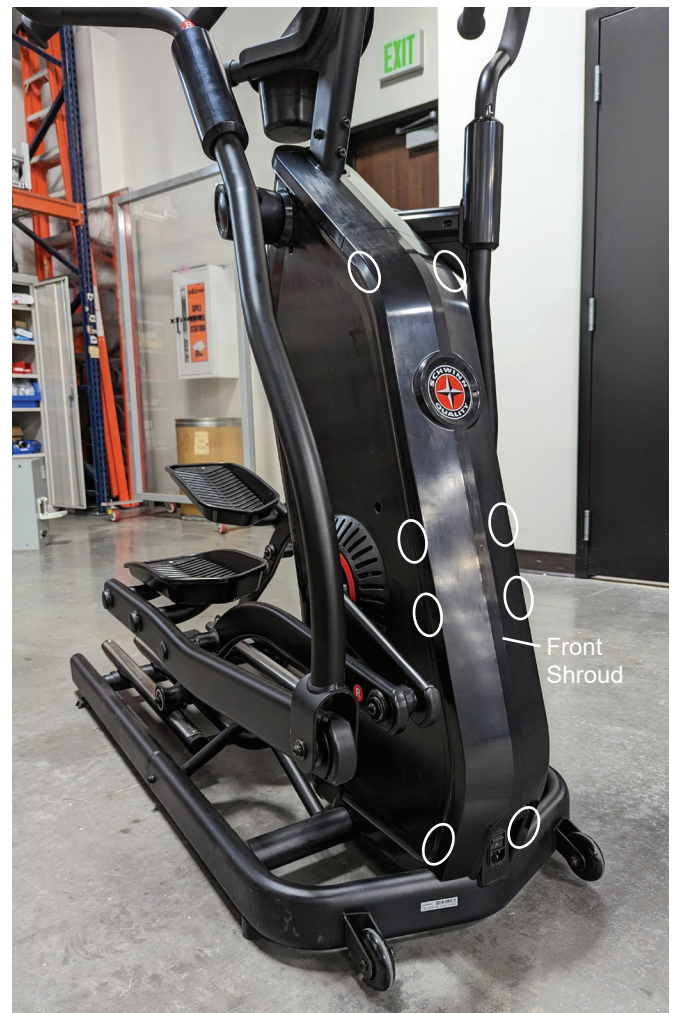

3. Flex the edges of the Front Upper Shroud to disengage the 4 inside tabs (2 on each side) from the Main Shrouds.



4. Using a #2 Phillips screwdriver, remove the 4 screws (2 indicated on this side of the machine by ovals) from the Rear Shroud.

5. Gently pivot the Rear Shroud down along the Incline (Lift) Motor Arm.



6. Gently compress the left Exterior Handlebar Cover to release it from the left Interior Handlebar Cover. There are five tabs that snap to secure each Cover.



7. Using a #2 Phillips screwdriver, remove the two screws that attach the Left Interior Handlebar Cover to the Handlebars. Set the hardware safely aside for reassembly.



8. Using a 6mm hex wrench, remove the four screws that attach the Left Upper Handlebar to the Left Lower Handlebar.

9. Slightly pull the Left Upper Handlebar out of the Left Lower Handlebar, and disconnect the cables. Set the Left Upper Handlebar and hardware safely aside.

NOTICE: Do not cut or pinch the cables. Do not let the cable fall down into the Left Lower Handlebar. This step may require two people.

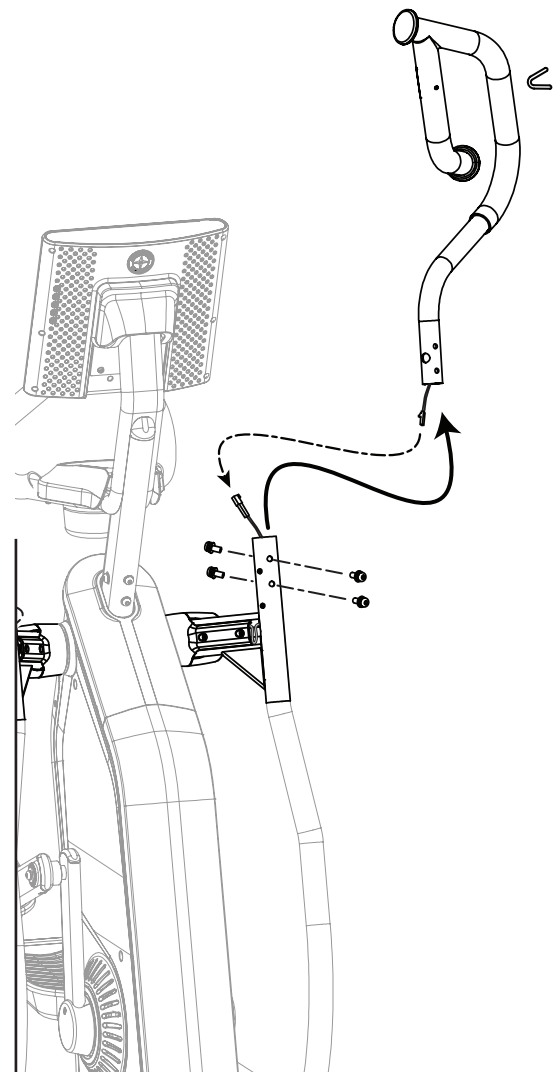

10. Using a 6mm hex wrench, remove the hardware (indicated by ovals) that attaches the Left Pedal and remove it.



Note: To assist with re-assembly, notice that the Pivot Pin is flush with the outside of the Lower Handlebar.



There is also a Wave Washer on the post from the Pedal.

Note: With the Pedal removed, do not fully rotate the Left Lower Handlebar or damage to the cables in the Handlebars will occur.

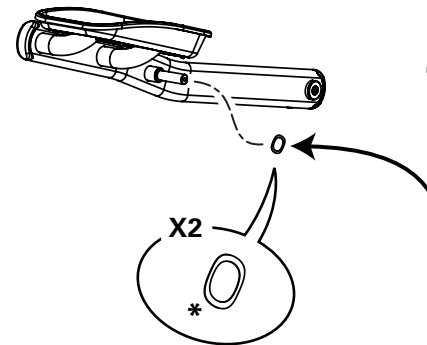

11. Using a 6mm hex wrench, remove the hardware (indicated by an oval) from the Left Leg and remove it.

Note: To assist with re-assembly, notice there is a Wave Washer on the post from the Crank Arm.



12. Using a #2 Phillips screwdriver, remove the indicated screw from the Crank Cap Shroud from the Crank Arm.



13. Using a 14mm wrench and socket, remove the Hex Nut from the Crank Arm.



Note: Your machine may not match the following images exactly.

14. Thread the Crank Puller into the Crank Arm (B). When the Crank Puller is in the correct position, only 1-2 threads on the outer portion (CP2) of the Crank Puller should show.

Note: Be sure the end of the Bolt (CP1) of the Crank Puller is flush with the Nut (CP2) as shown, before use.

Crank puller nut and inner bolt

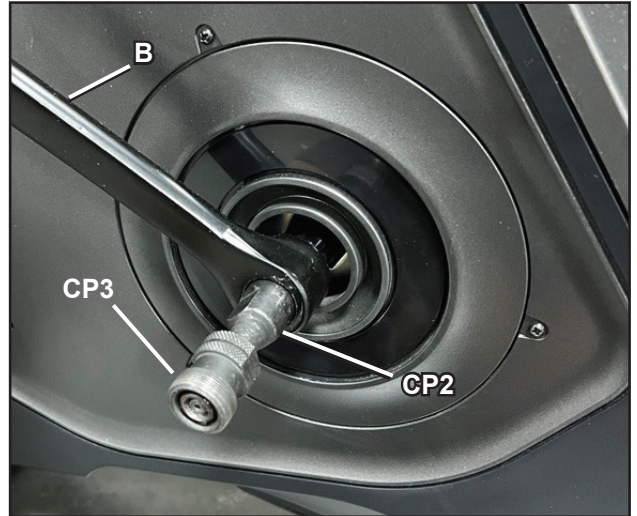
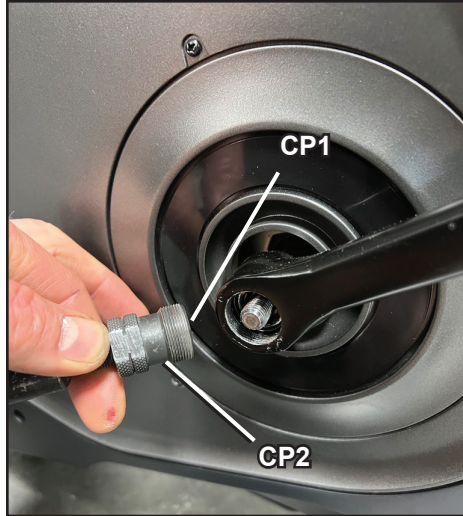

15. Using a wrench, turn the inner portion (CP3) of the Crank Puller clockwise. The Crank Arm (B) will slide off as it is tightened.

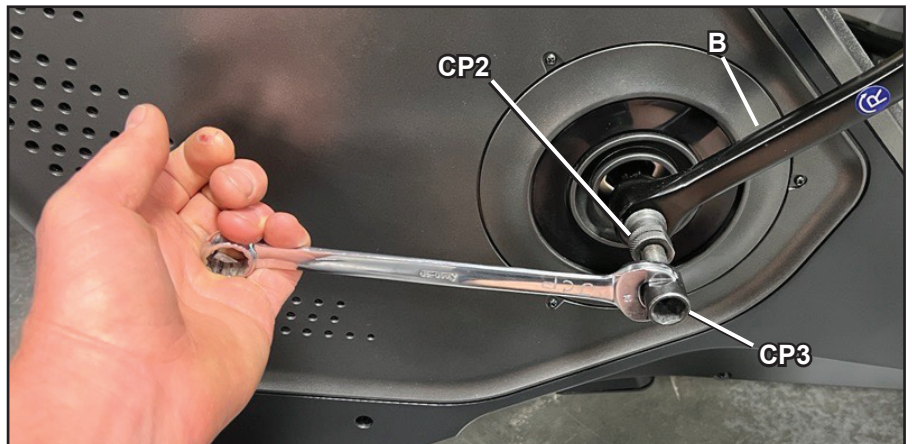

16. Gently compress the sides of the Pivot Cap to release it from the Inner Pivot Shroud.

17. Using a #2 Phillips screwdriver, remove the 2 screws from the Inner Pivot Shroud.

18. Tie a 60 cm (24 inch) long piece of wire or string to the end of the Cable. This wire or string will be used to pull the new cable through and out of the Lower Handlebar.

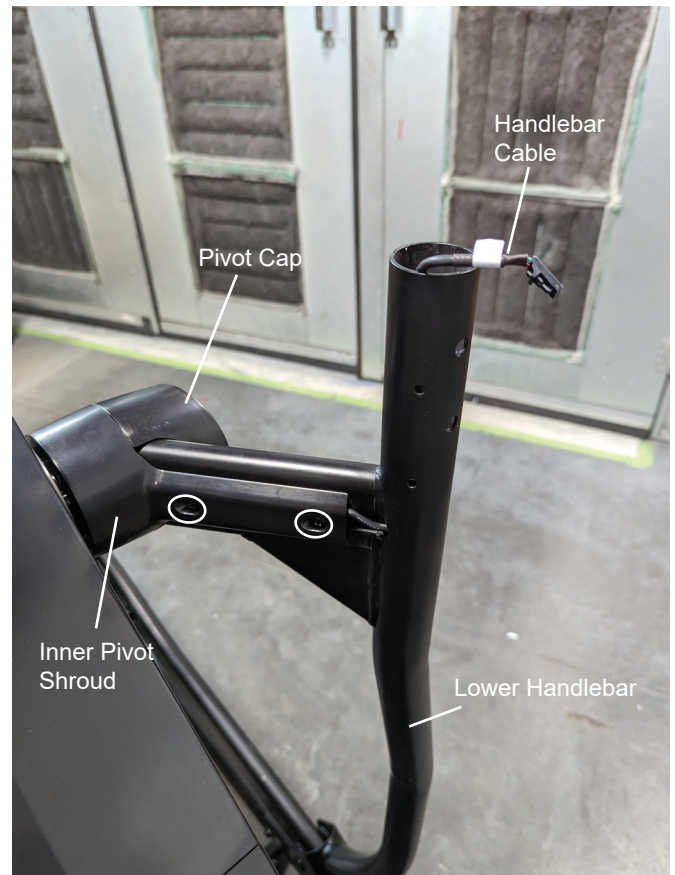

19. Using a 6mm hex wrench, remove the hardware (indicated by oval) that secures the Lower Handlebar.

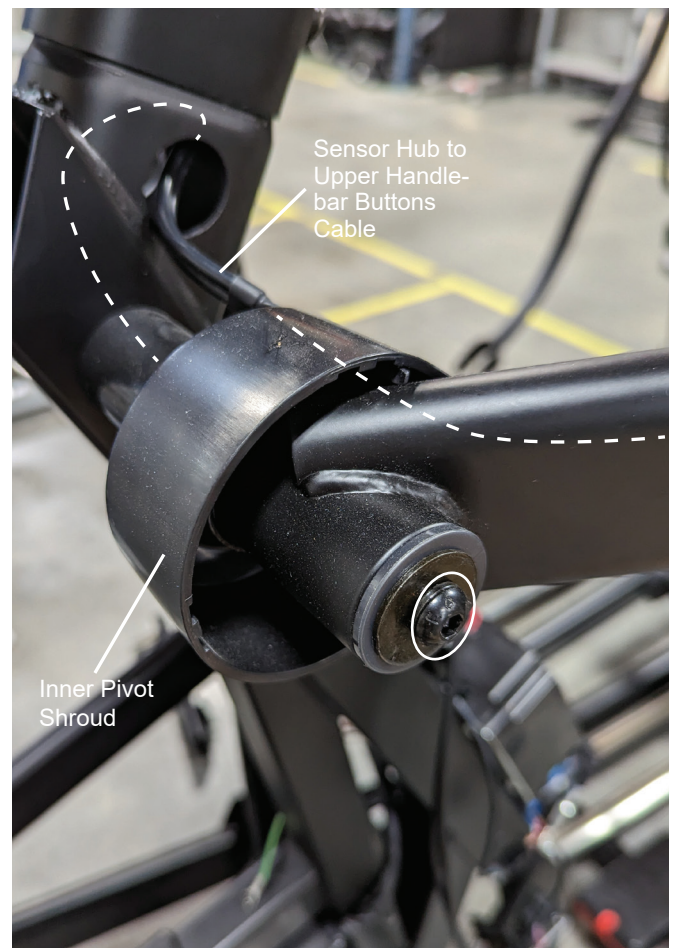

20. Slide the Lower Handlebar outward only about 1 inch (2.5 cm) from the machine.

21. Push the Inner Pivot Shroud toward the machine, off of the Lower Handlebar. This will release the Cable from the clips on the Inner Pivot Shroud.

22. With the wire or string still attached to the end of the Cable, pull the Cable toward the machine out of the Lower Handlebar. Be sure not to pull the end of the wire or string into the Lower Handlebar.

23. Remove the wire or string from the Cable, and tie the wire or string off at both ends of the Lower Handlebar. This will be used to route the Cable back through the Lower Handlebar.

24. Fully remove the Lower Handlebar from the Pivot Rod.

25. Using a #2 Phillips screwdriver, remove the 4 screws (indicated by ovals) from the Right Main Shroud. These screws connect to the Left Main Shroud.

Note: The Upper Front Shroud may need to be lifted to access the upper screw for the Right Main Shroud.



Note: Crank Arm and Lower Handlebar have been removed, but are shown here.

26. Using a #2 Phillips screwdriver, remove the 3 screws from the Left Main Shroud. Remove the Left Main Shroud and place outside the work area.



Note: Crank Arm and Lower Handlebar have been removed, but are shown here.

27. Using a 13mm wrench, loosen the Tensioner Nut enough so that the Drive Belt can be removed. Be sure to record the number of turns performed to the Tensioner Nut so it can be reset to that tension during re-assembly.

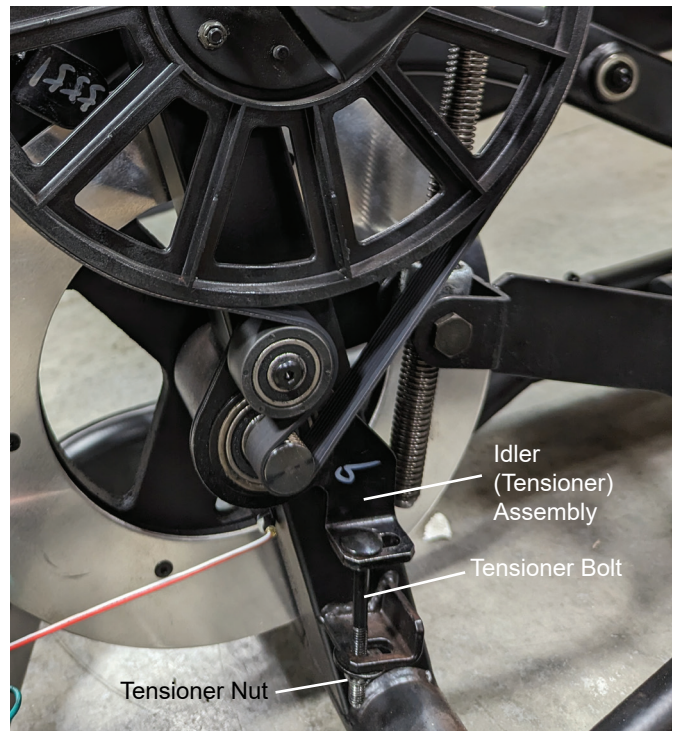

28. Remove the old Drive Belt after noting how to properly route the new Belt. Slowly turn the Drive Pulley backward and carefully ease the Drive Belt off the Drive Pulley to the outside.



Be sure to keep fingers clear of all pinch hazards as you turn the Drive Pulley.

NOTICE: Be sure not to pinch or cut any cables.

29. Put the new Drive Belt in position on the Flywheel Pulley. Put the Drive Belt in position around the Tensioner Assembly. Be sure that the lower portion of the Drive Belt is above the Tensioner bearings on the Tensioner Assembly. Slowly turn the Drive Pulley backward and carefully ease the Drive Belt onto the Drive Pulley.

NOTICE: Be sure not to pinch or cut any cables.

30. Make sure the Drive Belt is aligned on the Flywheel Pulley, Belt Tensioner and Drive Pulley.



31. Using a 13mm wrench, tighten the Tensioner Nut the number of turns recorded to remove the Drive Belt.

32. Re-install all remaining parts that were removed in reverse order.

Installation of the Crank Arm does not require the use of the crank puller.

33. Final Inspection

Inspect your machine to ensure that all hardware is tight and components are properly assembled.



Do not use until the machine has been fully assembled and inspected for correct performance in accordance with the Owner's Manual.

NOTICE: This document provides instructions for the replacement of the Drive Pulley on the Schwinn™ 490 / 590e Ellipticals.

If you need assistance, please contact Customer Service (if purchased in US/Canada) or your local distributor (if purchased outside US/Canada). To find your local distributor, go to: www.nautilusinternational.com

⚠ This icon means a potentially hazardous situation which, if not avoided, could result in death or serious injury. Read and understand all Warnings on this machine.

Nautilus, Inc., www.nautilus.com, 5415 Centerpoint Parkway, Groveport, OH 43125 U.S.A. - Customer Service: North America (800) 605-3369, csnls@nautilus.com | outside U.S. www.nautilusinternational.com | Printed in China | © 2023 Nautilus, Inc. | Schwinn and the Schwinn logo are trademarks owned or licensed by Nautilus, Inc., registered or otherwise protected by common law in the United States and other nations. | ORIGINAL DOCUMENT - ENGLISH VERSION ONLY

Important Safety Instructions - Before servicing or using this equipment, obey the following warnings:









⚠ This icon means a potentially hazardous situation which, if not avoided, could result in death or serious injury. Read and understand all Warnings on this machine.

⚠ DANGER To reduce the risk of electrical shock or unsupervised usage of the equipment, always unplug the power cord from the wall outlet and wait 5 minutes before cleaning, maintaining or repairing this machine. Place the power cord in a secure location.

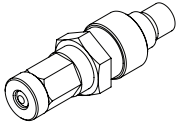
- Read and understand the Part Replacement Procedure before working on the machine. Failure to obey the instructions and safety warnings could cause injury to the service technician or bystanders.
- Keep bystanders and children away from the product being serviced at all times.
- Disconnect all power to the machine before you service it.
- Make sure that the repair is done in an appropriate work space away from foot traffic and exposure to bystanders.
- Some components of the equipment can be heavy or awkward. Enlist the service of a second person when you do maintenance steps involving these components. Do not try to do heavy or awkward steps on your own.
- Use only replacement parts and hardware that are supplied or approved by Nautilus. Failure to use Nautilus-approved replacement parts can adversely affect the safety and functionality of the equipment creating a risk to users and will void the warranty.
- Be sure that all warning stickers and instructional placards applied to the product stay present and in good condition when doing maintenance or replacing components. If at any time the Warning labels become loose, unreadable or dislodged, replace the labels. If purchased in US/Canada, contact Customer Service for replacement labels. If purchased outside US/Canada, contact your local distributor for them.
- Do not try to change the design or functionality of the machine being serviced as this can adversely affect user safety.
- Do not use the machine until all shrouds, instructions, warning labels and correct functionality have been verified and tested for correct performance.

• SAVE THESE INSTRUCTIONS

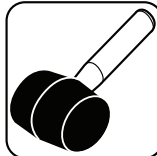
Tools Required (not included)

#2 Phillips screwdriver		Needlenose pliers		Crank puller	
Small flathead screwdriver		Snap ring pliers		Adjustable wrench	
14 mm Socket and wrench		Dead blow hammer or rubber mallet and punch		Safety goggles or other eye protection	
				Piece of string or wire, about 60 cm (24 inches) long	

⚠ DANGER

To reduce the risk of electrical shock or unsupervised usage of the equipment, always unplug the power cord from the wall outlet and wait 5 minutes before cleaning, maintaining or repairing this machine. Place the power cord in a secure location.

Note: Your machine may not match the images provided exactly.

1. Unplug the Power Cord from the wall outlet and machine.

2. Flex the edges of the Front Lower Shroud to disengage the 8 inside tabs from the Main Shrouds.

Note: It may be easier to pry up the edges of the Front Lower Shroud using a flathead screwdriver. To avoid damage to the surface of the Shrouds, we recommend putting a piece of cloth over the screwdriver blade.

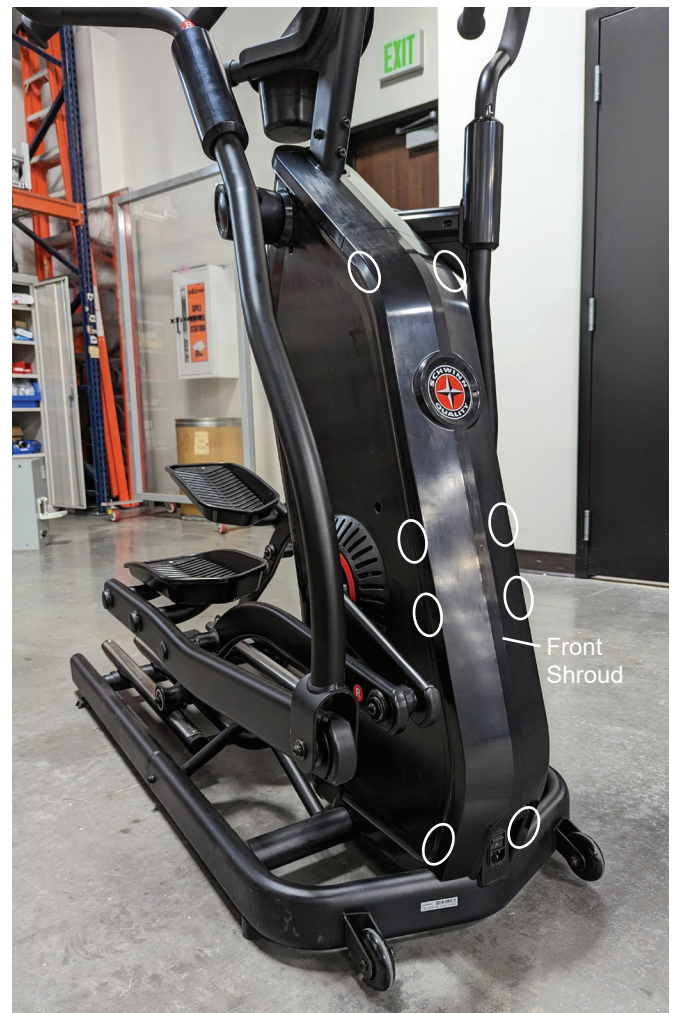

3. Flex the edges of the Front Upper Shroud to disengage the 4 inside tabs (2 on each side) from the Main Shrouds.



4. Using a #2 Phillips screwdriver, remove the 4 screws (2 indicated on this side of the machine by ovals) from the Rear Shroud.

5. Gently pivot the Rear Shroud down along the Incline (Lift) Motor Arm.



6. Gently compress the left Exterior Handlebar Cover to release it from the left Interior Handlebar Cover. There are five tabs that snap to secure each Cover.



7. Using a #2 Phillips screwdriver, remove the two screws that attach the Left Interior Handlebar Cover to the Handlebars. Set the hardware safely aside for reassembly.



8. Using a 6mm hex wrench, remove the four screws that attach the Upper Handlebar to the Lower Handlebar.

9. Slightly pull the Upper Handlebar out of the Lower Handlebar, and disconnect the cables. Set the Upper Handlebar and hardware safely aside.

NOTICE: Do not cut or pinch the cables. Do not let the cable fall down into the Lower Handlebar. This step may require two people.

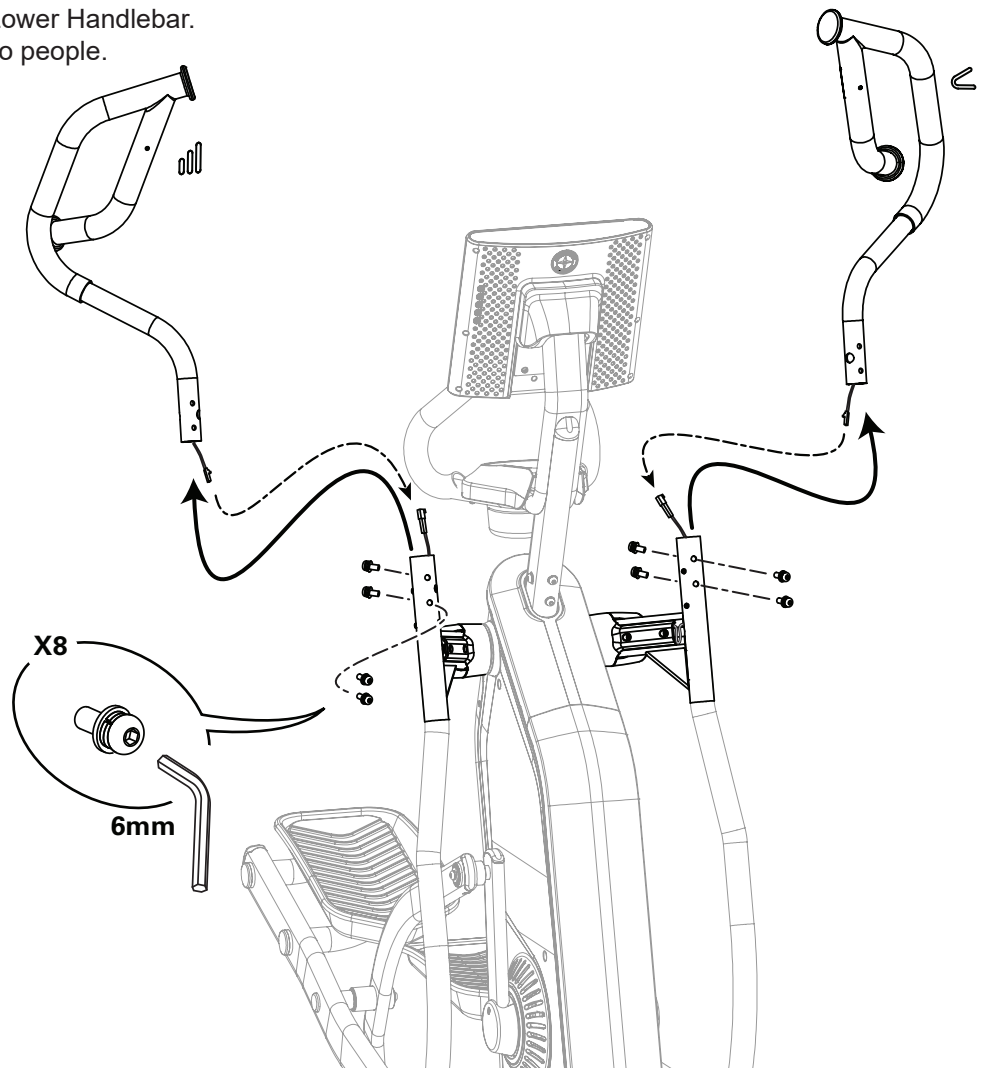

10. Using a 6mm hex wrench, remove the hardware (indicated by ovals) that attaches the Pedals and remove them.



Note: To assist with re-assembly, notice that the Pivot Pin is flush with the outside of the Lower Handlebar.

There is also a Wave Washer on the post from the Pedal.

Note: With the Pedals removed, do not fully rotate the Lower Handlebar or damage to the cables in the Handlebars will occur.

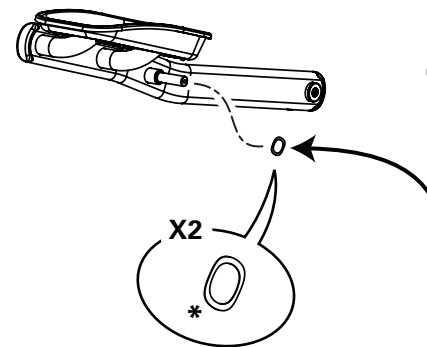

11. Using a 6mm hex wrench, remove the hardware (indicated by an oval) from the Legs and remove them.

Note: To assist with re-assembly, notice there is a Wave Washer on the post from the Crank Arm.



12. Using a #2 Phillips screwdriver, remove the indicated screw from the Crank Cap Shroud from the Crank Arm.



13. Using a 14mm wrench and socket, remove the Hex Nut from the Crank Arm.



Note: Your machine may not match the following images exactly.

14. Thread the Crank Puller into the Crank Arm (B). When the Crank Puller is in the correct position, only 1-2 threads on the outer portion (CP2) of the Crank Puller should show.

Note: Be sure the end of the Bolt (CP1) of the Crank Puller is flush with the Nut (CP2) as shown, before use.

Crank puller nut and inner bolt

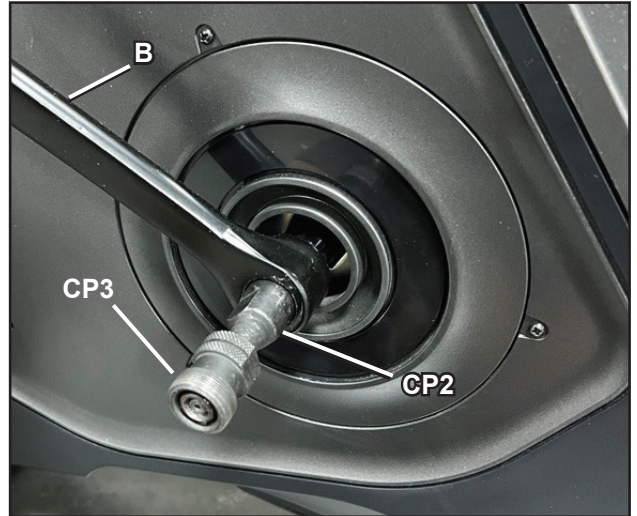
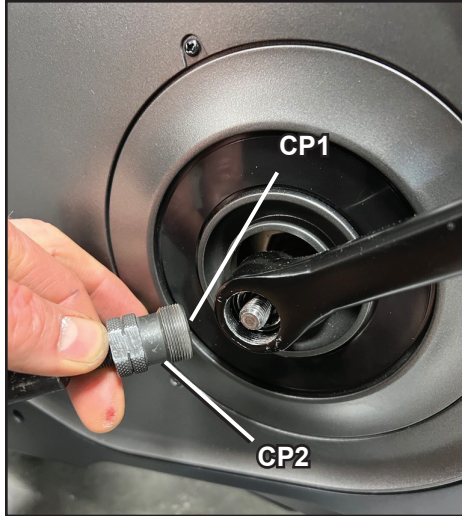

15. Using a wrench, turn the inner portion (CP3) of the Crank Puller clockwise. The Crank Arm (B) will slide off as it is tightened.

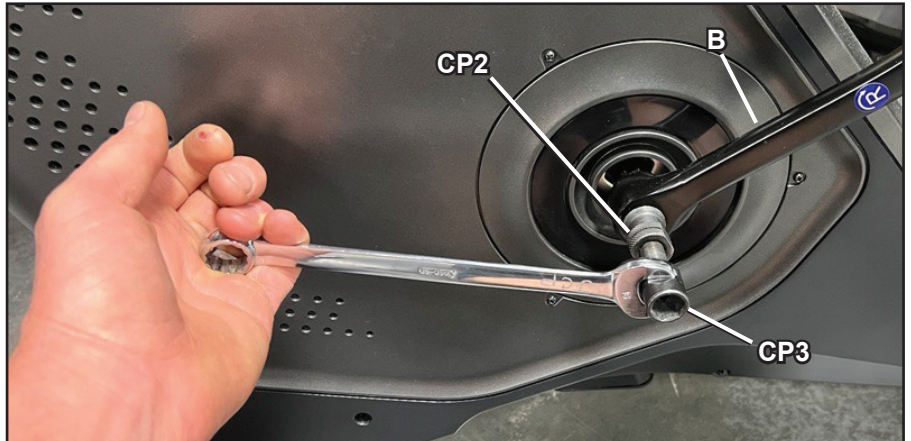

16. Gently compress the sides of the Pivot Cap to release it from the Inner Pivot Shroud.

17. Using a #2 Phillips screwdriver, remove the 2 screws from the Inner Pivot Shroud.

18. Tie a 60 cm (24 inch) long piece of wire or string to the end of the Cable. This wire or string will be used to pull the new cable through and out of the Lower Handlebar.

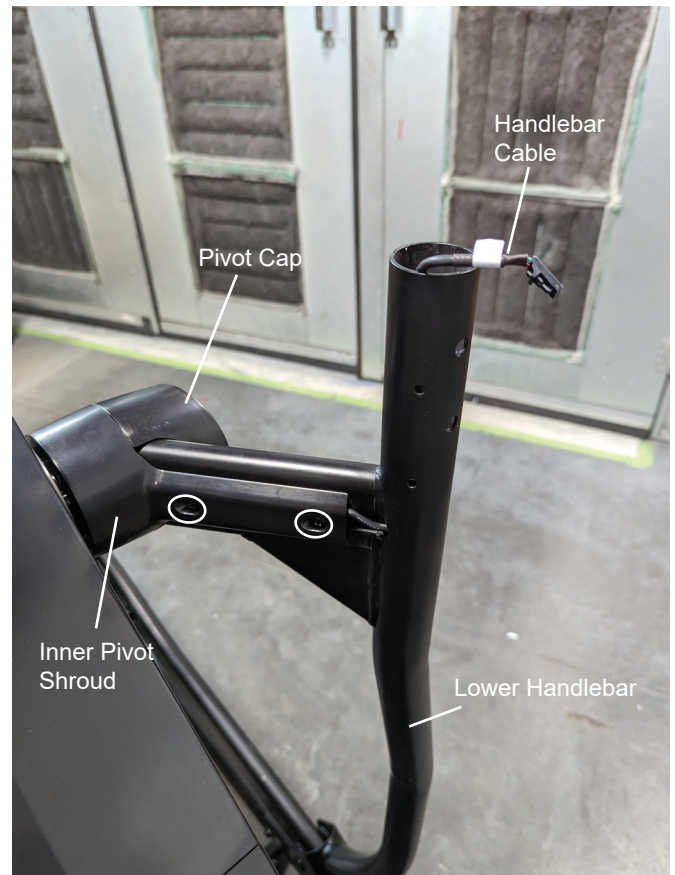

19. Using a 6mm hex wrench, remove the hardware (indicated by oval) that secures the Lower Handlebar.

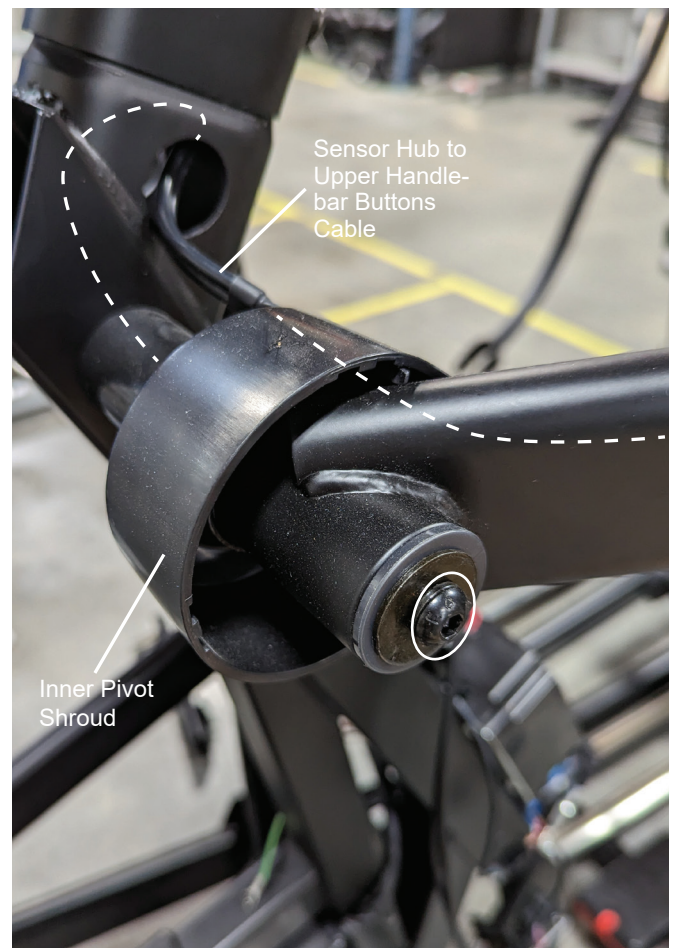

20. Slide the Lower Handlebar outward only about 1 inch (2.5 cm) from the machine.

21. Push the Inner Pivot Shroud toward the machine, off of the Lower Handlebar. This will release the Cable from the clips on the Inner Pivot Shroud.

22. With the wire or string still attached to the end of the Cable, pull the Cable toward the machine out of the Lower Handlebar. Be sure not to pull the end of the wire or string into the Lower Handlebar.

23. Remove the wire or string from the Cable, and tie the wire or string off at both ends of the Lower Handlebar. This will be used to route the Cable back through the Lower Handlebar.

24. Fully remove the Lower Handlebar from the Pivot Rod.

25. Using a #2 Phillips screwdriver, remove the 8 screws (indicated by ovals) from the Right Main Shroud. These screws connect to the Left Main Shroud.

Note: The Upper Front Shroud may need to be lifted to access the upper screw for the Right Main Shroud.



Note: Crank Arm and Lower Handlebar have been removed, but are shown here.

26. Using a #2 Phillips screwdriver, remove the 3 screws from the Left Main Shroud. Remove the Left Main Shroud and place outside the work area.



Note: Crank Arm and Lower Handlebar have been removed, but are shown here.

27. Using a 13mm wrench, loosen the Tensioner Nut enough so that the Drive Belt can be removed. Be sure to record the number of turns performed to the Tensioner Nut so it can be reset to that tension during re-assembly.

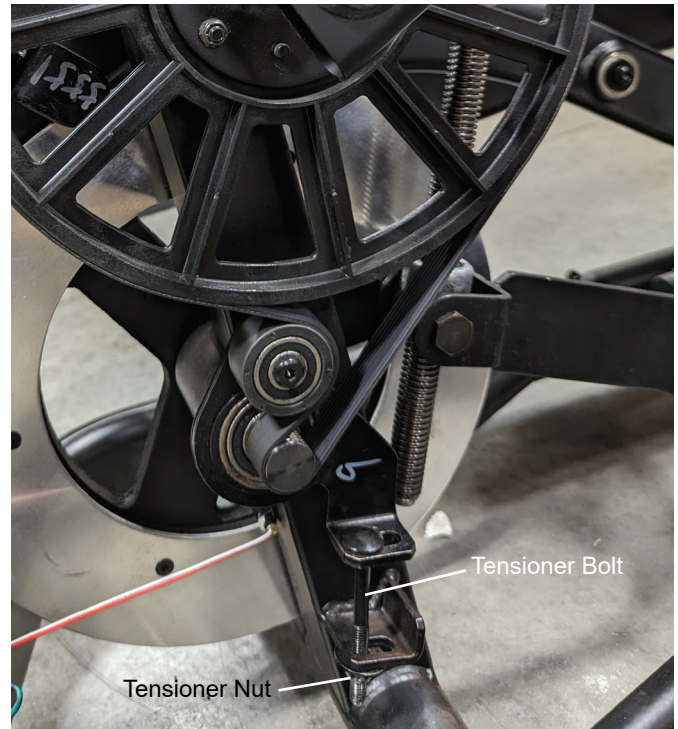

28. Remove the Drive Belt after noting how to properly route the Belt. Slowly turn the Drive Pulley backward and carefully ease the Drive Belt off the Drive Pulley to the outside.



Be sure to keep fingers clear of all pinch hazards as you turn the Drive Pulley.

NOTICE: Be sure not to pinch or cut any cables.



29. Using eye protection and snap ring pliers, remove the Snap Ring from the Drive Pulley Shaft on the right side of the machine.

Remove the Washer from the Drive Pulley Shaft.

Right side

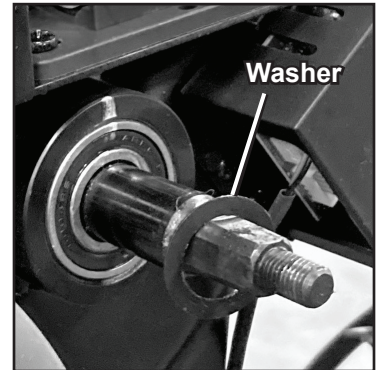
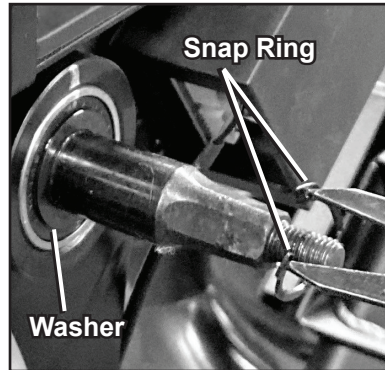
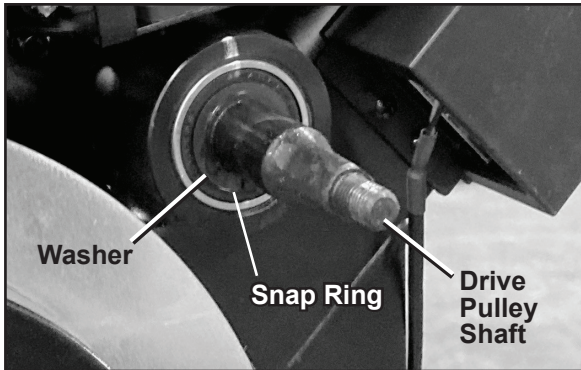

30. Using eye protection and a dead blow hammer (and punch, if needed), gently tap the Pulley Shaft until it works out of the Frame and releases the Drive Pulley.

Note: Support the Drive Pulley so that it does not fall.
The Crank Bearings will be left in the Frame after the axle is removed.

Set the old Drive Pulley and hardware safely aside.

Gently tap the drive pulley shaft (Right side of machine)

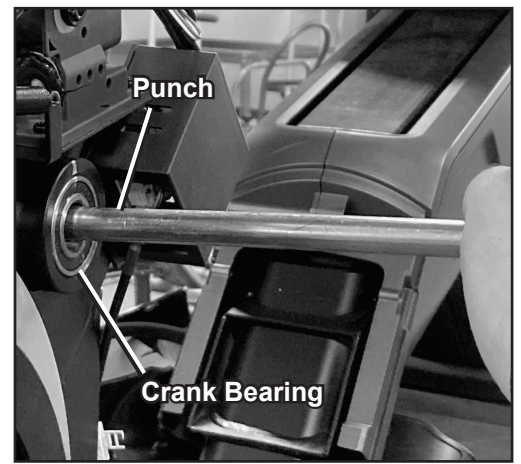
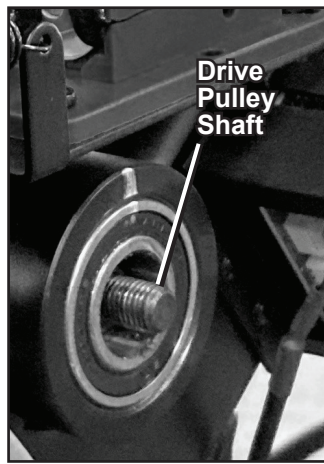
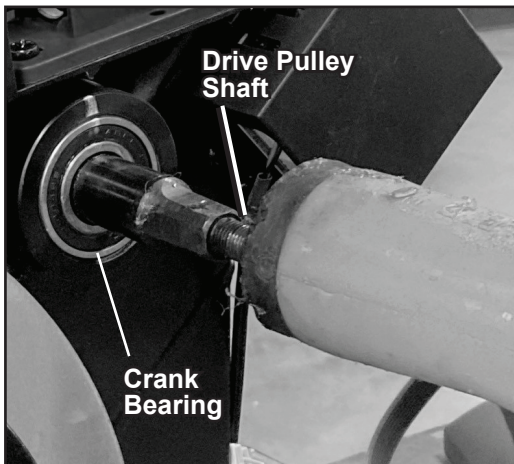

31. Push a new Snap Ring into position on the Drive Pulley Axle of the new Drive Pulley Assembly.

NOTICE: Make sure the Snap Ring is firmly seated on the Drive Pulley Axle.

Snap ring seated on inner drive pulley axle

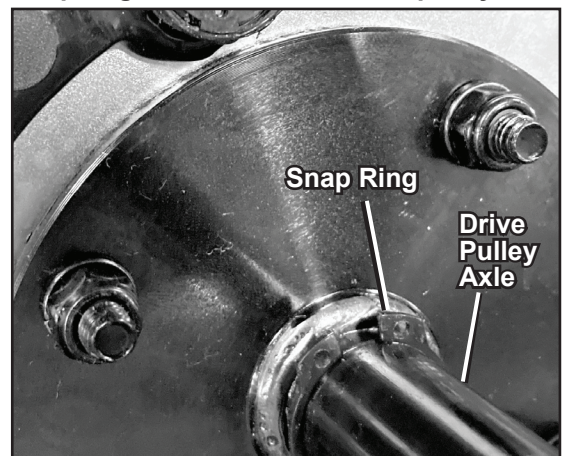

32. Installation is the reverse procedure. Align the Axle of the new Drive Pulley assembly with the mount hole on the Left side of the Frame. Using eye protection and a dead blow hammer, gently tap the end of the Pulley Shaft to push it into position.

Left side — Align drive pulley axle with mount hole in frame

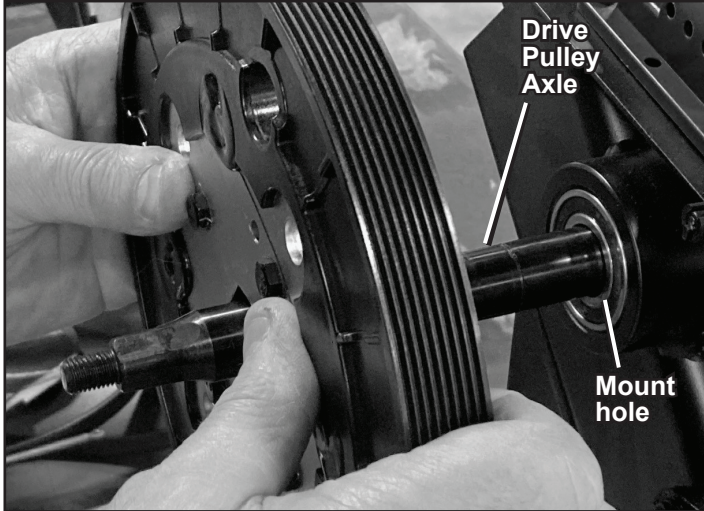

Gently tap the drive pulley shaft into position

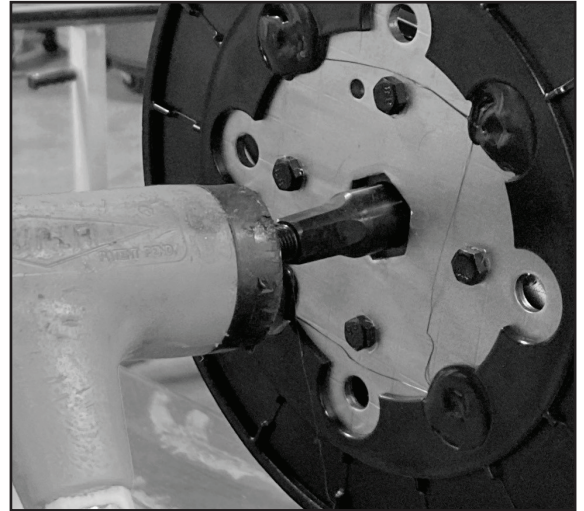

33. On the Right side of the machine, slide the Washer onto the Pulley Shaft. Using snap ring pliers, push the new Snap Ring into position to secure the Washer on the Pulley Shaft Assembly.

NOTICE: Make sure the Snap Ring is firmly seated on the Pulley Shaft Assembly.

Right side

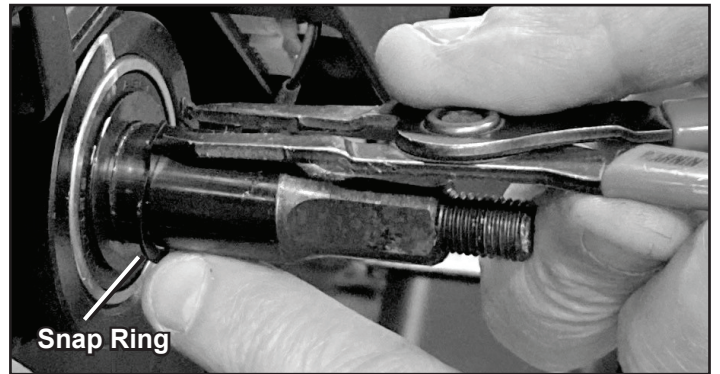
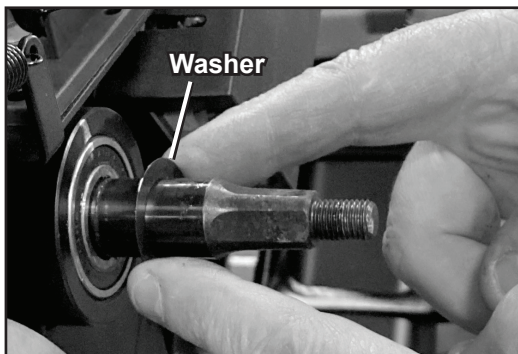

34. Put the Drive Belt in position on the Flywheel Pulley. Put the Drive Belt in position around the Tensioner Assembly. Be sure that the lower portion of the Drive Belt is above the Tensioner bearings on the Tensioner Assembly. Slowly turn the Drive Pulley backward and carefully ease the Drive Belt onto the Drive Pulley.

NOTICE: Be sure not to pinch or cut any cables.

35. Make sure the Drive Belt is aligned on the Flywheel Pulley, Belt Tensioner and Drive Pulley.

36. Using a 13mm wrench, tighten the Tensioner Nut the number of turns recorded to remove the Drive Belt.

37. Re-install all remaining parts that were removed in reverse order.

Installation of the Crank Arm does not require the use of the crank puller.

38. Final Inspection

Inspect your machine to ensure that all hardware is tight and components are properly assembled.



Do not use until the machine has been fully assembled and inspected for correct performance in accordance with the Owner's Manual.

NOTICE: This document provides instructions for the replacement of the Idler (Tensioner) Assembly on the Schwinn™ 490 / 590e Ellipticals.

If you need assistance, please contact Customer Service (if purchased in US/Canada) or your local distributor (if purchased outside US/Canada). To find your local distributor, go to: www.nautilusinternational.com

⚠ This icon means a potentially hazardous situation which, if not avoided, could result in death or serious injury. Read and understand all Warnings on this machine.

Nautilus, Inc., www.nautilus.com, 5415 Centerpoint Parkway, Groveport, OH 43125 U.S.A. - Customer Service: North America (800) 605-3369, csnls@nautilus.com | outside U.S. www.nautilusinternational.com | Printed in China | © 2023 Nautilus, Inc. | Schwinn and the Schwinn logo are trademarks owned or licensed by Nautilus, Inc., registered or otherwise protected by common law in the United States and other nations. | **ORIGINAL DOCUMENT - ENGLISH VERSION ONLY**

Important Safety Instructions - Before servicing or using this equipment, obey the following warnings:







⚠ This icon means a potentially hazardous situation which, if not avoided, could result in death or serious injury. Read and understand all Warnings on this machine.

⚠ DANGER To reduce the risk of electrical shock or unsupervised usage of the equipment, always unplug the power cord from the wall outlet and wait 5 minutes before cleaning, maintaining or repairing this machine. Place the power cord in a secure location.

- Read and understand the Part Replacement Procedure before working on the machine. Failure to obey the instructions and safety warnings could cause injury to the service technician or bystanders.
- Keep bystanders and children away from the product being serviced at all times.
- Disconnect all power to the machine before you service it.
- Make sure that the repair is done in an appropriate work space away from foot traffic and exposure to bystanders.
- Some components of the equipment can be heavy or awkward. Enlist the service of a second person when you do maintenance steps involving these components. Do not try to do heavy or awkward steps on your own.
- Use only replacement parts and hardware that are supplied or approved by Nautilus. Failure to use Nautilus-approved replacement parts can adversely affect the safety and functionality of the equipment creating a risk to users and will void the warranty.
- Be sure that all warning stickers and instructional placards applied to the product stay present and in good condition when doing maintenance or replacing components. If at any time the Warning labels become loose, unreadable or dislodged, replace the labels. If purchased in US/Canada, contact Customer Service for replacement labels. If purchased outside US/Canada, contact your local distributor for them.
- Do not try to change the design or functionality of the machine being serviced as this can adversely affect user safety.
- Do not use the machine until all shrouds, instructions, warning labels and correct functionality have been verified and tested for correct performance.

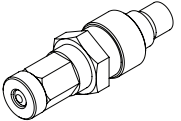
• SAVE THESE INSTRUCTIONS

Tools Required (not included)

#2 Phillips screwdriver		Snap ring pliers		Crank puller	
Small flathead screwdriver		Adjustable wrench			
14 mm Socket and wrench		Piece of string or wire, about 60 cm (24 inches) long			
		Safety goggles or other eye protection			

⚠ DANGER

To reduce the risk of electrical shock or unsupervised usage of the equipment, always unplug the power cord from the wall outlet and wait 5 minutes before cleaning, maintaining or repairing this machine. Place the power cord in a secure location.

Note: Your machine may not match the images provided exactly.

1. Unplug the Power Cord from the wall outlet and machine.

2. Flex the edges of the Front Lower Shroud to disengage the 8 inside tabs from the Main Shrouds.

Note: It may be easier to pry up the edges of the Front Lower Shroud using a flathead screwdriver. To avoid damage to the surface of the Shrouds, we recommend putting a piece of cloth over the screwdriver blade.



3. Flex the edges of the Front Upper Shroud to disengage the 4 inside tabs (2 on each side) from the Main Shrouds.



4. Using a #2 Phillips screwdriver, remove the 4 screws (2 indicated on this side of the machine by ovals) from the Rear Shroud.

5. Gently pivot the Rear Shroud down along the Incline (Lift) Motor Arm.



6. Gently compress the left Exterior Handlebar Cover to release it from the left Interior Handlebar Cover. There are five tabs that snap to secure each Cover.



7. Using a #2 Phillips screwdriver, remove the two screws that attach the Left Interior Handlebar Cover to the Handlebars. Set the hardware safely aside for reassembly.



8. Using a 6mm hex wrench, remove the four screws that attach the Left Upper Handlebar to the Left Lower Handlebar.

9. Slightly pull the Left Upper Handlebar out of the Left Lower Handlebar, and disconnect the cables. Set the Left Upper Handlebar and hardware safely aside.

NOTICE: Do not cut or pinch the cables. Do not let the cable fall down into the Left Lower Handlebar. This step may require two people.

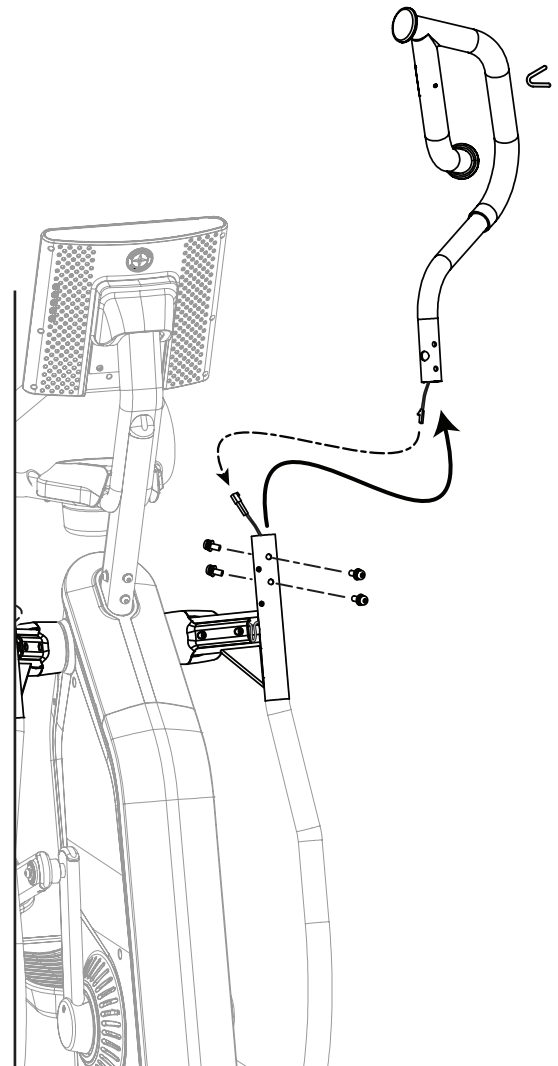

10. Using a 6mm hex wrench, remove the hardware (indicated by ovals) that attaches the Left Pedal and remove it.



Note: To assist with re-assembly, notice that the Pivot Pin is flush with the outside of the Lower Handlebar.



There is also a Wave Washer on the post from the Pedal.

Note: With the Pedal removed, do not fully rotate the Left Lower Handlebar or damage to the cables in the Handlebars will occur.

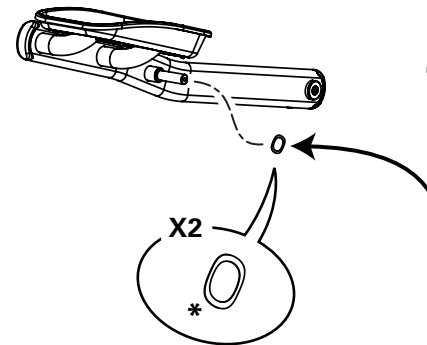

11. Using a 6mm hex wrench, remove the hardware (indicated by an oval) from the Left Leg and remove it.

Note: To assist with re-assembly, notice there is a Wave Washer on the post from the Crank Arm.



12. Using a #2 Phillips screwdriver, remove the indicated screw from the Crank Cap Shroud from the Crank Arm.



13. Using a 14mm wrench and socket, remove the Hex Nut from the Crank Arm.



Note: Your machine may not match the following images exactly.

14. Thread the Crank Puller into the Crank Arm (B). When the Crank Puller is in the correct position, only 1-2 threads on the outer portion (CP2) of the Crank Puller should show.

Note: Be sure the end of the Bolt (CP1) of the Crank Puller is flush with the Nut (CP2) as shown, before use.

Crank puller nut and inner bolt

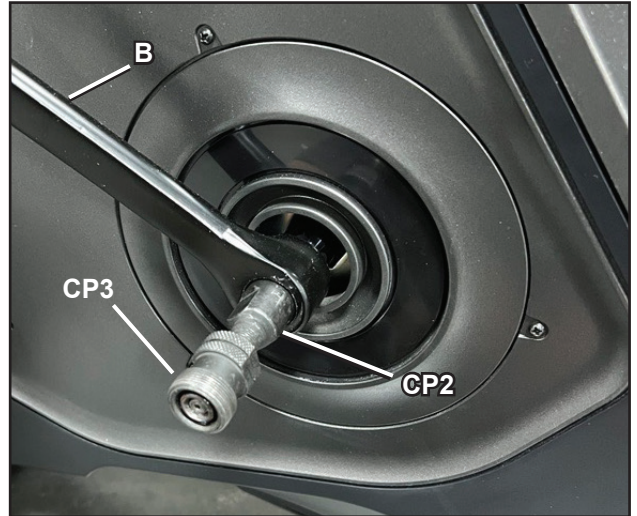
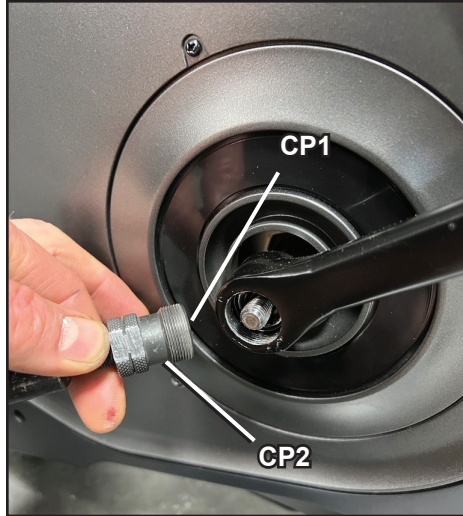

15. Using a wrench, turn the inner portion (CP3) of the Crank Puller clockwise. The Crank Arm (B) will slide off as it is tightened.

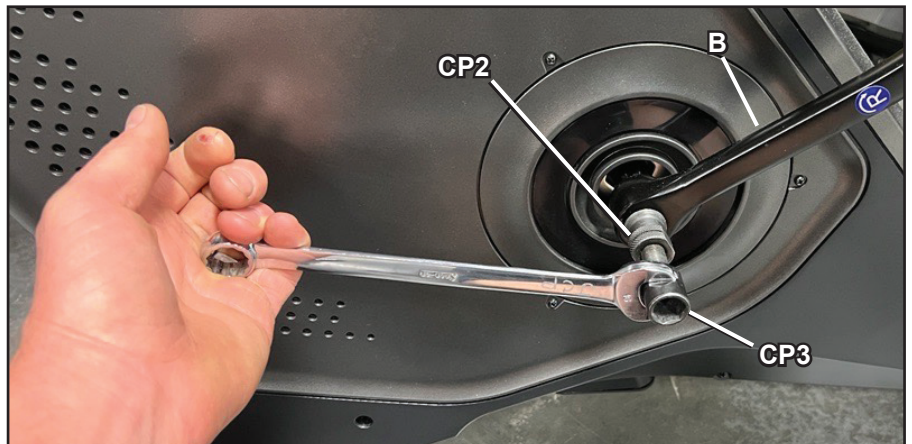

16. Gently compress the sides of the Pivot Cap to release it from the Inner Pivot Shroud.

17. Using a #2 Phillips screwdriver, remove the 2 screws from the Inner Pivot Shroud.

18. Tie a 60 cm (24 inch) long piece of wire or string to the end of the Cable. This wire or string will be used to pull the new cable through and out of the Lower Handlebar.

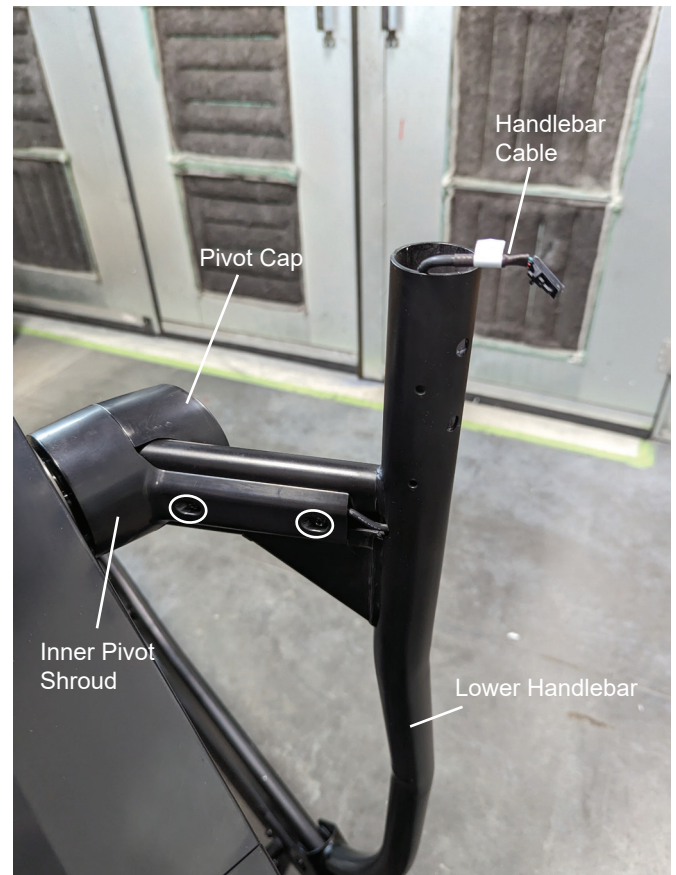

19. Using a 6mm hex wrench, remove the hardware (indicated by oval) that secures the Lower Handlebar.

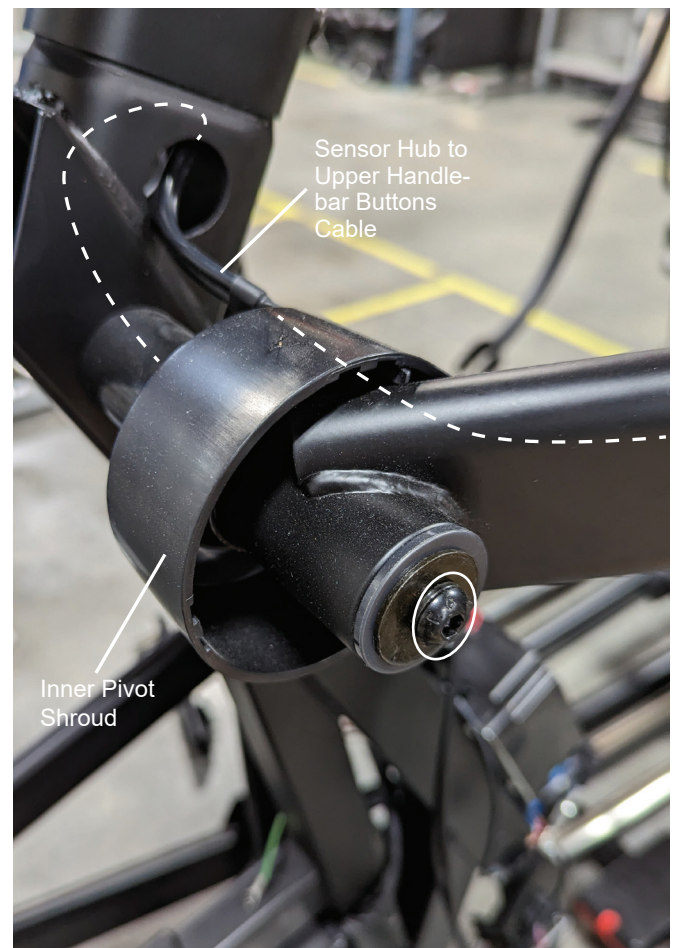

20. Slide the Lower Handlebar outward only about 1 inch (2.5 cm) from the machine.

21. Push the Inner Pivot Shroud toward the machine, off of the Lower Handlebar. This will release the Cable from the clips on the Inner Pivot Shroud.

22. With the wire or string still attached to the end of the Cable, pull the Cable toward the machine out of the Lower Handlebar. Be sure not to pull the end of the wire or string into the Lower Handlebar.

23. Remove the wire or string from the Cable, and tie the wire or string off at both ends of the Lower Handlebar. This will be used to route the Cable back through the Lower Handlebar.

24. Fully remove the Lower Handlebar from the Pivot Rod.

25. Using a #2 Phillips screwdriver, remove the 4 screws (indicated by ovals) from the Right Main Shroud. These screws connect to the Left Main Shroud.

Note: The Upper Front Shroud may need to be lifted to access the upper screw for the Right Main Shroud.



Note: Crank Arm and Lower Handlebar have been removed, but are shown here.

26. Using a #2 Phillips screwdriver, remove the 3 screws from the Left Main Shroud. Remove the Left Main Shroud and place outside the work area.



Note: Crank Arm and Lower Handlebar have been removed, but are shown here.

27. Using a 13mm wrench, remove the Tensioner Nut from the Tensioner Bolt. Be sure to record the number of turns performed to the Tensioner Nut to remove it so it can be reset to that tension during re-assembly.

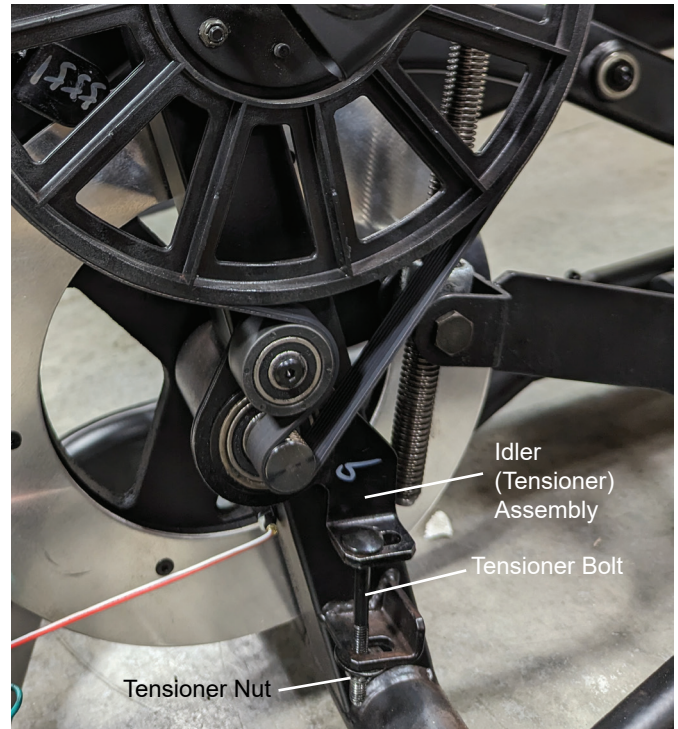

28. Remove the Drive Belt after noting how to properly route the Belt. Slowly turn the Drive Pulley backward and carefully ease the Drive Belt off the Drive Pulley to the outside.



Be sure to keep fingers clear of all pinch hazards as you turn the Drive Pulley.

NOTICE: Be sure not to pinch or cut any cables.



29. Using Retaining Ring Pliers, remove the retaining ring from the post that secures the old Idler (Tensioner) Assembly.

30. Carefully pull the old Idler (Tensioner) Assembly off of the post on the Main Frame.

31. Slide the new Idler (Tensioner) Assembly into position. Be sure the pivot hole in the Tensioner assembly engages the post.

32. Replace the Retaining Ring to secure the new Idler (Tensioner) Assembly to the Frame.

33. Put the Drive Belt in position on the Flywheel Pulley. Put the Drive Belt in position around the Tensioner Assembly. Be sure that the lower portion of the Drive Belt is above the Tensioner bearings on the Tensioner Assembly. Slowly turn the Drive Pulley backward and carefully ease the Drive Belt onto the Drive Pulley.

NOTICE: Be sure not to pinch or cut any cables.

34. Make sure the Drive Belt is aligned on the Flywheel Pulley, Belt Tensioner and Drive Pulley.

35. Using a 13mm wrench, tighten the Tensioner Nut the number of turns recorded to remove the Drive Belt.

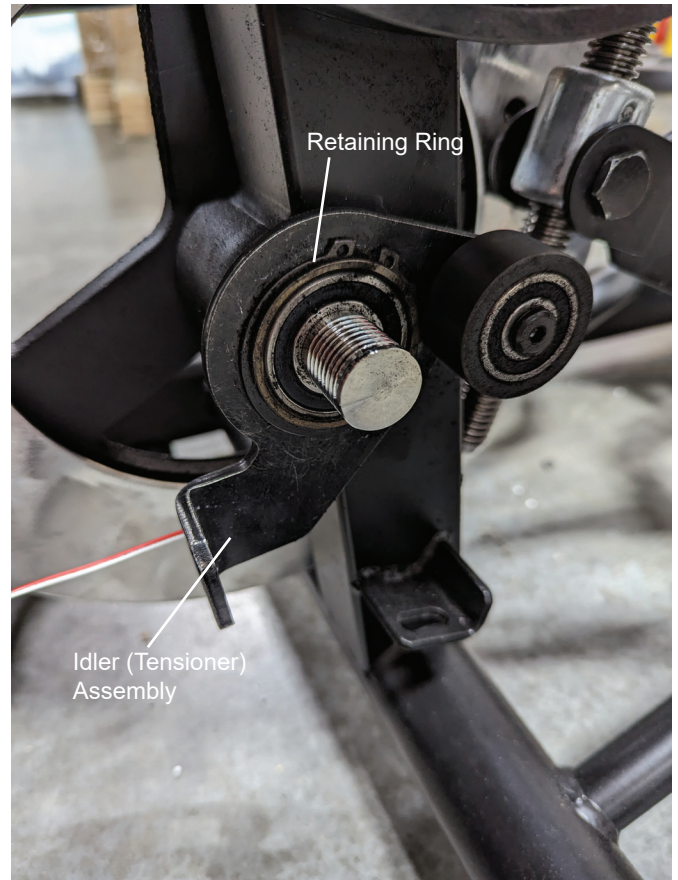

36. Re-install all remaining parts that were removed in reverse order.

37. Final Inspection

Inspect your machine to ensure that all hardware is tight and components are properly assembled.



Do not use until the machine has been fully assembled and inspected for correct performance in accordance with the Owner's Manual.

NOTICE: This document provides instructions for the replacement of the Incline (Lift) Motor Assembly on the Schwinn™ 490 / 590e Ellipticals.

If you need assistance, please contact Customer Service (if purchased in US/Canada) or your local distributor (if purchased outside US/Canada). To find your local distributor, go to: www.nautilusinternational.com

⚠ This icon means a potentially hazardous situation which, if not avoided, could result in death or serious injury. Read and understand all Warnings on this machine.

Nautilus, Inc., www.nautilus.com, 5415 Centerpoint Parkway, Groveport, OH 43125 U.S.A. - Customer Service: North America (800) 605-3369, csnls@nautilus.com | outside U.S. www.nautilusinternational.com | Printed in China | © 2023 Nautilus, Inc. | Schwinn and the Schwinn logo are trademarks owned or licensed by Nautilus, Inc., registered or otherwise protected by common law in the United States and other nations. | **ORIGINAL DOCUMENT - ENGLISH VERSION ONLY**

Important Safety Instructions - Before servicing or using this equipment, obey the following warnings:

⚠ This icon means a potentially hazardous situation which, if not avoided, could result in death or serious injury. Read and understand all Warnings on this machine.

⚠ DANGER To reduce the risk of electrical shock or unsupervised usage of the equipment, always unplug the power cord from the wall outlet and wait 5 minutes before cleaning, maintaining or repairing this machine. Place the power cord in a secure location.

- Read and understand the Part Replacement Procedure before working on the machine. Failure to obey the instructions and safety warnings could cause injury to the service technician or bystanders.
- Keep bystanders and children away from the product being serviced at all times.
- Disconnect all power to the machine before you service it.
- Make sure that the repair is done in an appropriate work space away from foot traffic and exposure to bystanders.
- Some components of the equipment can be heavy or awkward. Enlist the service of a second person when you do maintenance steps involving these components. Do not try to do heavy or awkward steps on your own.
- Use only replacement parts and hardware that are supplied or approved by Nautilus. Failure to use Nautilus-approved replacement parts can adversely affect the safety and functionality of the equipment creating a risk to users and will void the warranty.
- Be sure that all warning stickers and instructional placards applied to the product stay present and in good condition when doing maintenance or replacing components. If at any time the Warning labels become loose, unreadable or dislodged, replace the labels. If purchased in US/Canada, contact Customer Service for replacement labels. If purchased outside US/Canada, contact your local distributor for them.
- Do not try to change the design or functionality of the machine being serviced as this can adversely affect user safety.
- Do not use the machine until all shrouds, instructions, warning labels and correct functionality have been verified and tested for correct performance.

• SAVE THESE INSTRUCTIONS

Tools Required (not included)

#2 Phillips screwdriver

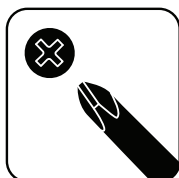

13mm wrench
17mm wrench
18mm wrench
19mm wrench



Standard screwdriver



6mm hex wrench

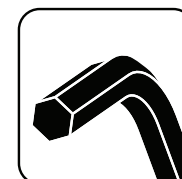

Measuring tape or ruler



⚠ DANGER

To reduce the risk of electrical shock or unsupervised usage of the equipment, always unplug the power cord from the wall outlet and wait 5 minutes before cleaning, maintaining or repairing this machine. Place the power cord in a secure location.

Note: Your machine may not match the images provided exactly.

1. Unplug the Power Cord from the wall outlet and machine.

2. Flex the edges of the Front Lower Shroud to disengage the 8 inside tabs from the Main Shrouds.

Note: It may be easier to pry up the edges of the Front Lower Shroud using a flathead screwdriver. To avoid damage to the surface of the Shrouds, we recommend putting a piece of cloth over the screwdriver blade.



Note: The Shrouds have been removed from some of the images to provide additional details.

3. Using a 6mm hex wrench, remove the 4 screws (indicated by ovals) that attach the Offline Power Supply Cover.



Note: Main Shrouds removed for clarity.

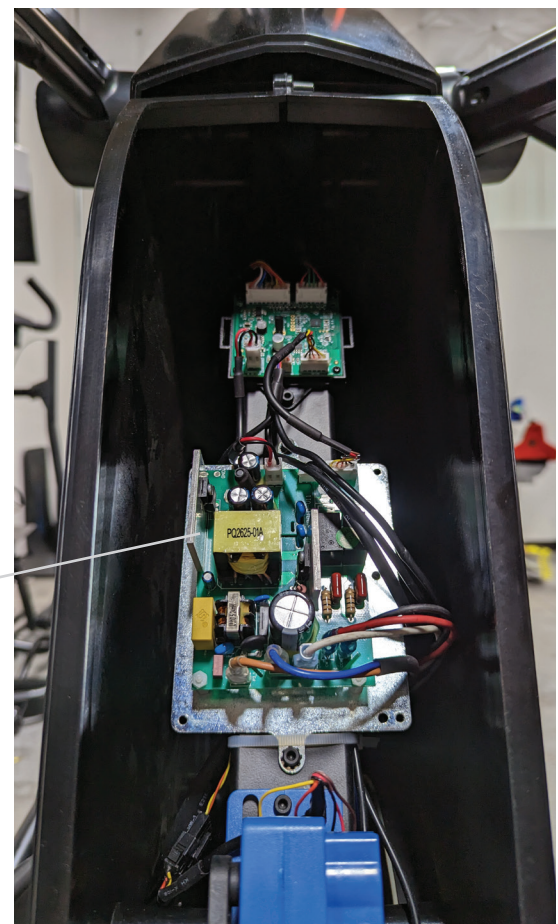
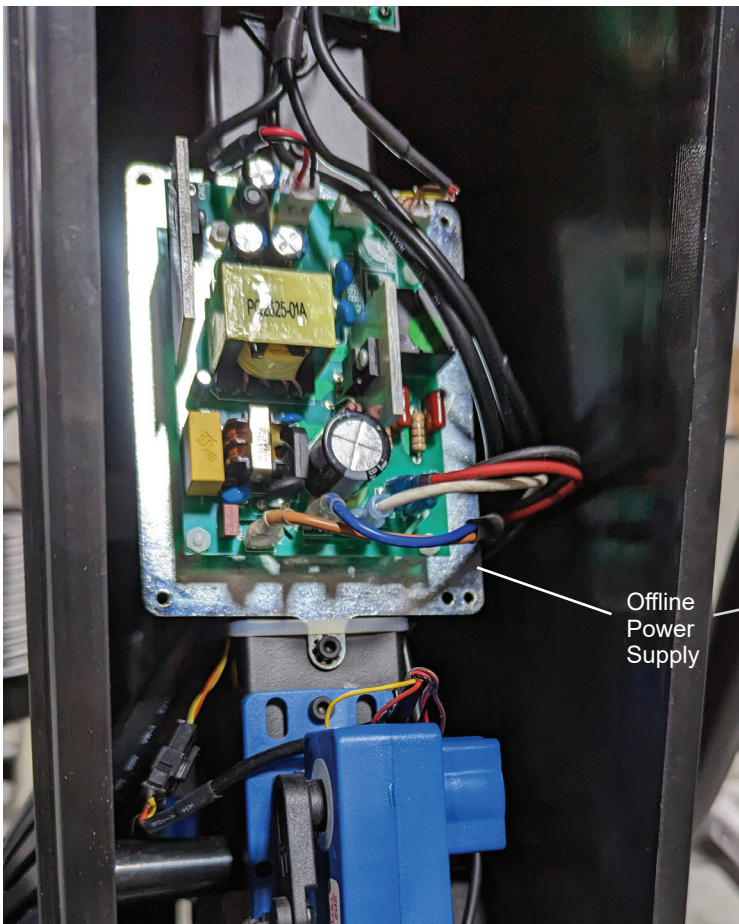

4. Remove the 4 connectors from the Offline Power Supply for the Lift Motor after noting their locations.

Note: Be sure to note where all cables attach for re-assembly. Do not let the cables fall into the machine.

NOTICE: Do not cut or pinch the cables.

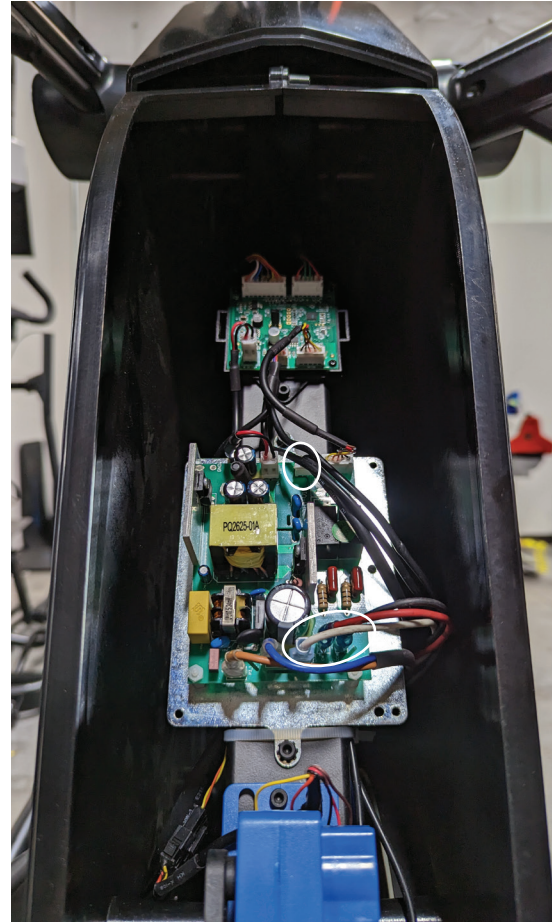

ELECTRICAL WIRING ROUTE DETAIL

- Incline (Lift) Motor Assembly

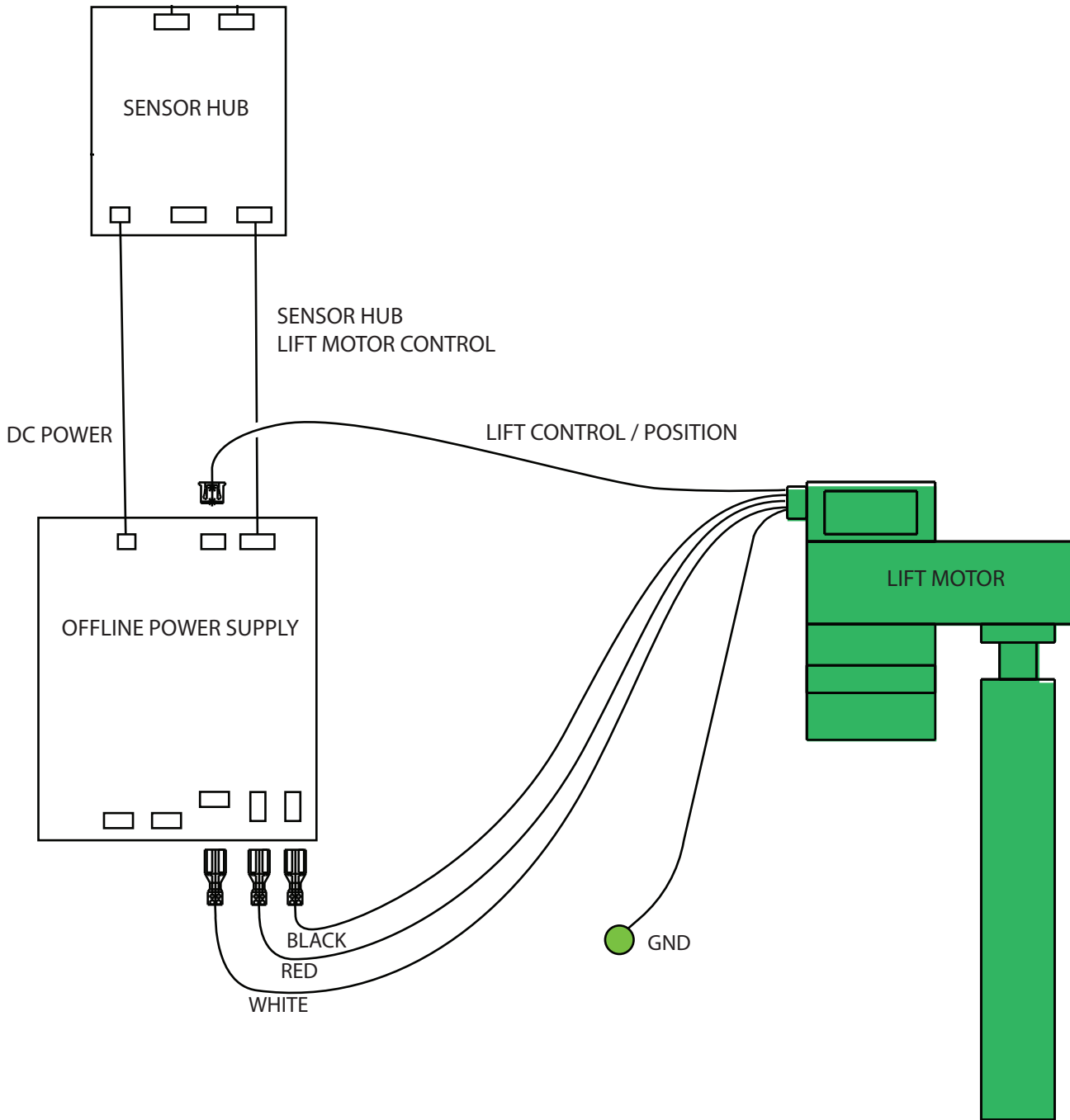

5. Using 6mm hex wrench and a 13mm open faced wrench, remove the hardware (indicated by ovals) that attaches the Rail Assembly and the Incline (Lift) Motor Arm.

6. Slide the Incline (Lift) Motor Arm from the Rail Assembly.

⚠ In order to avoid possible serious injury, when the Rail Assembly has been released from the Main Assembly, be careful to avoid fingers or hands being caught or pinched. Do not place fingers or hands below any pivoting parts of the Rail Assembly.

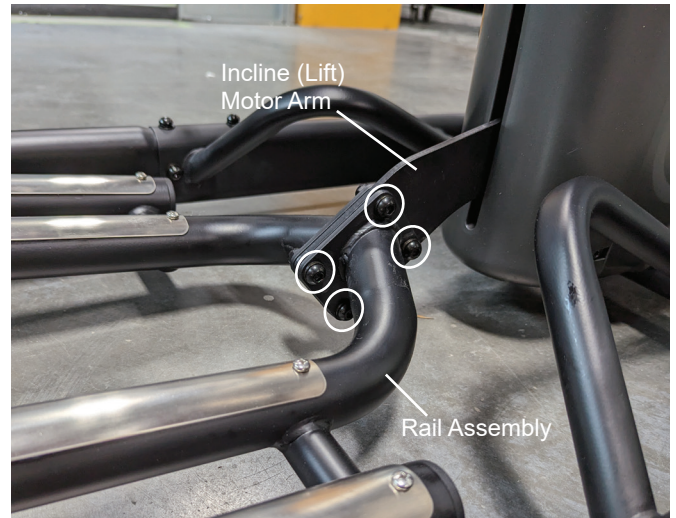

7. Using a #2 Phillips screwdriver, remove the 4 screws (2 indicated on this side of the machine by ovals) from the Rear Shroud.

8. Gently pivot the Rear Shroud down along the Incline (Lift) Motor Arm and remove it.



Note: The Shrouds have been removed from some of the images to provide additional details.

9. Using a 17mm and an 18mm open faced wrench, remove the hardware (indicated by ovals) that secures the Incline Lift Motor to the Frame. Be prepared to support the Incline Lift Motor when released.

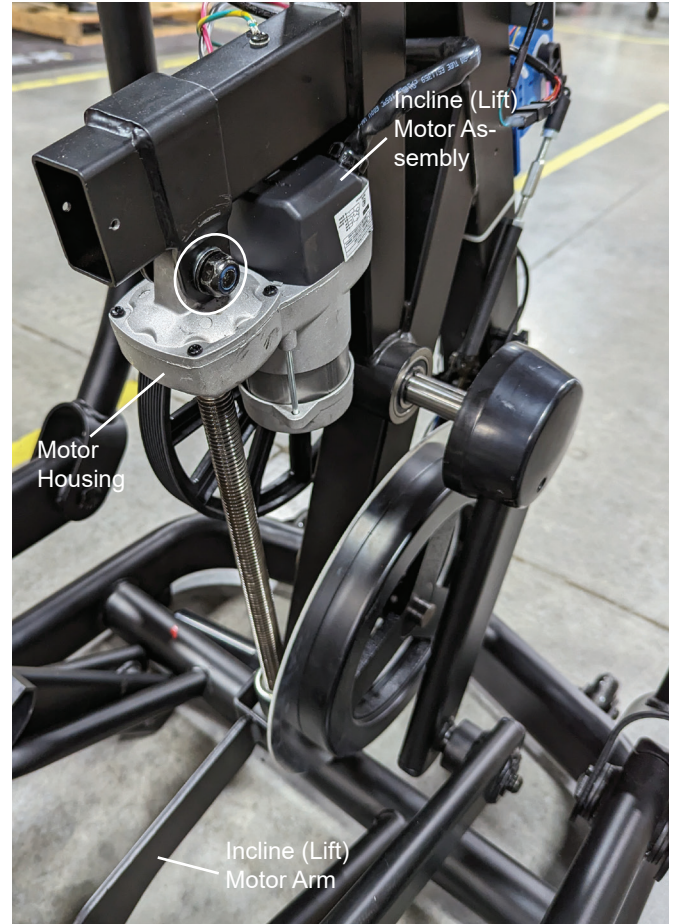

10. Using a 19mm open end wrench, loosen and remove the hex head bolts that attach the Incline Adjuster Assembly to the Incline (Lift) Motor Arm. Set the bolts aside for reassembly.

11. Attach the new Incline Motor Assembly to the Frame, being sure that the cables are positioned appropriately.

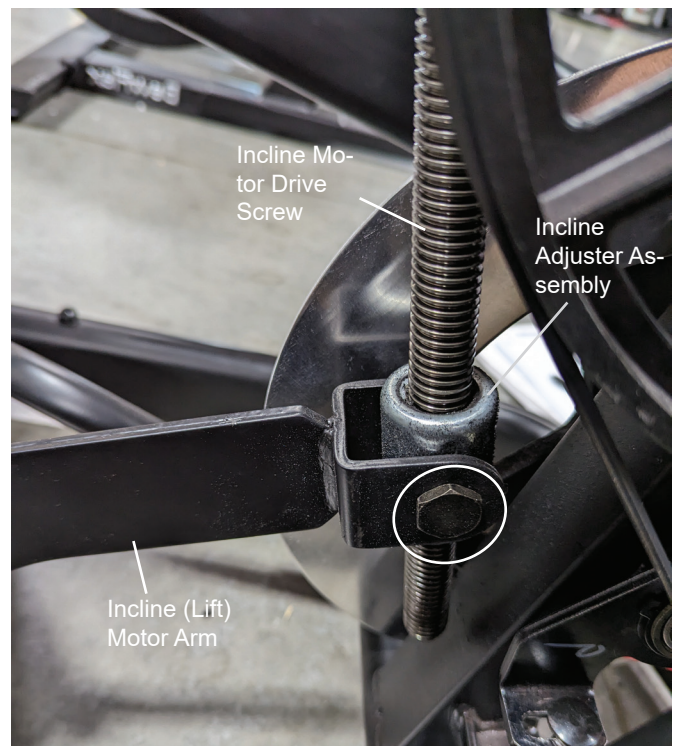

12. Route the cables from the new Incline Motor Assembly to the Offline Power Supply, and connect them in their proper locations. Be sure not to crimp any cables.

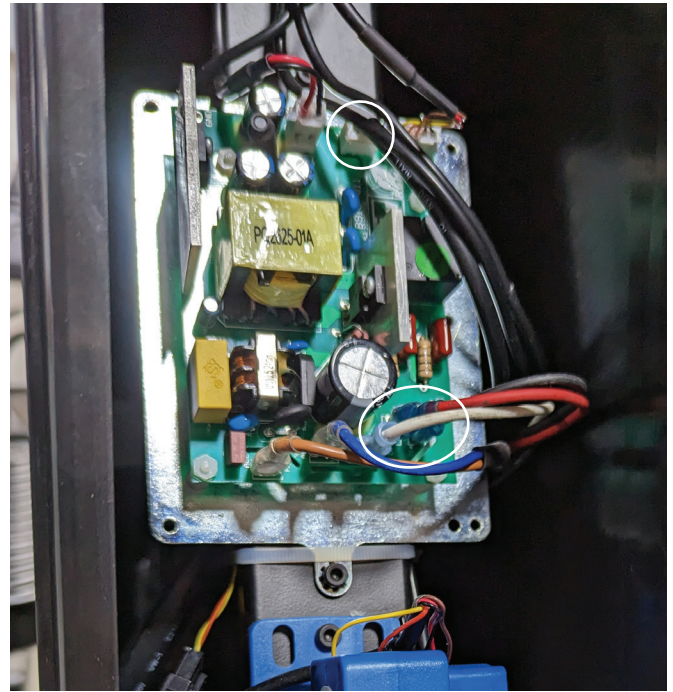

13. Adjust the Incline Adjuster Assembly to have a 15 - 20mm gap (2 - 3 exposed Drive Screw threads) from the Motor Housing.

14. Using a 19mm open end wrench, secure the Incline Adjuster Assembly to the Incline (Lift) Motor Arm.

15. Re-assemble the machine in the reverse order of when the parts were removed.

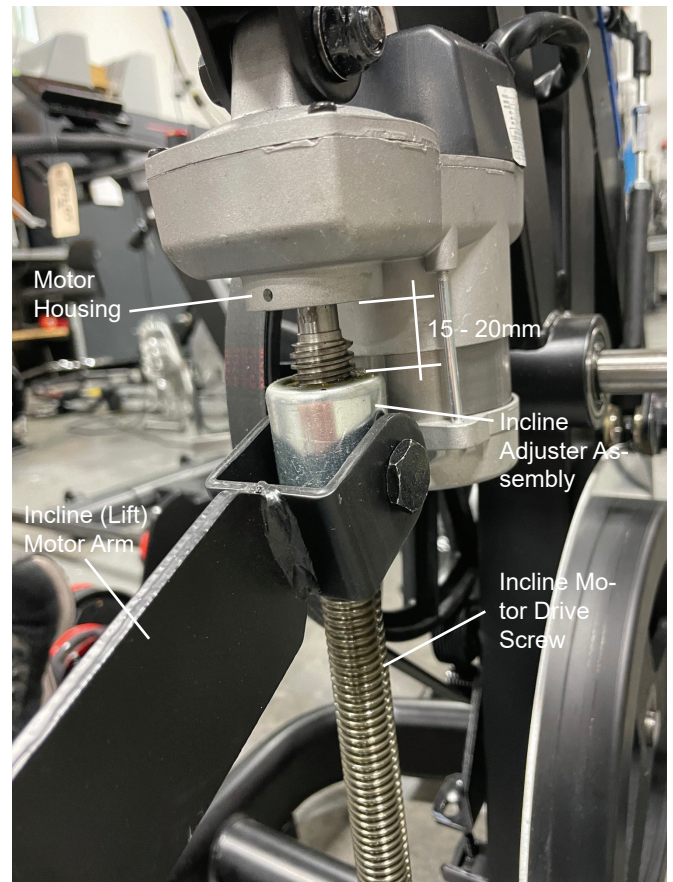

⚠ DANGER

The Offline Power Supply Cover **MUST** be re-installed before turning on the power. Hazardous voltages are present when power is supplied.

16. Plug the power cord into the machine and wall outlet, and flip the power switch to on.

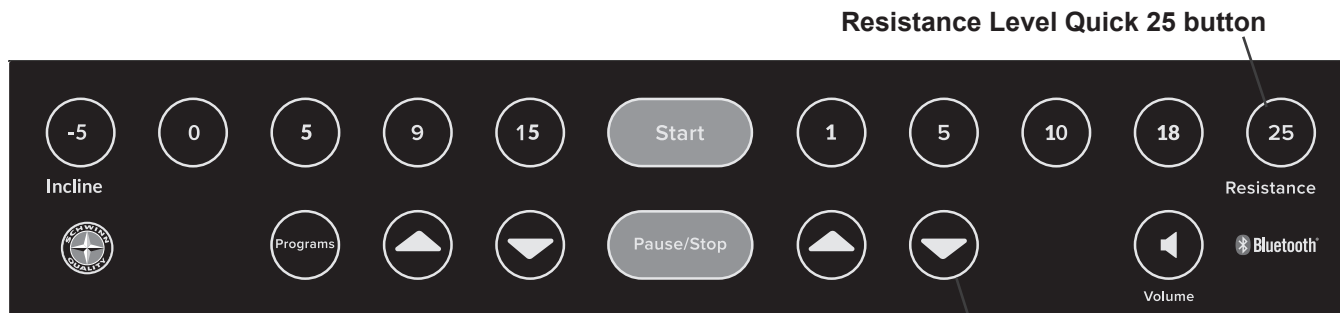

17. Push the Programs button and hold for 3 seconds while in the Power-Up Mode to go into the Console Setup Mode (System Menu).

Note: To exit the System Menu and return to the Power-Up Mode screen, push the Pause/Stop button.

18. The Console display shows the System Units prompt with the current setting. Tap the Programs button 4 times to advance through the System Menu.

19. The Console display shows the Hardware Variant & Console Firmware Version. The sample screen shows the format (values may be different).

Push and hold for 3 seconds the Resistance Level Quick 25 button to go to the Manufacturing Test Menu.

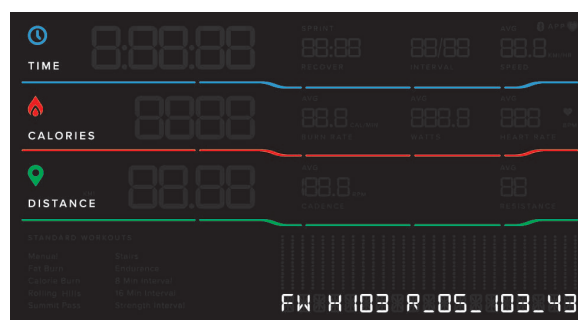

20. The Console display shows the START TEST SUITE menu option. Push the Resistance Decrease (▼) button 3 times to advance to the CAL_INCLINE option.

If the Start button was pushed instead of the Resistance Decrease (▼) button twice, turn the Power Switch to OFF and return to Step 1.

If the Resistance Decrease (▼) button was pushed more than 3 times going past the CAL_INCLINE option, push the Resistance Increase (▲) button to return to the CAL_INCLINE option.



21. The Console display shows the CAL_INCLINE option. Push the Start button.

Note: If the Pause/Stop button is pushed part way through the calibration (exit), the new calibration is not saved.



22. The console will display changing text and numbers for approximately 30 seconds as the incline motor fully raises the Pedals, then fully lowers the Pedals, and then brings the Pedals to the level or “0” setting.

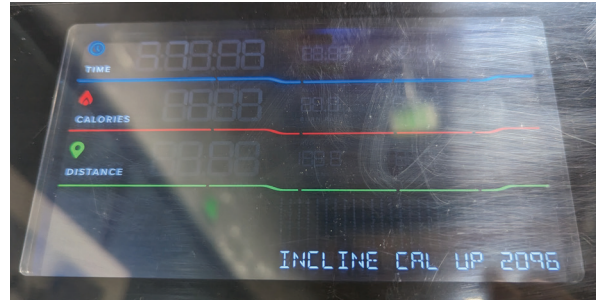

23. The console display will change to “CNFRM AT LVL 0 24XX”.

Note: The 0 incline level can be trimmed here for near perfect level position by using the Incline Increase (▲) and Incline Decrease (▼) buttons. If a finer level of adjustment is needed, use the Incline Level Quick 9 button to slightly increase, or the Incline Level Quick 15 button to slightly decrease.



24. Push the Start button to confirm and save the incline calibration values. The display will momentarily change to “SAVE ZERO LVL:24XX”, then display “CAL_INCLINE”. Calibration is complete.

Note: Pushing the Pause/Stop button will abort the calibration process, with the new calibration values not being saved, and the last saved calibration values being restored.

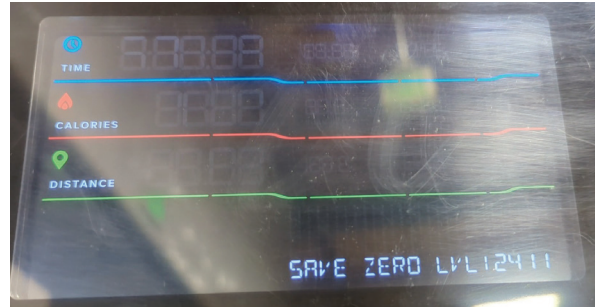

25. Power off the machine.

26. Power on the machine. After the Power-Up/Welcome screen appears, use the Incline Level Quick keys 15 and -5 to confirm that the incline moves properly between incline level -5 and 15.

27. Final Inspection

Inspect your machine to ensure that all hardware is tight and components are properly assembled.



Do not use until the machine has been fully assembled and inspected for correct performance in accordance with the Owner’s Manual.

NOTICE: This document provides instructions for the replacement of the Offline Power Supply on the Schwinn™ 490 / 590e Ellipticals.

If you need assistance, please contact Customer Service (if purchased in US/Canada) or your local distributor (if purchased outside US/Canada). To find your local distributor, go to: www.nautilusinternational.com

! This icon means a potentially hazardous situation which, if not avoided, could result in death or serious injury.
Read and understand all Warnings on this machine.

Nautilus, Inc., www.nautilus.com, 5415 Centerpoint Parkway, Groveport, OH 43125 U.S.A. - Customer Service: North America (800) 605-3369, csnls@nautilus.com | outside U.S. www.nautilusinternational.com | Printed in China | © 2023 Nautilus, Inc. | Schwinn and the Schwinn logo are trademarks owned or licensed by Nautilus, Inc., registered or otherwise protected by common law in the United States and other nations. | ORIGINAL DOCUMENT - ENGLISH VERSION ONLY

Important Safety Instructions - Before servicing or using this equipment, obey the following warnings:

! This icon means a potentially hazardous situation which, if not avoided, could result in death or serious injury.
Read and understand all Warnings on this machine.

DANGER

To reduce the risk of electrical shock or unsupervised usage of the equipment, always unplug the power cord from the wall outlet and wait 5 minutes before cleaning, maintaining or repairing this machine. Place the power cord in a secure location.

- Read and understand the Part Replacement Procedure before working on the machine. Failure to obey the instructions and safety warnings could cause injury to the service technician or bystanders.
- Keep bystanders and children away from the product being serviced at all times.
- Disconnect all power to the machine before you service it.
- Make sure that the repair is done in an appropriate work space away from foot traffic and exposure to bystanders.
- Some components of the equipment can be heavy or awkward. Enlist the service of a second person when you do maintenance steps involving these components. Do not try to do heavy or awkward steps on your own.
- Use only replacement parts and hardware that are supplied or approved by Nautilus. Failure to use Nautilus-approved replacement parts can adversely affect the safety and functionality of the equipment creating a risk to users and will void the warranty.
- Be sure that all warning stickers and instructional placards applied to the product stay present and in good condition when doing maintenance or replacing components. If at any time the Warning labels become loose, unreadable or dislodged, replace the labels. If purchased in US/Canada, contact Customer Service for replacement labels. If purchased outside US/Canada, contact your local distributor for them.
- Do not try to change the design or functionality of the machine being serviced as this can adversely affect user safety.
- Do not use the machine until all shrouds, instructions, warning labels and correct functionality have been verified and tested for correct performance.

• SAVE THESE INSTRUCTIONS

Tools Required (not included)

Standard screwdriver



Zip-Ties (Replacements)
Something to cut a Zip-Tie

6mm Hex wrench



⚠ DANGER

To reduce the risk of electrical shock or unsupervised usage of the equipment, always unplug the power cord from the wall outlet and wait 5 minutes before cleaning, maintaining or repairing this machine. Place the power cord in a secure location.

Note: Your machine may not match the images provided exactly.

1. Unplug the Power Cord from the wall outlet and machine.
2. Flex the edges of the Front Lower Shroud to disengage the 8 inside tabs from the Main Shrouds.

Note: It may be easier to pry up the edges of the Front Lower Shroud using a flathead screwdriver. To avoid damage to the surface of the Shrouds, we recommend putting a piece of cloth over the screwdriver blade.



Note: The Shrouds have been removed from some of the images to provide additional details.

3. Using a 6mm hex wrench, remove the 4 screws (indicated by ovals) that attach the Offline Power Supply Cover.

4. Remove the connectors from the Offline Power Supply after noting their locations.

Note: Be sure to note where all cables attach for re-assembly. Do not let the cables fall into the machine. If the Cable Connectors are secured by a small amount of glue, use a pair of small nose pliers to grab and remove the glue.

NOTICE: Do not cut or pinch the cables.



Note: Main Shrouds removed for clarity.

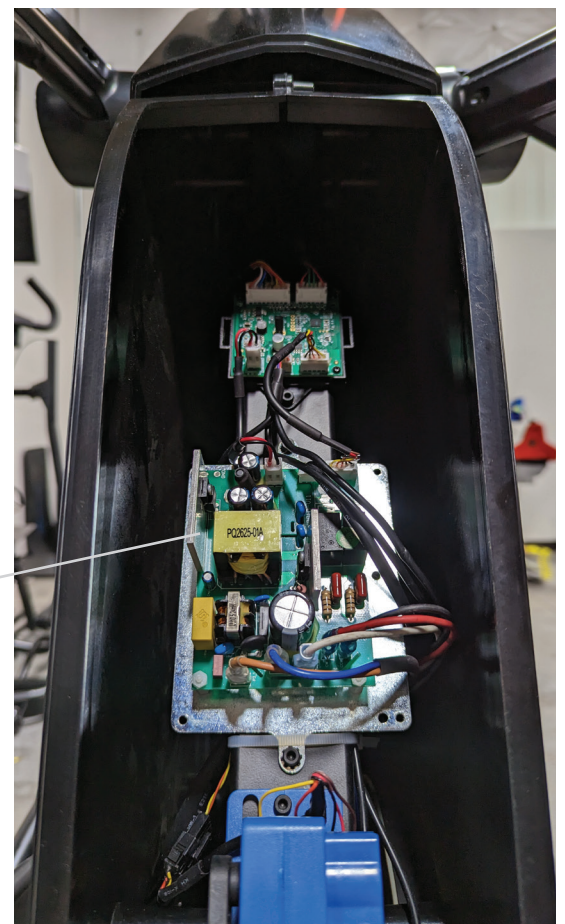
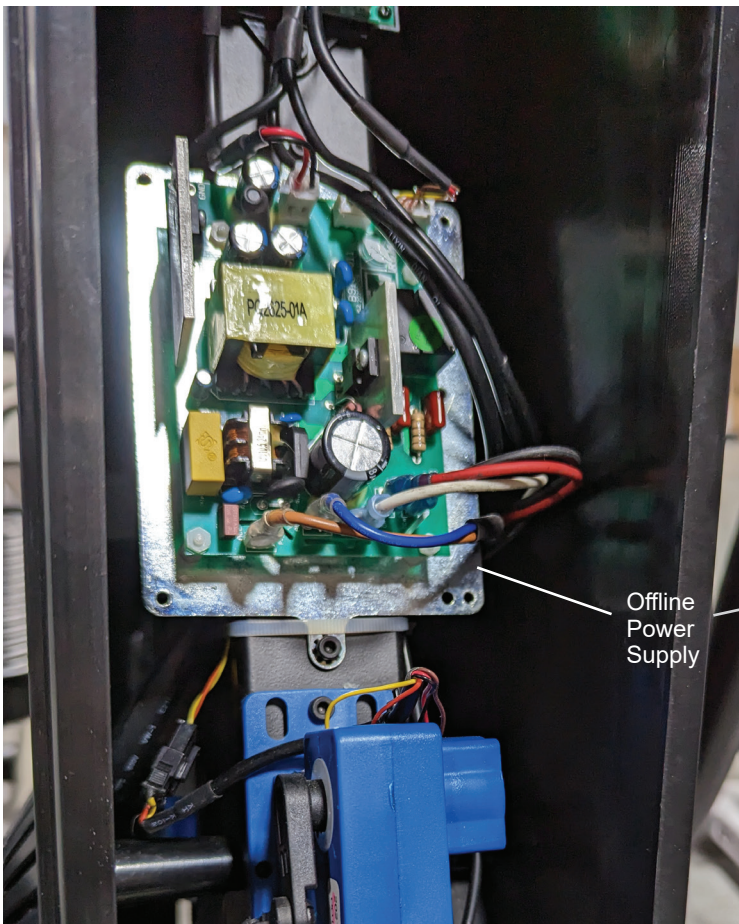

ELECTRICAL WIRING ROUTE DETAIL

- Offline Power Supply

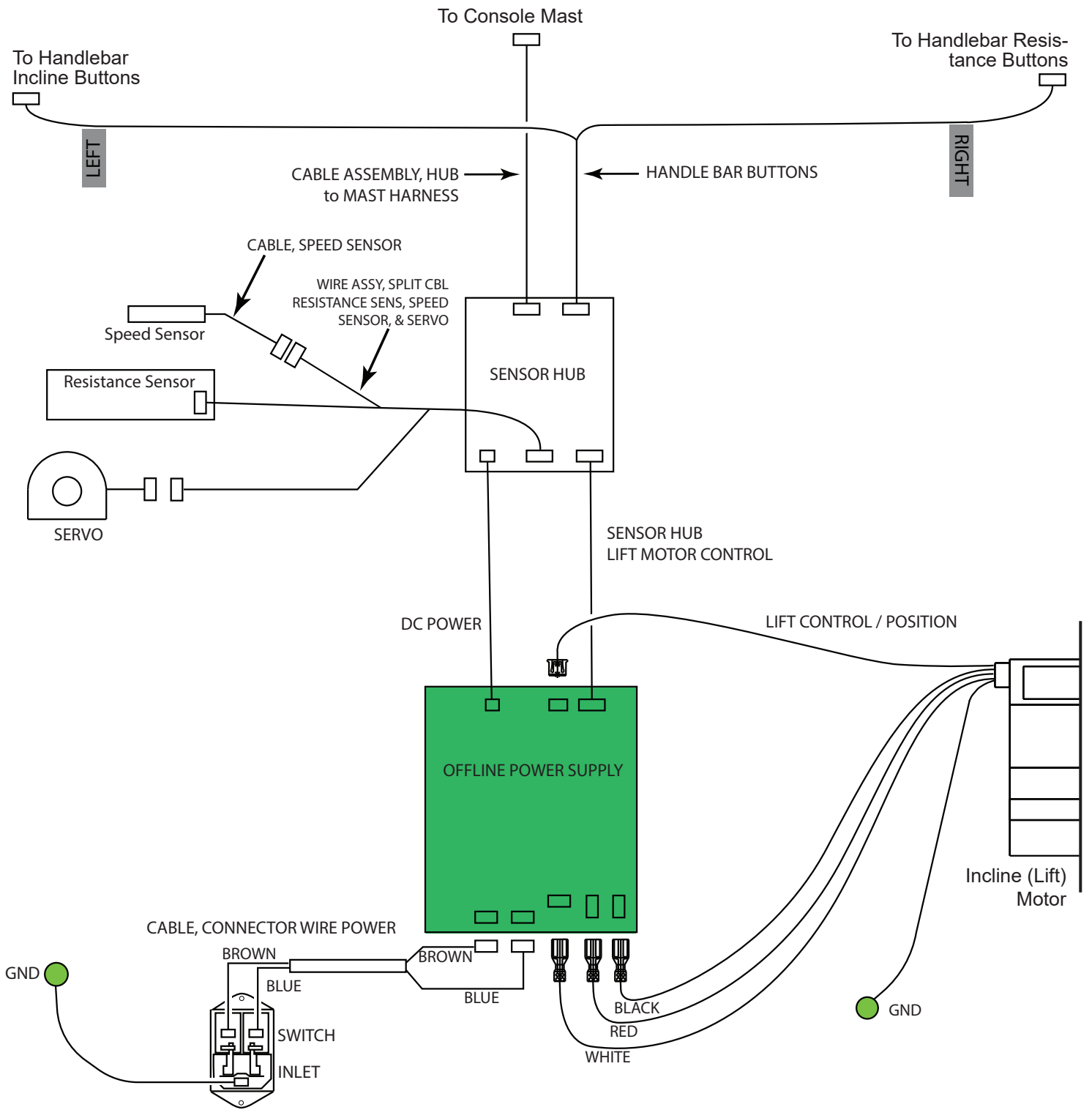

5. Using a 6mm hex wrench, remove the 2 screws (indicated by ovals) that attach the Offline Power Supply to the Frame.

6. Remove the old Offline Power Supply, and install the new Offline Power Supply. Connect all the cables to the Offline Power Supply in their proper locations. Be sure not to crimp any cables.

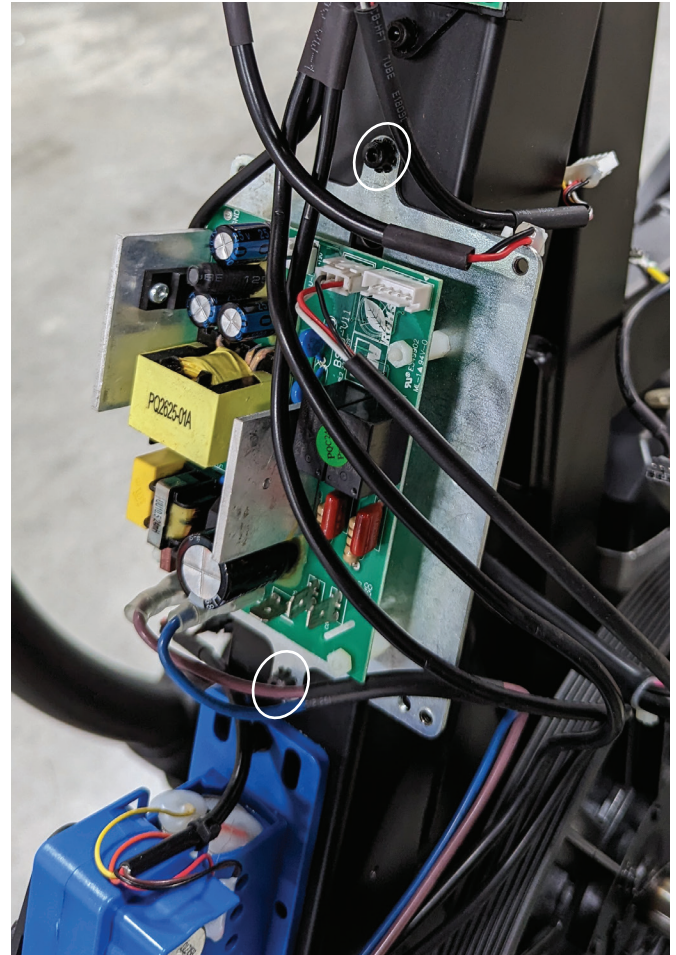

7. Re-install all remaining parts that were removed in reverse order.

8. Final Inspection

Inspect your machine to ensure that all hardware is tight and components are properly assembled.

⚠ Do not use until the machine has been fully assembled and inspected for correct performance in accordance with the Owner's Manual.

NOTICE: This document provides instructions for the replacement of the Resistance Sensor on the Schwinn™ 490 / 590e Ellipticals.

If you need assistance, please contact Customer Service (if purchased in US/Canada) or your local distributor (if purchased outside US/Canada). To find your local distributor, go to: www.nautilusinternational.com

⚠ This icon means a potentially hazardous situation which, if not avoided, could result in death or serious injury. Read and understand all Warnings on this machine.

Nautilus, Inc., www.nautilus.com, 5415 Centerpoint Parkway, Groveport, OH 43125 U.S.A. - Customer Service: North America (800) 605-3369, csnls@nautilus.com | outside U.S. www.nautilusinternational.com | Printed in China | © 2023 Nautilus, Inc. | Schwinn and the Schwinn logo are trademarks owned or licensed by Nautilus, Inc., registered or otherwise protected by common law in the United States and other nations. | **ORIGINAL DOCUMENT - ENGLISH VERSION ONLY**

Important Safety Instructions - Before servicing or using this equipment, obey the following warnings:

⚠ This icon means a potentially hazardous situation which, if not avoided, could result in death or serious injury. Read and understand all Warnings on this machine.

⚠ DANGER To reduce the risk of electrical shock or unsupervised usage of the equipment, always unplug the power cord from the wall outlet and wait 5 minutes before cleaning, maintaining or repairing this machine. Place the power cord in a secure location.

- Read and understand the Part Replacement Procedure before working on the machine. Failure to obey the instructions and safety warnings could cause injury to the service technician or bystanders.
- Keep bystanders and children away from the product being serviced at all times.
- Disconnect all power to the machine before you service it.
- Make sure that the repair is done in an appropriate work space away from foot traffic and exposure to bystanders.
- Some components of the equipment can be heavy or awkward. Enlist the service of a second person when you do maintenance steps involving these components. Do not try to do heavy or awkward steps on your own.
- Use only replacement parts and hardware that are supplied or approved by Nautilus. Failure to use Nautilus-approved replacement parts can adversely affect the safety and functionality of the equipment creating a risk to users and will void the warranty.
- Be sure that all warning stickers and instructional placards applied to the product stay present and in good condition when doing maintenance or replacing components. If at any time the Warning labels become loose, unreadable or dislodged, replace the labels. If purchased in US/Canada, contact Customer Service for replacement labels. If purchased outside US/Canada, contact your local distributor for them.
- Do not try to change the design or functionality of the machine being serviced as this can adversely affect user safety.
- Do not use the machine until all shrouds, instructions, warning labels and correct functionality have been verified and tested for correct performance.

• SAVE THESE INSTRUCTIONS

Tools Required (not included)

Short #2 Phillips screwdriver



⚠ DANGER

To reduce the risk of electrical shock or unsupervised usage of the equipment, always unplug the power cord from the wall outlet and wait 5 minutes before cleaning, maintaining or repairing this machine. Place the power cord in a secure location.

Note: Your machine may not match the images provided exactly.

1. Unplug the Power Cord from the wall outlet and machine.

2. Flex the edges of the Front Lower Shroud to disengage the 8 inside tabs from the Main Shrouds.

Note: It may be easier to pry up the edges of the Front Lower Shroud using a flathead screwdriver. To avoid damage to the surface of the Shrouds, we recommend putting a piece of cloth over the screwdriver blade.



3. Using a #2 Phillips screwdriver, remove the screw that secures the Right and Left Main Shrouds just above the exposed Flywheel.

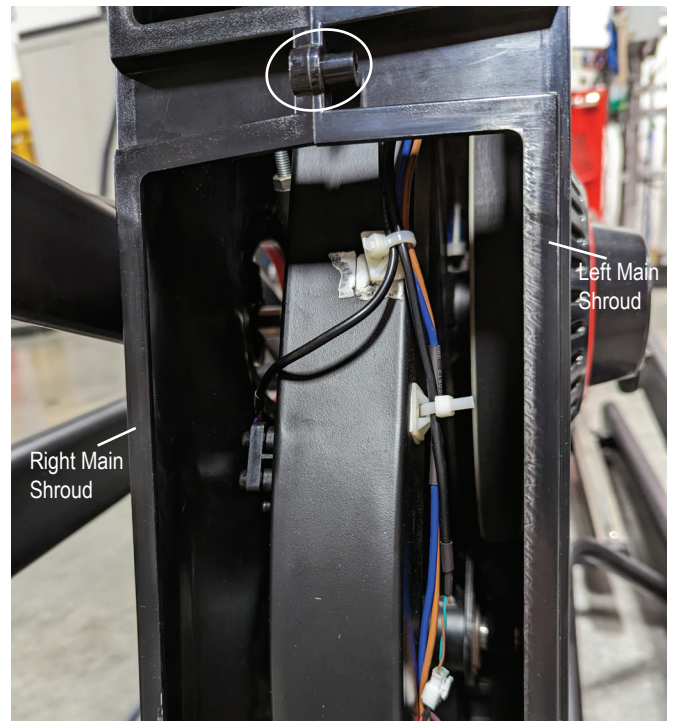

4. Using a #2 Phillips screwdriver, remove the screw (indicated by oval) that secures the Left Main Shroud to the Frame.



Note: The Resistance Sensor can be accessed by gently flexing the Right Main Shroud outward slightly. The Shrouds have been removed from the images to provide additional details.

5. Disconnect the Resistance Sensor Cable Connector from the Resistance Sensor.

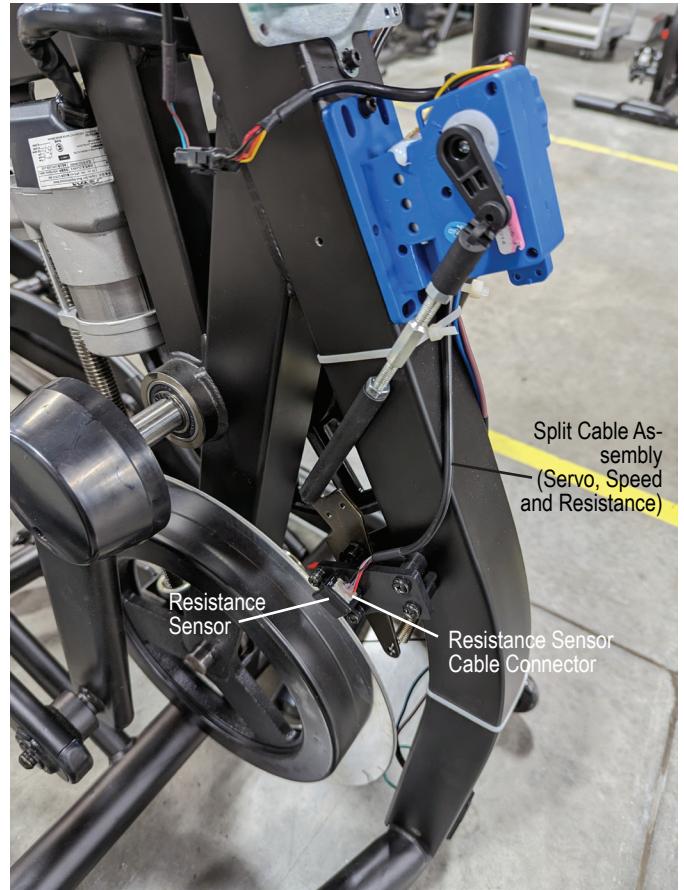

6. Using a #2 Phillips screwdriver, remove the two screws (indicated by ovals) that secures the Resistance Sensor.

7. Using a #2 Phillips screwdriver, connect the new Resistance Sensor to the Frame.

8. Connect the Resistance Sensor Cable Connector to the Resistance Sensor.

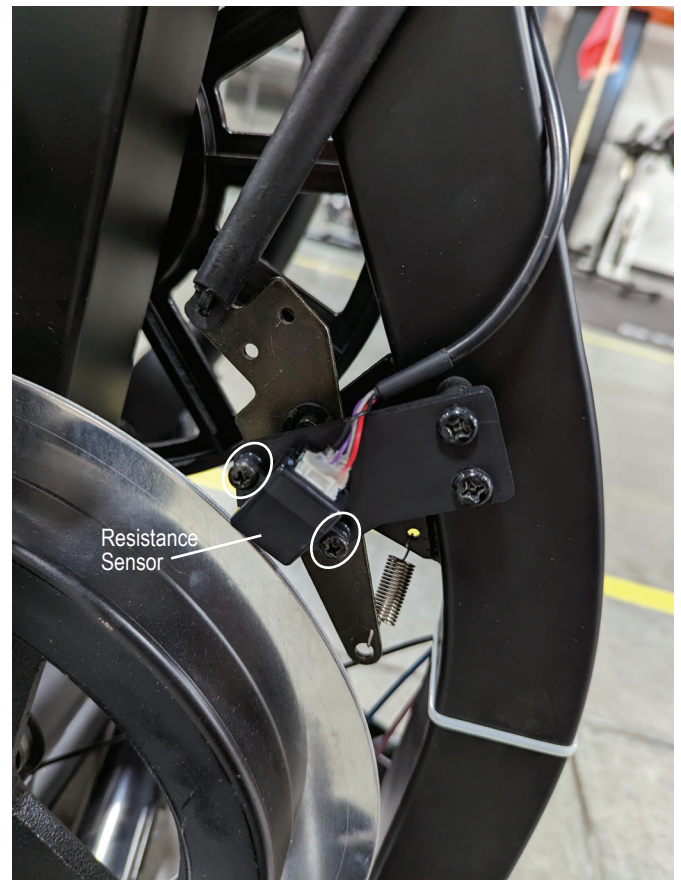

ELECTRICAL WIRING ROUTE DETAIL

- Resistance Sensor

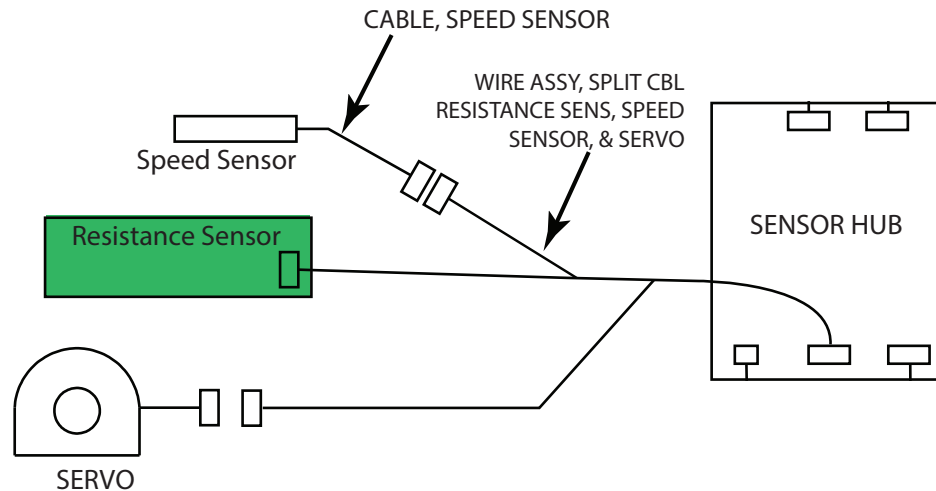

9. Re-assemble the machine in the reverse order of when the parts were removed.

10. Plug the power cord into the machine and wall outlet.

11. Power on the machine. After the Power-Up/Welcome screen appears, use the Resistance Level Quick keys 25 and 1 to confirm that the magnet caliper moves properly between resistance level 1 and 25.

12. Final Inspection

Inspect your machine to ensure that all hardware is tight and components are properly assembled.



Do not use until the machine has been fully assembled and inspected for correct performance in accordance with the Owner's Manual.

NOTICE: This document provides instructions for the replacement of the Roller Wheels on the Schwinn™ 490 / 590e Ellipticals.

If you need assistance, please contact Customer Service (if purchased in US/Canada) or your local distributor (if purchased outside US/Canada). To find your local distributor, go to: www.nautilusinternational.com

⚠ This icon means a potentially hazardous situation which, if not avoided, could result in death or serious injury. Read and understand all Warnings on this machine.

Nautilus, Inc., www.nautilus.com, 5415 Centerpoint Parkway, Groveport, OH 43125 U.S.A. - Customer Service: North America (800) 605-3369, csnls@nautilus.com | outside U.S. www.nautilusinternational.com | Printed in China | © 2023 Nautilus, Inc. | Schwinn and the Schwinn logo are trademarks owned or licensed by Nautilus, Inc., registered or otherwise protected by common law in the United States and other nations. | **ORIGINAL DOCUMENT - ENGLISH VERSION ONLY**

Important Safety Instructions - Before servicing or using this equipment, obey the following warnings:

⚠ This icon means a potentially hazardous situation which, if not avoided, could result in death or serious injury. Read and understand all Warnings on this machine.

⚠ DANGER

To reduce the risk of electrical shock or unsupervised usage of the equipment, always unplug the power cord from the wall outlet and wait 5 minutes before cleaning, maintaining or repairing this machine. Place the power cord in a secure location.

- Read and understand the Part Replacement Procedure before working on the machine. Failure to obey the instructions and safety warnings could cause injury to the service technician or bystanders.
- Keep bystanders and children away from the product being serviced at all times.
- Disconnect all power to the machine before you service it.
- Make sure that the repair is done in an appropriate work space away from foot traffic and exposure to bystanders.
- Some components of the equipment can be heavy or awkward. Enlist the service of a second person when you do maintenance steps involving these components. Do not try to do heavy or awkward steps on your own.
- Use only replacement parts and hardware that are supplied or approved by Nautilus. Failure to use Nautilus-approved replacement parts can adversely affect the safety and functionality of the equipment creating a risk to users and will void the warranty.
- Be sure that all warning stickers and instructional placards applied to the product stay present and in good condition when doing maintenance or replacing components. If at any time the Warning labels become loose, unreadable or dislodged, replace the labels. If purchased in US/Canada, contact Customer Service for replacement labels. If purchased outside US/Canada, contact your local distributor for them.
- Do not try to change the design or functionality of the machine being serviced as this can adversely affect user safety.
- Do not use the machine until all shrouds, instructions, warning labels and correct functionality have been verified and tested for correct performance.

• SAVE THESE INSTRUCTIONS

Tools Required (not included)

6mm Hex wrench



⚠ DANGER

To reduce the risk of electrical shock or unsupervised usage of the equipment, always unplug the power cord from the wall outlet and wait 5 minutes before cleaning, maintaining or repairing this machine. Place the power cord in a secure location.

Note: Your machine may not match the images provided exactly.

1. Unplug the AC Adapter from the wall outlet and machine.



2. There are two Rollers on each of the Legs. Each must be fully replaced separately. Using a 6mm hex wrench, remove the hardware (indicated by an oval) that secures one of the Rollers on the Leg. Remove the old Roller.

⚠ In order to avoid possible serious injury when removing the Roller Wheel Assembly, be careful to avoid fingers or hands being caught or pinched.

Be aware that the Legs, Pedal Arms and the Upper Handlebars are connected and when either of these parts move the other does as well.

3. Attach the new Roller, being sure to place the Wave Washer to the inside of the Roller, against the Leg.

4. Repeat the last two Steps to replace the other Roller on the same Leg.

5. Final Inspection

Inspect your machine to ensure that all hardware is tight and components are properly assembled.

⚠ Do not use until the machine has been fully assembled and inspected for correct performance in accordance with the Owner's Manual.



NOTICE: This document provides instructions for the replacement of the Sensor Hub on the Schwinn™ 490 / 590e Ellipticals.

If you need assistance, please contact Customer Service (if purchased in US/Canada) or your local distributor (if purchased outside US/Canada). To find your local distributor, go to: www.nautilusinternational.com

⚠ This icon means a potentially hazardous situation which, if not avoided, could result in death or serious injury. Read and understand all Warnings on this machine.

Nautilus, Inc., www.nautilus.com, 5415 Centerpoint Parkway, Groveport, OH 43125 U.S.A. - Customer Service: North America (800) 605-3369, csnls@nautilus.com | outside U.S. www.nautilusinternational.com | Printed in China | © 2023 Nautilus, Inc. | Schwinn and the Schwinn logo are trademarks owned or licensed by Nautilus, Inc., registered or otherwise protected by common law in the United States and other nations. | **ORIGINAL DOCUMENT - ENGLISH VERSION ONLY**

Important Safety Instructions - Before servicing or using this equipment, obey the following warnings:

⚠ This icon means a potentially hazardous situation which, if not avoided, could result in death or serious injury. Read and understand all Warnings on this machine.

⚠ DANGER To reduce the risk of electrical shock or unsupervised usage of the equipment, always unplug the power cord from the wall outlet and wait 5 minutes before cleaning, maintaining or repairing this machine. Place the power cord in a secure location.

- Read and understand the Part Replacement Procedure before working on the machine. Failure to obey the instructions and safety warnings could cause injury to the service technician or bystanders.
- Keep bystanders and children away from the product being serviced at all times.
- Disconnect all power to the machine before you service it.
- Make sure that the repair is done in an appropriate work space away from foot traffic and exposure to bystanders.
- Some components of the equipment can be heavy or awkward. Enlist the service of a second person when you do maintenance steps involving these components. Do not try to do heavy or awkward steps on your own.
- Use only replacement parts and hardware that are supplied or approved by Nautilus. Failure to use Nautilus-approved replacement parts can adversely affect the safety and functionality of the equipment creating a risk to users and will void the warranty.
- Be sure that all warning stickers and instructional placards applied to the product stay present and in good condition when doing maintenance or replacing components. If at any time the Warning labels become loose, unreadable or dislodged, replace the labels. If purchased in US/Canada, contact Customer Service for replacement labels. If purchased outside US/Canada, contact your local distributor for them.
- Do not try to change the design or functionality of the machine being serviced as this can adversely affect user safety.
- Do not use the machine until all shrouds, instructions, warning labels and correct functionality have been verified and tested for correct performance.

• SAVE THESE INSTRUCTIONS

Tools Required (not included)

Standard screwdriver



6mm hex wrench



⚠ DANGER

To reduce the risk of electrical shock or unsupervised usage of the equipment, always unplug the power cord from the wall outlet and wait 5 minutes before cleaning, maintaining or repairing this machine. Place the power cord in a secure location.

Note: Your machine may not match the images provided exactly.

1. Unplug the Power Cord from the wall outlet and machine.
2. Flex the edges of the Front Lower Shroud to disengage the 8 inside tabs from the Main Shrouds.

Note: It may be easier to pry up the edges of the Front Lower Shroud using a flathead screwdriver. To avoid damage to the surface of the Shrouds, we recommend putting a piece of cloth over the screwdriver blade.



Note: The Shrouds have been removed from some of the images to provide additional details.

3. Flex the sides of the Sensor Hub Cover to disengage the 2 side tabs.

4. Remove the connectors from the Sensor Hub after noting their locations.

Note: Be sure to note where all cables attach for re-assembly. Do not let the cables fall into the machine. If the Cable Connectors are secured by a small amount of glue, use a pair of small nose pliers to grab and remove the glue.

NOTICE: Do not cut or pinch the cables.



Note: Main Shrouds removed for clarity.

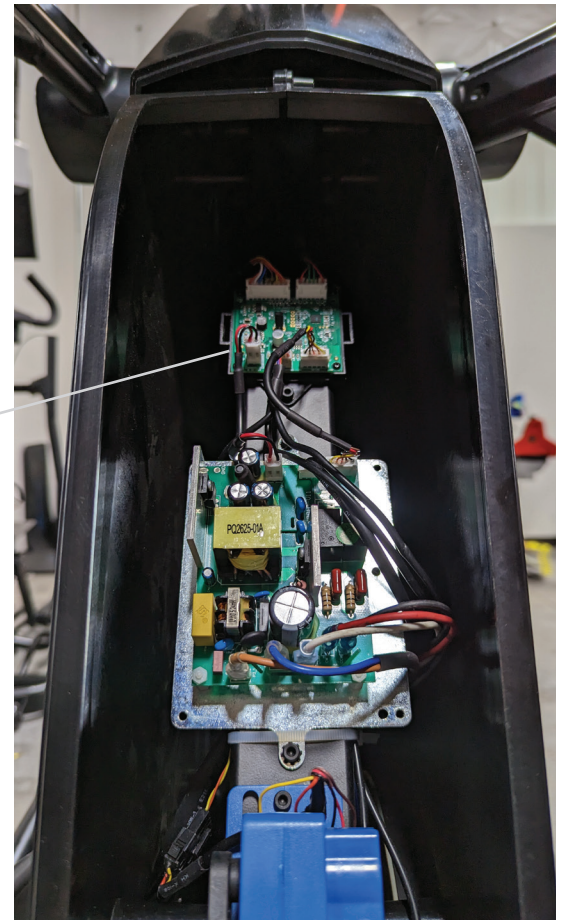

ELECTRICAL WIRING ROUTE DETAIL

- Sensor Board

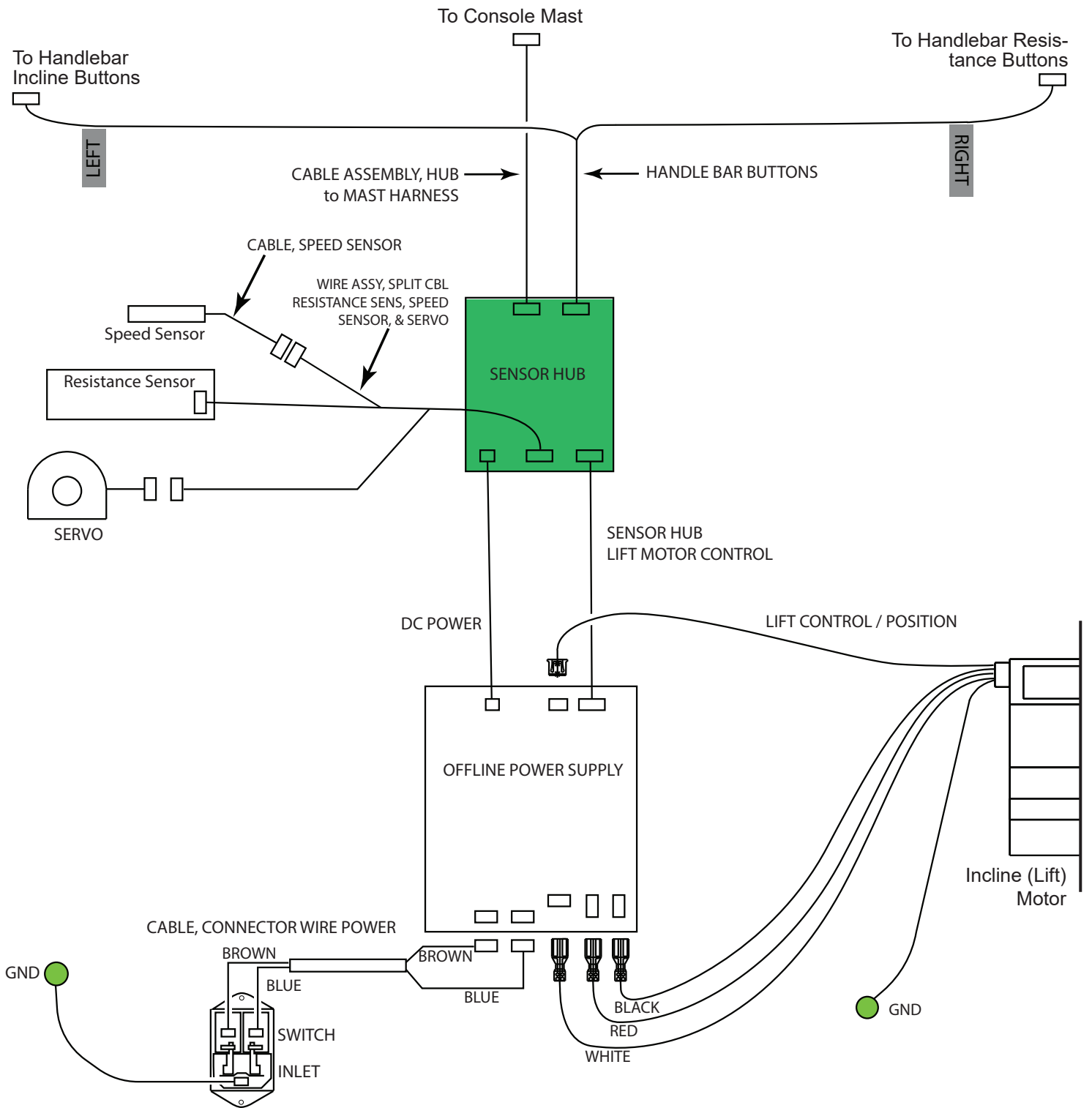

5. Using a 6mm hex wrench, remove the 2 screws (indicated by ovals) that attach the Sensor Hub to the Frame.

6. Remove the old Sensor Hub, and install the new Sensor Hub. Connect all the cables to the Sensor Hub in their proper locations. Be sure not to crimp any cables.

7. Re-install all remaining parts that were removed in reverse order.

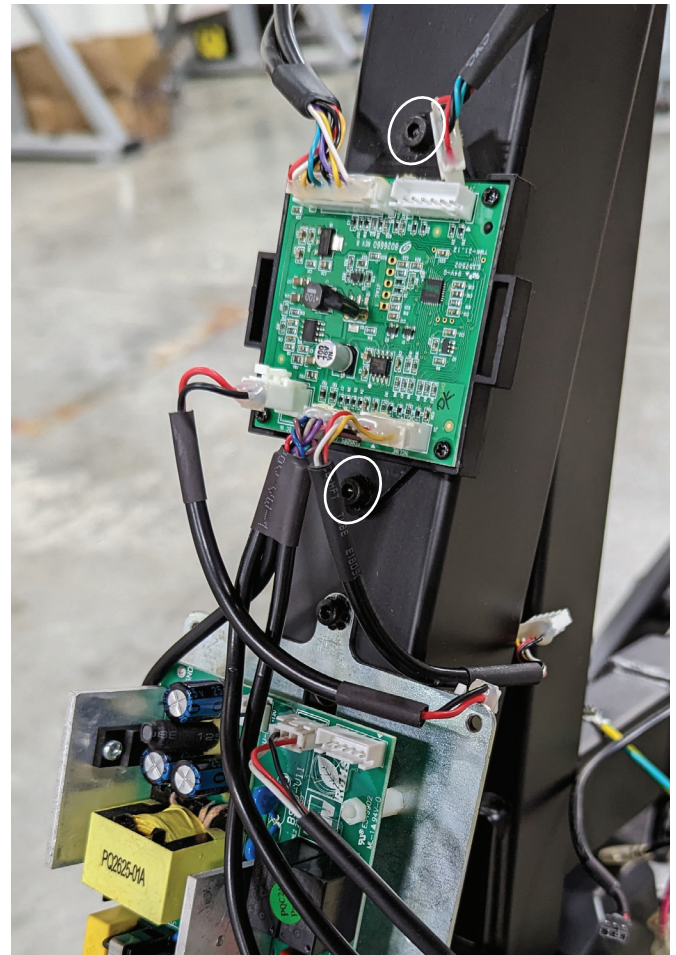

Calibrating the Resistance:

CAUTION Do not use the Console Resistance Quick Keys to set resistance until the calibration process is complete and calibration saved.

Note: During the calibration process no one should be pedaling the machine. Standing on the pedals is okay during the calibration process.

8. Plug the power cord into the machine and wall outlet, and flip the power switch to on.

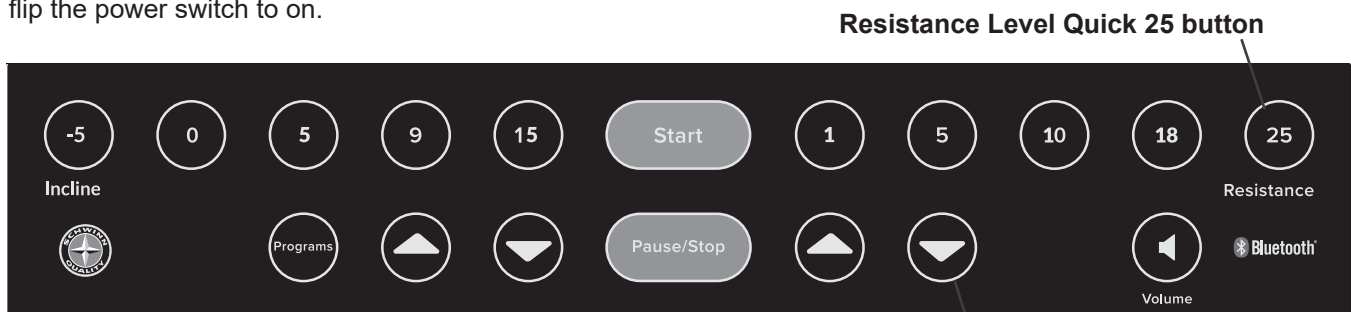

9. Push the Programs button and hold for 3 seconds while in the Power-Up Mode to go into the Console Setup Mode (System Menu).

Note: To exit the System Menu and return to the Power-Up Mode screen, push the Pause/Stop button.

10. The Console display shows the System Units prompt with the current setting. Tap the Programs button 4 times to advance through the System Menu.

11. The Console display shows the Hardware Variant & Console Firmware Version. The sample screen shows the format (values may be different).

Push and hold for 3 seconds the Resistance Level Quick 25 button to go to the Manufacturing Test Menu.

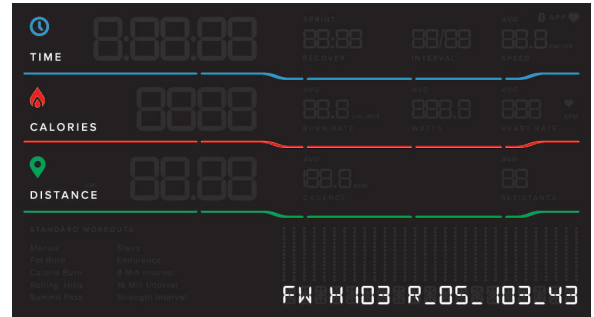

12. The Console display shows the START TEST SUITE menu option. Push the Resistance Down (▼) button 2 times to advance to the AUTO CAL_RESISTANCE (Automated Calibrate Resistance) option.

If the Start button was pushed instead of the Resistance Down (▼) button twice, turn the Power Switch to OFF and return to Step 1.

When the display shows “CALIBRATE RESISTANCE” do NOT push Start. This option is not used. Push the Resistance Down (▼) button one more time.

If the Resistance Down (▼) button was pushed more than 2 times going past the AUTO CAL_RESISTANCE option, push the Resistance Increase (▲) button to return to the AUTO CAL_RESISTANCE (Automated Calibrate Resistance) option.



13. The Console display shows the AUTO CAL_RESISTANCE (Automated Calibrate Resistance) option. Push the Start button.

Note: If the Pause/Stop button is pushed part way through the calibration (exit), the new calibration is not saved.

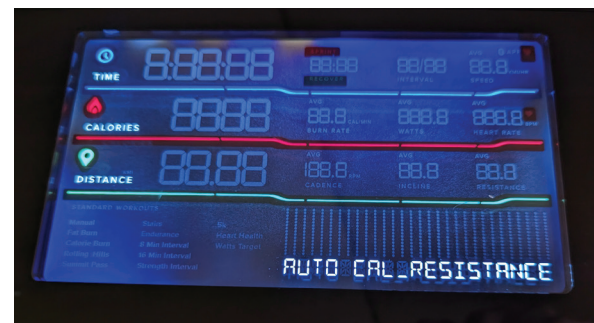

14. The console will display changing text and numbers for approximately 30 seconds as the servo motor moves.



15. The console display will change to “CNFRM C4095 AGC xx”.



16. Push the Start button to confirm and save the resistance calibration values. The display will momentarily change to “SAVING CAL”, then display “AUTO CAL_RESISTANCE”. Calibration is complete.

Note: Pushing the Pause/Stop button will abort the calibration process, with the new calibration values not being saved, and the last saved calibration values being restored.

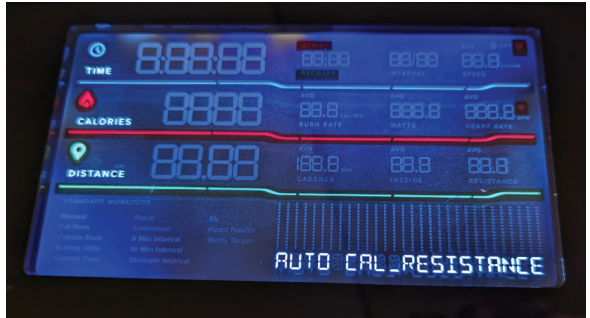

17. Power off the machine.

18. Power on the machine. After the Power-Up/Welcome screen appears, use the Resistance Level Quick keys 25 and 1 to confirm that the magnet caliper moves properly between resistance level 1 and 25.

Calibrating the Incline:

Note: During the Incline calibration process no one should be pedaling the machine or standing on the pedals.

Resistance Level Quick 25 button

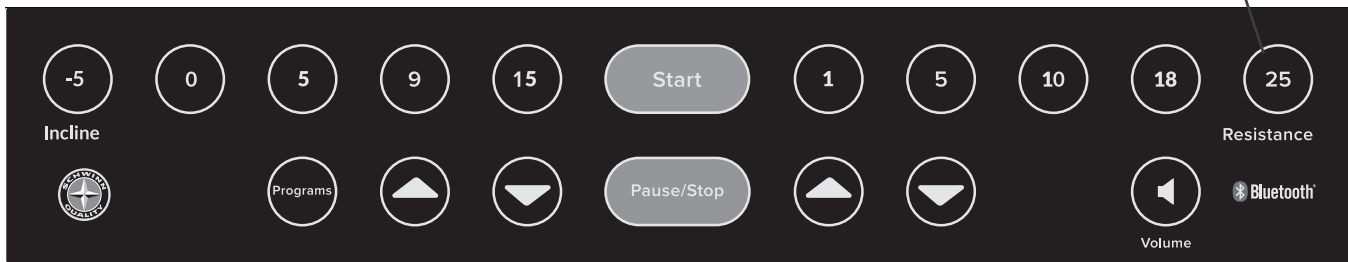

Resistance Down button

19. Push the Programs button and hold for 3 seconds while in the Power-Up Mode to go into the Console Setup Mode (System Menu).

Note: To exit the System Menu and return to the Power-Up Mode screen, push the Pause/Stop button.

20. The Console display shows the System Units prompt with the current setting. Tap the Programs button 4 times to advance through the System Menu.

21. The Console display shows the Hardware Variant & Console Firmware Version. The sample screen shows the format (values may be different).

Push and hold for 3 seconds the Resistance Level Quick 25 button to go to the Manufacturing Test Menu.

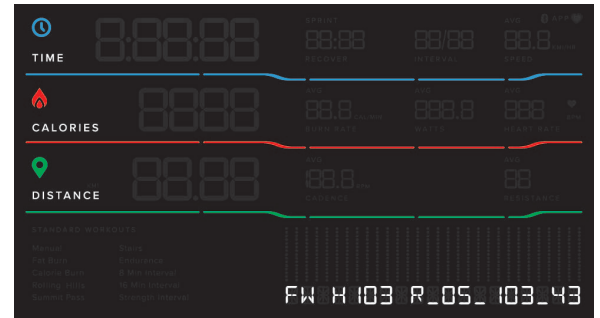

22. The Console display shows the START TEST SUITE menu option. Push the Resistance Decrease (▼) button 3 times to advance to the CAL_INCLINE option.

If the Start button was pushed instead of the Resistance Decrease (▼) button twice, turn the Power Switch to OFF and return to Step 1.

If the Resistance Decrease (▼) button was pushed more than 3 times going past the CAL_INCLINE option, push the Resistance Increase (▲) button to return to the CAL_INCLINE option.



23. The Console display shows the CAL_INCLINE option. Push the Start button.

Note: If the Pause/Stop button is pushed part way through the calibration (exit), the new calibration is not saved.



24. The console will display changing text and numbers for approximately 30 seconds as the incline motor fully raises the Pedals, then fully lowers the Pedals, and then brings the Pedals to the level or "0" setting.

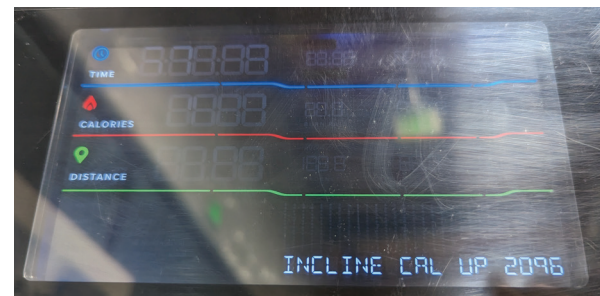

25. The console display will change to “CNFRM AT LVL 0 24XX”.

Note: The 0 incline level can be trimmed here for near perfect level position by using the Incline Increase (▲) and Incline Decrease (▼) buttons. If a finer level of adjustment is needed, use the Incline Level Quick 9 button to slightly increase, or the Incline Level Quick 15 button to slightly decrease.



26. Push the Start button to confirm and save the incline calibration values. The display will momentarily change to “SAVE ZERO LVL:24XX”, then display “CAL_INCLINE”. Calibration is complete.

Note: Pushing the Pause/Stop button will abort the calibration process, with the new calibration values not being saved, and the last saved calibration values being restored.

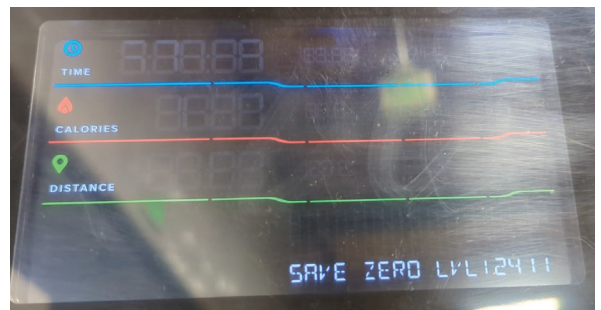

27. Power off the machine.

28. Power on the machine. After the Power-Up/Welcome screen appears, use the Incline Level Quick keys 15 and -5 to confirm that the incline moves properly between incline level -5 and 15.

29. Final Inspection

Inspect your machine to ensure that all hardware is tight and components are properly assembled.



Do not use until the machine has been fully assembled and inspected for correct performance in accordance with the Owner's Manual.

NOTICE: This document provides instructions for the replacement of the Servo Motor on the Schwinn™ 490 / 590e Ellipticals.

If you need assistance, please contact Customer Service (if purchased in US/Canada) or your local distributor (if purchased outside US/Canada). To find your local distributor, go to: www.nautilusinternational.com

⚠ This icon means a potentially hazardous situation which, if not avoided, could result in death or serious injury. Read and understand all Warnings on this machine.

Nautilus, Inc., www.nautilus.com, 5415 Centerpoint Parkway, Groveport, OH 43125 U.S.A. - Customer Service: North America (800) 605-3369, csnls@nautilus.com | outside U.S. www.nautilusinternational.com | Printed in China | © 2023 Nautilus, Inc. | Schwinn and the Schwinn logo are trademarks owned or licensed by Nautilus, Inc., registered or otherwise protected by common law in the United States and other nations. | **ORIGINAL DOCUMENT - ENGLISH VERSION ONLY**

Important Safety Instructions - Before servicing or using this equipment, obey the following warnings:

⚠ This icon means a potentially hazardous situation which, if not avoided, could result in death or serious injury. Read and understand all Warnings on this machine.

⚠ DANGER To reduce the risk of electrical shock or unsupervised usage of the equipment, always unplug the power cord from the wall outlet and wait 5 minutes before cleaning, maintaining or repairing this machine. Place the power cord in a secure location.

- Read and understand the Part Replacement Procedure before working on the machine. Failure to obey the instructions and safety warnings could cause injury to the service technician or bystanders.
- Keep bystanders and children away from the product being serviced at all times.
- Disconnect all power to the machine before you service it.
- Make sure that the repair is done in an appropriate work space away from foot traffic and exposure to bystanders.
- Some components of the equipment can be heavy or awkward. Enlist the service of a second person when you do maintenance steps involving these components. Do not try to do heavy or awkward steps on your own.
- Use only replacement parts and hardware that are supplied or approved by Nautilus. Failure to use Nautilus-approved replacement parts can adversely affect the safety and functionality of the equipment creating a risk to users and will void the warranty.
- Be sure that all warning stickers and instructional placards applied to the product stay present and in good condition when doing maintenance or replacing components. If at any time the Warning labels become loose, unreadable or dislodged, replace the labels. If purchased in US/Canada, contact Customer Service for replacement labels. If purchased outside US/Canada, contact your local distributor for them.
- Do not try to change the design or functionality of the machine being serviced as this can adversely affect user safety.
- Do not use the machine until all shrouds, instructions, warning labels and correct functionality have been verified and tested for correct performance.

• SAVE THESE INSTRUCTIONS

Tools Required (not included)

#2 Phillips screwdriver

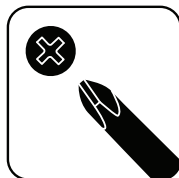

Standard screwdriver



⚠ DANGER

To reduce the risk of electrical shock or unsupervised usage of the equipment, always unplug the power cord from the wall outlet and wait 5 minutes before cleaning, maintaining or repairing this machine. Place the power cord in a secure location.

Note: Your machine may not match the images provided exactly.

1. Unplug the AC Adapter from the wall outlet and machine.

2. Flex the edges of the Front Lower Shroud to disengage the 6 inside tabs from the Main Shrouds.

Note: It may be easier to pry up the edges of the Front Lower Shroud using a flathead screwdriver. To avoid damage to the surface of the Shrouds, we recommend putting a piece of cloth over the screwdriver blade.

Note: All Shrouds have been removed for clarity.

⚠ Make sure that power to the machine is disconnected before beginning this step.

3. Carefully disconnect the Servo Motor Cable Connectors.
NOTICE: Do not pinch or cut the cables.

4. Using a standard screwdriver, gently separate the tabs (indicated by oval) that connects the Servo Motor Linkage to the Servo Motor.

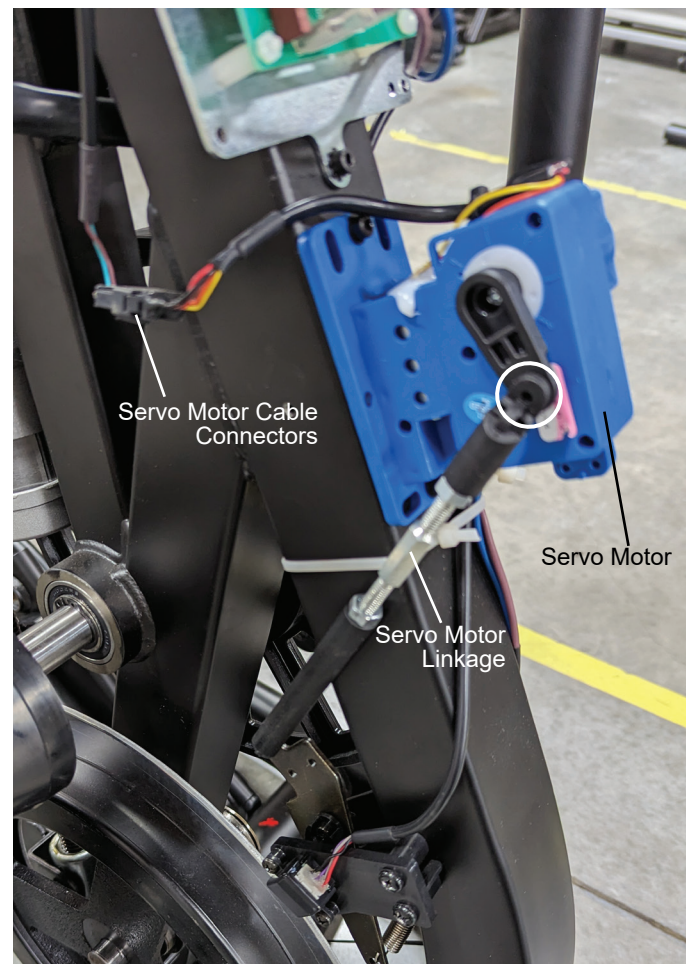
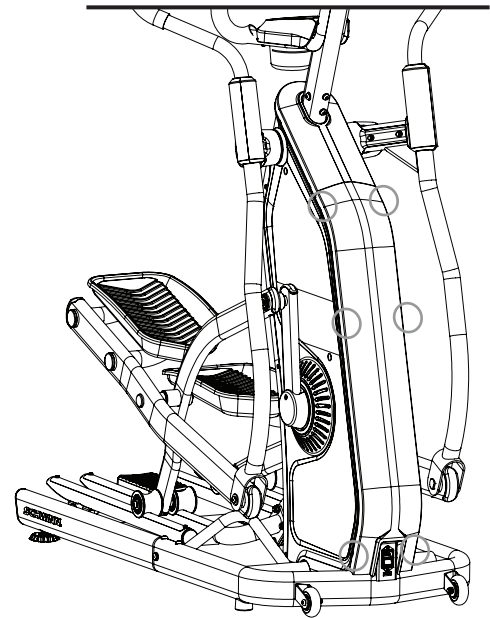

5. Using a 3mm hex wrench, remove the hardware (indicated by ovals) from the old Servo Motor.

6. Using a 3mm hex wrench, attach the new Servo Motor to the Frame.

Be sure that the Servo Motor Arm is in the range shown below before securing the Linkage Arm.

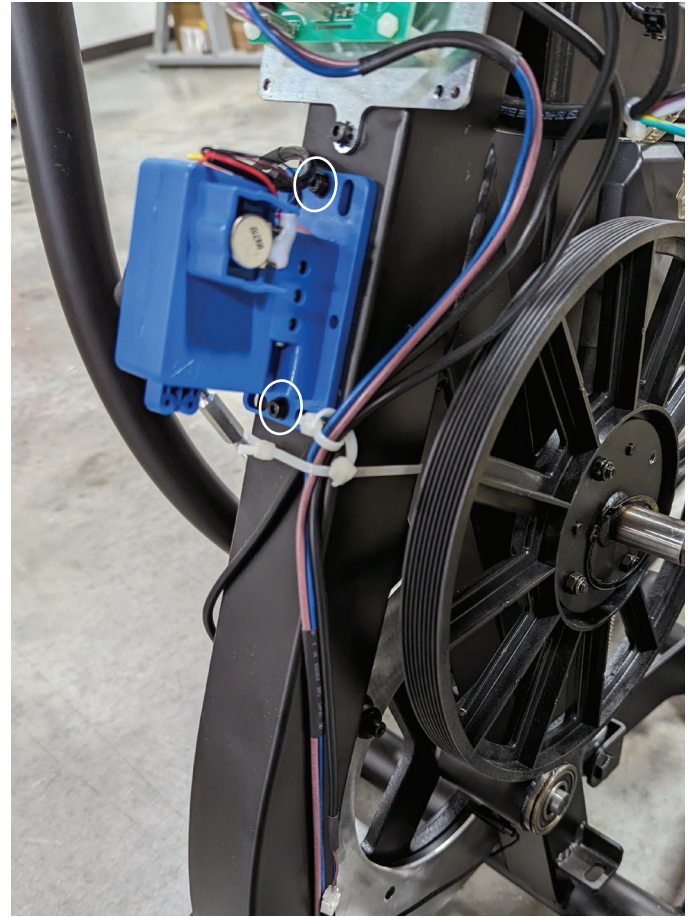
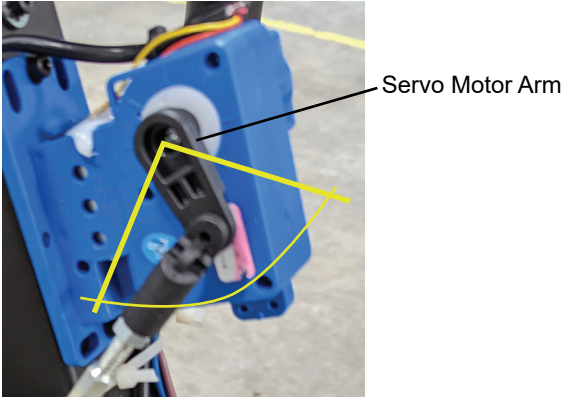

7. Connect the tabs on the end of the Linkage Arm to the Brake Assembly.

8. Connect the Servo Motor Cable Connectors.

NOTICE: Do not pinch or cut the cables.

ELECTRICAL WIRING ROUTE DETAIL - Servo Motor

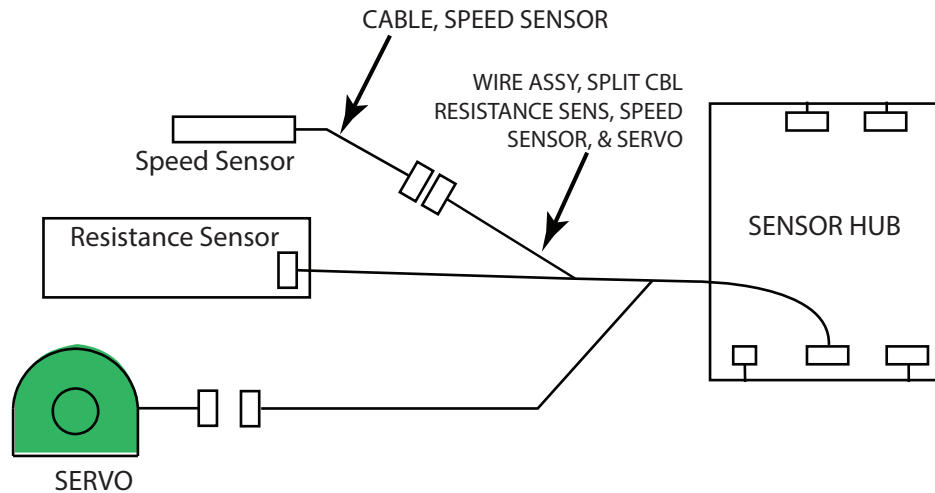

9. Re-assemble the machine in the reverse order of when the parts were removed.

10. Plug the power cord into the machine and wall outlet.

11. Power on the machine. After the Power-Up/Welcome screen appears, use the Resistance Level Quick keys 25 and 1 to confirm that the magnet caliper moves properly between resistance level 1 and 25.

12. Final Inspection

Inspect your machine to ensure that all hardware is tight and components are properly assembled.



Do not use until the machine has been fully assembled and inspected for correct performance in accordance with the Owner's Manual.

NOTICE: This document provides instructions for the replacement of the Shrouds on the Schwinn™ 490 / 590e Ellipticals.

If you need assistance, please contact Customer Service (if purchased in US/Canada) or your local distributor (if purchased outside US/Canada). To find your local distributor, go to: www.nautilusinternational.com

⚠ This icon means a potentially hazardous situation which, if not avoided, could result in death or serious injury. Read and understand all Warnings on this machine.

Nautilus, Inc., www.nautilus.com, 5415 Centerpoint Parkway, Groveport, OH 43125 U.S.A. - Customer Service: North America (800) 605-3369, csnls@nautilus.com | outside U.S. www.nautilusinternational.com | Printed in China | © 2023 Nautilus, Inc. | Schwinn and the Schwinn logo are trademarks owned or licensed by Nautilus, Inc., registered or otherwise protected by common law in the United States and other nations. | ORIGINAL DOCUMENT - ENGLISH VERSION ONLY

Important Safety Instructions - Before servicing or using this equipment, obey the following warnings:

⚠ This icon means a potentially hazardous situation which, if not avoided, could result in death or serious injury. Read and understand all Warnings on this machine.

⚠ DANGER To reduce the risk of electrical shock or unsupervised usage of the equipment, always unplug the power cord from the wall outlet and wait 5 minutes before cleaning, maintaining or repairing this machine. Place the power cord in a secure location.

- Read and understand the Part Replacement Procedure before working on the machine. Failure to obey the instructions and safety warnings could cause injury to the service technician or bystanders.
- Keep bystanders and children away from the product being serviced at all times.
- Disconnect all power to the machine before you service it.
- Make sure that the repair is done in an appropriate work space away from foot traffic and exposure to bystanders.
- Some components of the equipment can be heavy or awkward. Enlist the service of a second person when you do maintenance steps involving these components. Do not try to do heavy or awkward steps on your own.
- Use only replacement parts and hardware that are supplied or approved by Nautilus. Failure to use Nautilus-approved replacement parts can adversely affect the safety and functionality of the equipment creating a risk to users and will void the warranty.
- Be sure that all warning stickers and instructional placards applied to the product stay present and in good condition when doing maintenance or replacing components. If at any time the Warning labels become loose, unreadable or dislodged, replace the labels. If purchased in US/Canada, contact Customer Service for replacement labels. If purchased outside US/Canada, contact your local distributor for them.
- Do not try to change the design or functionality of the machine being serviced as this can adversely affect user safety.
- Do not use the machine until all shrouds, instructions, warning labels and correct functionality have been verified and tested for correct performance.

• SAVE THESE INSTRUCTIONS

Tools Required (not included)

#2 Phillips screwdriver



Piece of string or wire, about 60 cm (24 inches) long

Standard screwdriver



Adjustable wrench

Crank puller

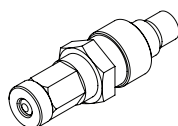

⚠ DANGER

To reduce the risk of electrical shock or unsupervised usage of the equipment, always unplug the power cord from the wall outlet and wait 5 minutes before cleaning, maintaining or repairing this machine. Place the power cord in a secure location.

Note: Your machine may not match the images provided exactly.

1. Unplug the Power Cord from the wall outlet and machine.

To replace the:

Front Lower Shroud

Section 1

this page

Front Upper Shroud

Section 2

page 3

Rear Shroud

Section 3

page 5

Main Shrouds

All Sections (1-4)

this page

For Re-Assembly and Final Inspection

Section 5

page 14

Section 1 - Replacing the Front Shroud

1. Flex the edges of the Front Lower Shroud to disengage the 8 inside tabs from the Main Shrouds.

Note: It may be easier to pry up the edges of the Front Lower Shroud using a flathead screwdriver. To avoid damage to the surface of the Shrouds, we recommend putting a piece of cloth over the screwdriver blade.



Section 2 - Replacing the Front Upper Shroud

1. If replacing the Upper Front Shroud, remove the hardware (indicated with oval) that attaches the Console Mast with a 6mm hex wrench.
2. Slightly lift the Console Mast from the Frame Assembly and disconnect the Cables. Fully remove the Console Mast with Cables.

Note: Do not pinch or cut the Cables. Do not allow the Cable to fall into the Frame Assembly.

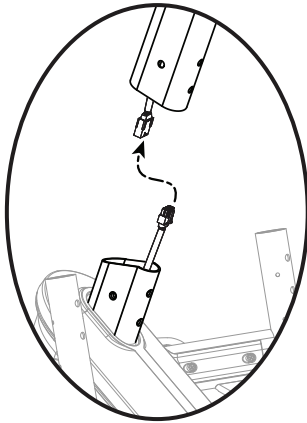

3. Flex the edges of the Front Upper Shroud to disengage the 4 inside tabs (2 on each side) from the Main Shrouds.

4. Place the new Front Upper Shroud onto the Frame Assembly.

5. With the Console Mast, connect the cable to the cable from the Frame Assembly. Align the clips on the cable connectors and make sure the connectors lock.

NOTICE: Do not cut or pinch the cables. This step may require two people.

6. Using a 6mm hex wrench, attach the Console Mast to the Main Assembly.

NOTICE: Make sure the Console Cable does not fall into the Console Mast. Do not cut or pinch the cables.

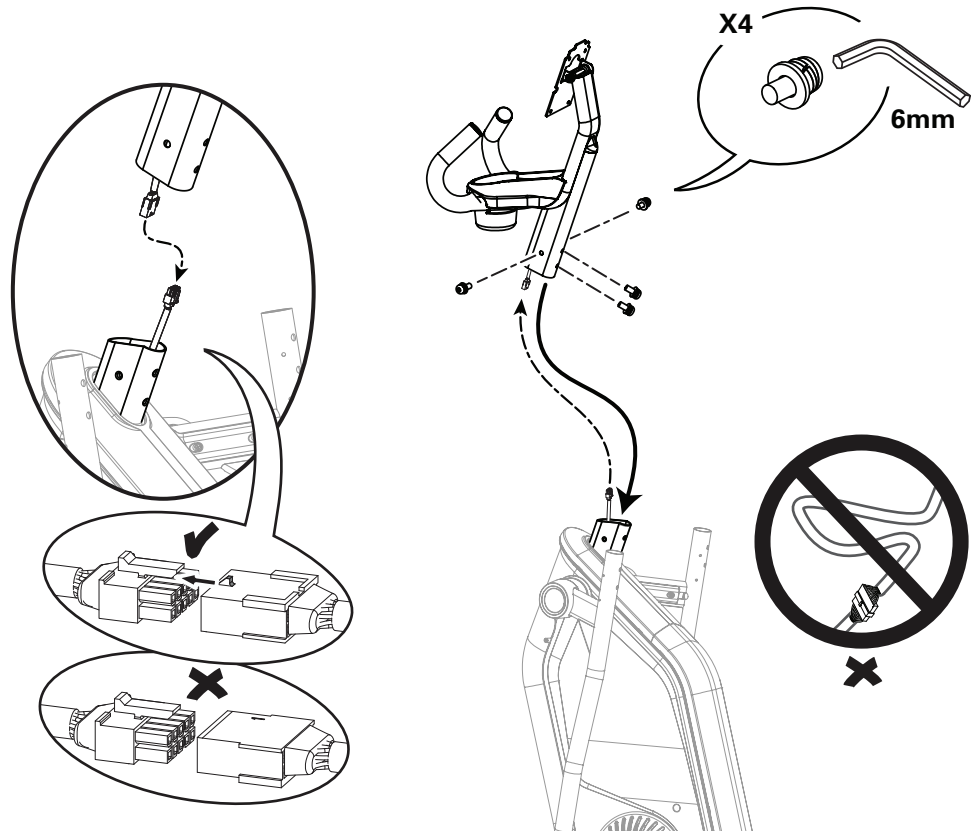

Section 3 - Replacing the Rear Shroud

1. If replacing the Rear Shroud, the Incline Arm will need to be released. Using 6mm hex wrench and a 13mm open faced wrench, remove the indicated hardware that attaches the Incline Arm.

2. Slide the Incline (Lift) Motor Arm from the Rail Assembly.

⚠ In order to avoid possible serious injury, when the Rail Assembly has been released from the Main Assembly, be careful to avoid fingers or hands being caught or pinched. Do not place fingers or hands below any pivoting parts of the Rail Assembly.



3. Using a #2 Phillips screwdriver, remove the 4 screws (2 indicated on this side of the machine by ovals) from the Rear Shroud.

4. Gently pivot the Rear Shroud down along the Incline (Lift) Motor Arm and remove it.



Section 4 - Replacing the Main Shrouds (continued after previous sections)

Note: To replace the Main Shrouds, the Front Lower and Rear Shrouds must be removed, and the Front Upper Shroud needs to be resting unsecured on the Main Shrouds.

1. Gently compress the Exterior Handlebar Cover to release it from the Interior Handlebar Cover. There are five tabs that snap to secure each Cover.



2. Using a #2 Phillips screwdriver, remove the two screws that attach the Interior Handlebar Cover to the Handlebars. Set the hardware safely aside for reassembly.



3. Using a 6mm hex wrench, remove the four screws that attach the Upper Handlebar to the Lower Handlebar.

4. Slightly pull the Upper Handlebar out of the Lower Handlebar, and disconnect the cables. Set the old Upper Handlebar and hardware safely aside.

NOTICE: Do not cut or pinch the cables. Do not let the cable fall down into the Lower Handlebar. This step may require two people.

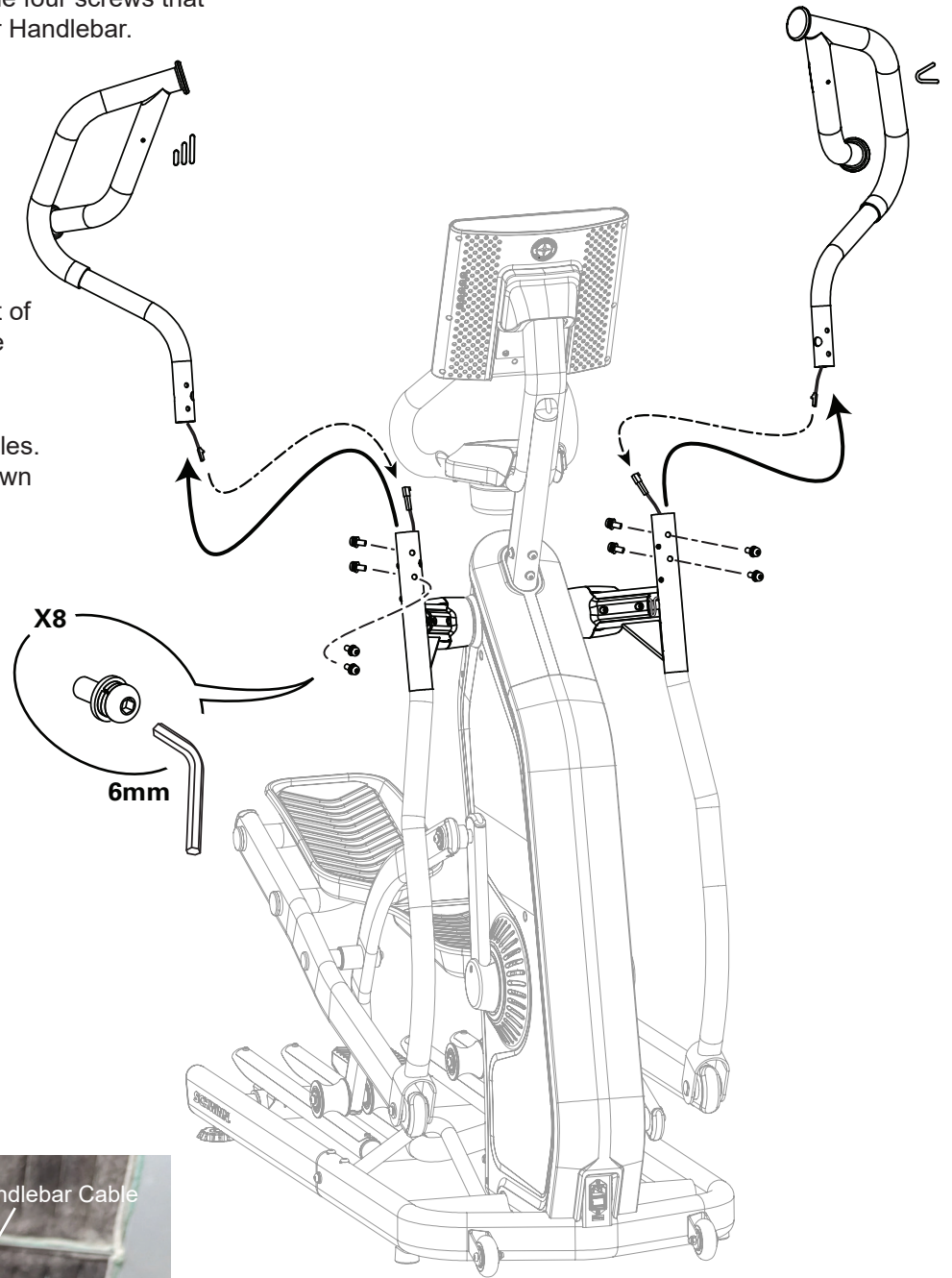

5. Using a 6mm hex wrench, remove the hardware (indicated by ovals) that attaches the Pedals and remove them.



Note: To assist with re-assembly, notice that the Pivot Pin is flush with the outside of the Lower Handlebar.



There is also a Wave Washer on the post from the Pedal.

Note: With the Pedal removed, do not fully rotate the Lower Handlebars or damage to the cables in the Handlebars will occur.

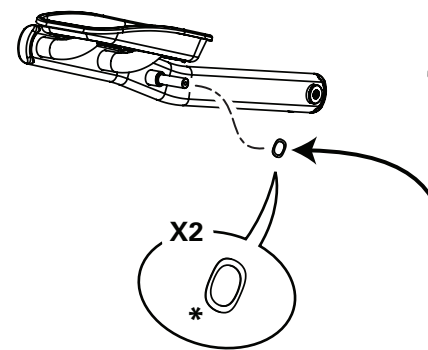

6. Using a 6mm hex wrench, remove the hardware (indicated by an oval) from the Legs and remove them.

Note: To assist with re-assembly, notice there is a Wave Washer on the post from the Crank Arm.



7. Using a #2 Phillips screwdriver, remove the indicated screw from the Crank Cap Shroud from the Crank Arm.



8. Using a 14mm wrench and socket, remove the Hex Nut from the Crank Arm.



Note: Your machine may not match the following images exactly.

9. Thread the Crank Puller into the Crank Arm (B). When the Crank Puller is in the correct position, only 1-2 threads on the outer portion (CP2) of the Crank Puller should show.

Note: Be sure the end of the Bolt (CP1) of the Crank Puller is flush with the Nut (CP2) as shown, before use.

Crank puller nut and inner bolt

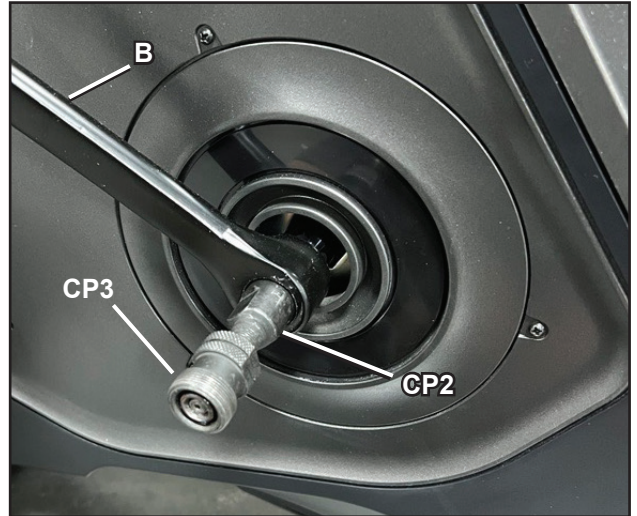
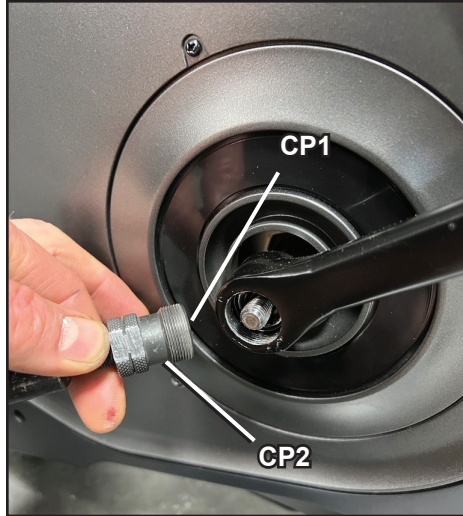

10. Using a wrench, turn the inner portion (CP3) of the Crank Puller clockwise. The Crank Arm (B) will slide off as it is tightened.

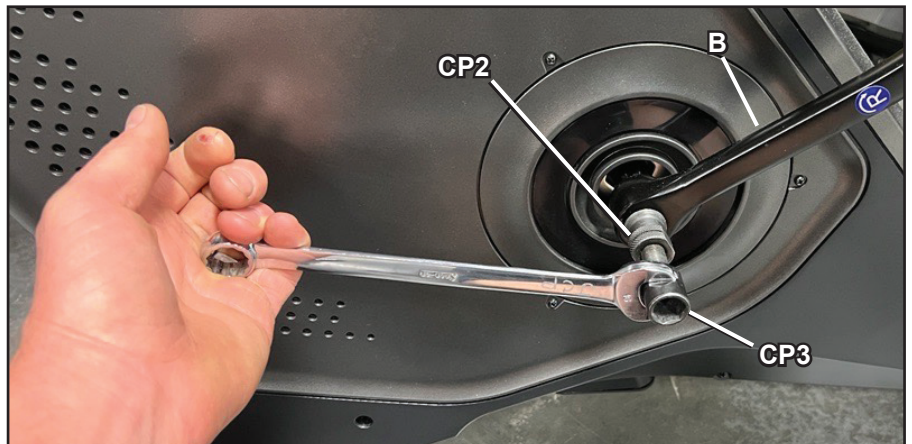

11. Gently compress the sides of the Pivot Cap to release it from the Inner Pivot Shroud.

12. Using a #2 Phillips screwdriver, remove the 2 screws from the Inner Pivot Shroud.

13. Tie a 60 cm (24 inch) long piece of wire or string to the end of the Cable. This wire or string will be used to pull the new cable through and out of the Lower Handlebar.

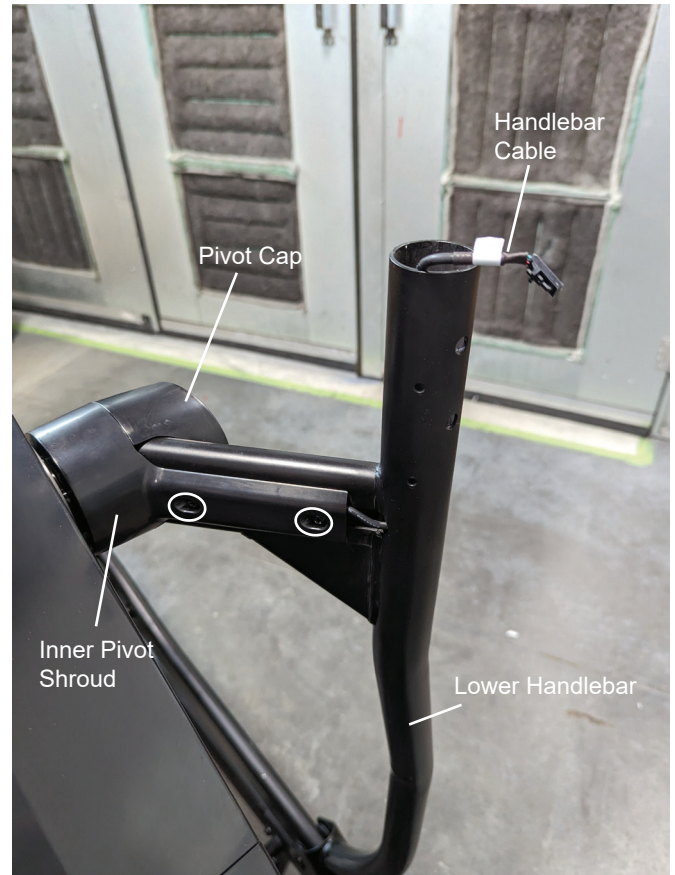

14. Using a 6mm hex wrench, remove the hardware (indicated by oval) that secures the Lower Handlebar.

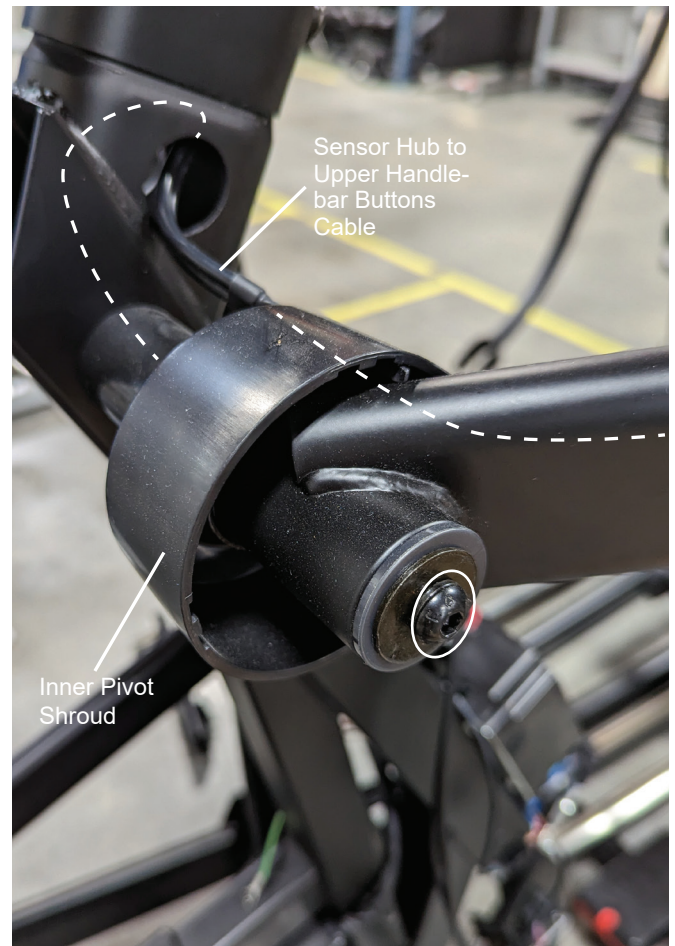

15. Slide the Lower Handlebar outward only about 1 inch (2.5 cm) from the machine.

16. Push the Inner Pivot Shroud toward the machine, off of the Lower Handlebar. This will release the Cable from the clips on the Inner Pivot Shroud.



17. With the wire or string still attached to the end of the Cable, pull the Cable toward the machine out of the Lower Handlebar. Be sure not to pull the end of the wire or string into the Lower Handlebar.

18. Remove the wire or string from the Cable, and tie the wire or string off at both ends of the Lower Handlebar. This will be used to route the Cable back through the Lower Handlebar.

19. Fully remove the Lower Handlebar from the Pivot Rod.

If replacing the Left Main Shroud, repeat the steps to remove the Left Lower Handlebar.

20. Using a #2 Phillips screwdriver, remove the 8 screws from the Right Main Shroud.

Note: The Upper Front Shroud may need to be lifted to access the upper screw for the Right Main Shroud.



Note: Crank Arm and Lower Handlebar have been removed, but are shown here.

21. Using a #2 Phillips screwdriver, remove the 3 screws from the Left Main Shroud.



Note: Crank Arm and Lower Handlebar have been removed, but are shown here.

Section 5 - Re-assembly and Final Inspection

1. Re-install all remaining parts that were removed in reverse order.

2. Final Inspection

Inspect your machine to ensure that all hardware is tight and components are properly assembled.



Do not use until the machine has been fully assembled and inspected for correct performance in accordance with the Owner's Manual.

NOTICE: This document provides instructions for the replacement of the Speed Sensor on the Schwinn™ 490 / 590e Ellipticals.

If you need assistance, please contact Customer Service (if purchased in US/Canada) or your local distributor (if purchased outside US/Canada). To find your local distributor, go to: www.nautilusinternational.com

⚠ This icon means a potentially hazardous situation which, if not avoided, could result in death or serious injury. Read and understand all Warnings on this machine.

Nautilus, Inc., www.nautilus.com, 5415 Centerpoint Parkway, Groveport, OH 43125 U.S.A. - Customer Service: North America (800) 605-3369, csnls@nautilus.com | outside U.S. www.nautilusinternational.com | Printed in China | © 2023 Nautilus, Inc. | Schwinn and the Schwinn logo are trademarks owned or licensed by Nautilus, Inc., registered or otherwise protected by common law in the United States and other nations. | ORIGINAL DOCUMENT - ENGLISH VERSION ONLY

Important Safety Instructions - Before servicing or using this equipment, obey the following warnings:

⚠ This icon means a potentially hazardous situation which, if not avoided, could result in death or serious injury. Read and understand all Warnings on this machine.

⚠ DANGER To reduce the risk of electrical shock or unsupervised usage of the equipment, always unplug the power cord from the wall outlet and wait 5 minutes before cleaning, maintaining or repairing this machine. Place the power cord in a secure location.

- Read and understand the Part Replacement Procedure before working on the machine. Failure to obey the instructions and safety warnings could cause injury to the service technician or bystanders.
- Keep bystanders and children away from the product being serviced at all times.
- Disconnect all power to the machine before you service it.
- Make sure that the repair is done in an appropriate work space away from foot traffic and exposure to bystanders.
- Some components of the equipment can be heavy or awkward. Enlist the service of a second person when you do maintenance steps involving these components. Do not try to do heavy or awkward steps on your own.
- Use only replacement parts and hardware that are supplied or approved by Nautilus. Failure to use Nautilus-approved replacement parts can adversely affect the safety and functionality of the equipment creating a risk to users and will void the warranty.
- Be sure that all warning stickers and instructional placards applied to the product stay present and in good condition when doing maintenance or replacing components. If at any time the Warning labels become loose, unreadable or dislodged, replace the labels. If purchased in US/Canada, contact Customer Service for replacement labels. If purchased outside US/Canada, contact your local distributor for them.
- Do not try to change the design or functionality of the machine being serviced as this can adversely affect user safety.
- Do not use the machine until all shrouds, instructions, warning labels and correct functionality have been verified and tested for correct performance.

• SAVE THESE INSTRUCTIONS

Tools Required (not included)

Short #2 Phillips screwdriver



(1) Zip-Tie (Replacement)
Something to cut a Zip-Tie



⚠ DANGER

To reduce the risk of electrical shock or unsupervised usage of the equipment, always unplug the power cord from the wall outlet and wait 5 minutes before cleaning, maintaining or repairing this machine. Place the power cord in a secure location.

Note: Your machine may not match the images provided exactly.

1. Unplug the AC Adapter from the wall outlet and machine.

2. Flex the edges of the Front Lower Shroud to disengage the 8 inside tabs from the Main Shrouds.

Note: It may be easier to pry up the edges of the Front Lower Shroud using a flathead screwdriver. To avoid damage to the surface of the Shrouds, we recommend putting a piece of cloth over the screwdriver blade.



3. Using a #2 Phillips screwdriver, remove the screw that secures the Right and Left Main Shrouds just above the exposed Flywheel.

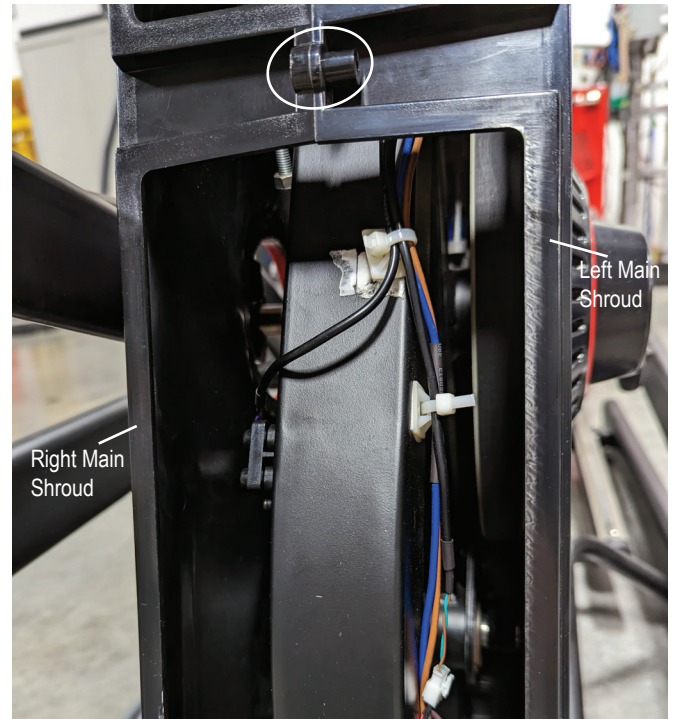

4. Using a #2 Phillips screwdriver, remove the screw (indicated by oval) that secures the Left Main Shroud to the Frame.



Note: The Speed Sensor can be accessed by gently flexing the Left Main Shroud outward slightly.

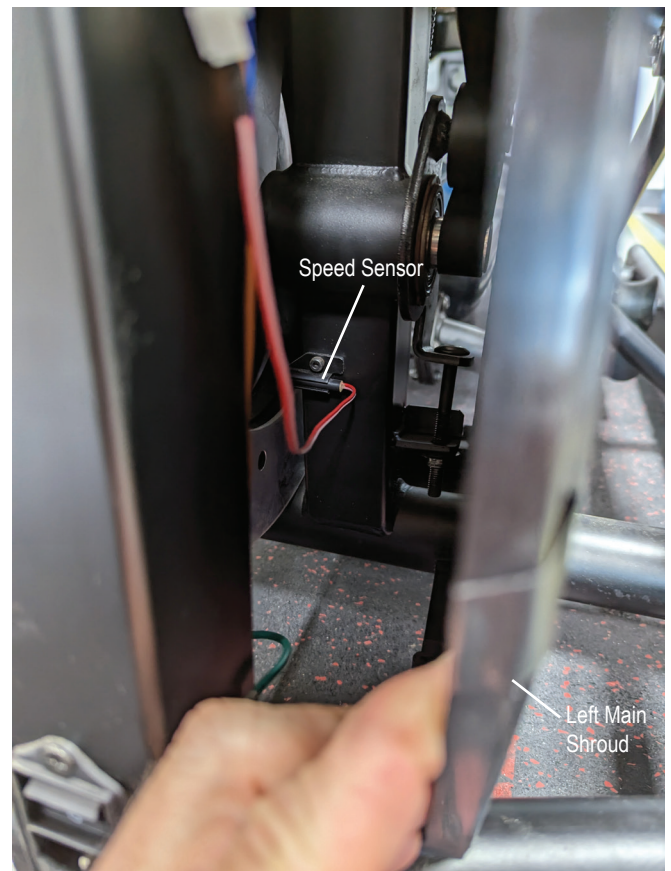

Note: The Shrouds have been removed from the images to provide additional details.

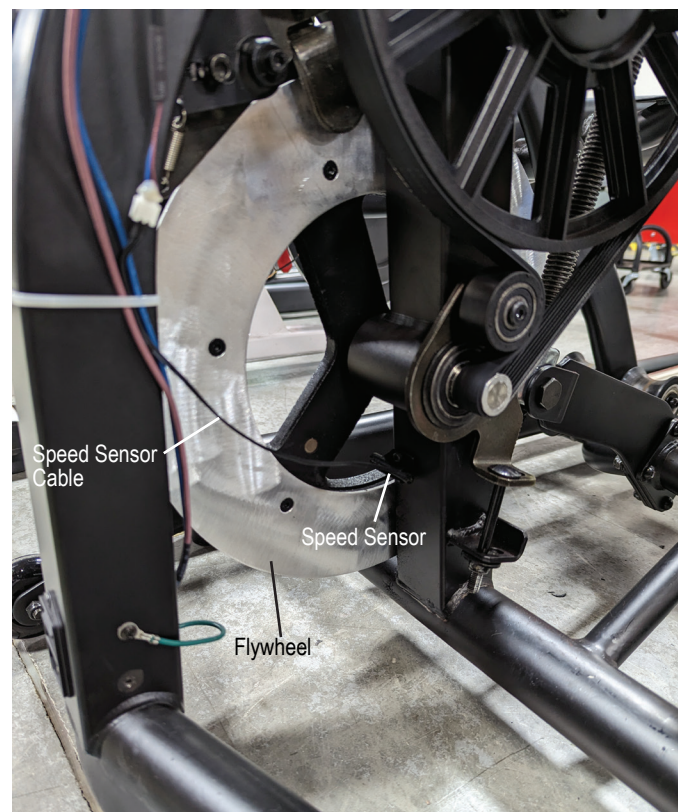

Note: Main Shrouds removed for clarity.

5. After noting how the Zip-Tie secures the Speed Sensor Cable and other cables to the Frame, cut the Zip-Tie that secures the cables. Be sure not to damage or cut any cables.

6. Disconnect the Speed Sensor Cable Connector.

7. Using a short #2 Phillips screwdriver, remove the screw that secures the Speed Sensor Bracket to the Frame. Remove the old Speed Sensor Assembly.

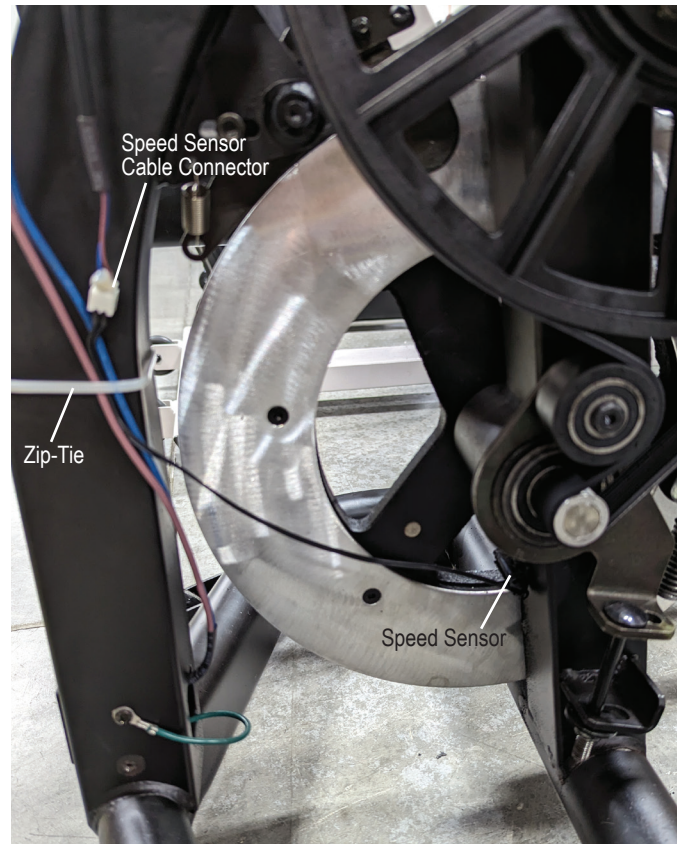

8. Using a #2 Phillips screwdriver, connect the new Speed Sensor Assembly to the Frame. Be sure not to pinch or cut any of the wires. A built-in stop is provided in the Speed Sensor Bracket to assist with properly placing the Speed Sensor. Push the Speed Sensor into the Bracket until it reaches the stop.

9. Connect the new Speed Sensor Cable to the Connector.

10. Using a replacement Zip-Tie, secure the cables to the Frame and trim the excess from the Zip-Tie. Be sure not to cut any of the cables.

11. Re-assemble the machine in the reverse order of when the parts were removed.

12. Final Inspection

Inspect your machine to ensure that all hardware is tight and components are properly assembled.

⚠ Do not use until the machine has been fully assembled and inspected for correct performance in accordance with the Owner's Manual.

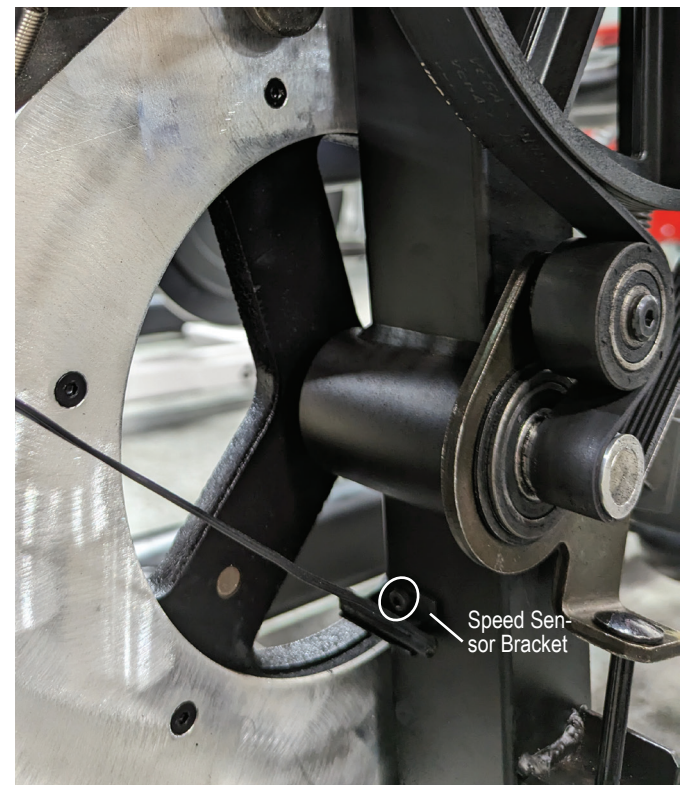

NOTICE: This document provides instructions for the replacement of the Upper Handlebars on the Schwinn™ 490 / 590e Ellipticals.

If you need assistance, please contact Customer Service (if purchased in US/Canada) or your local distributor (if purchased outside US/Canada). To find your local distributor, go to: www.nautilusinternational.com

⚠ This icon means a potentially hazardous situation which, if not avoided, could result in death or serious injury. Read and understand all Warnings on this machine.

Nautilus, Inc., www.nautilus.com, 5415 Centerpoint Parkway, Groveport, OH 43125 U.S.A. - Customer Service: North America (800) 605-3369, csnls@nautilus.com | outside U.S. www.nautilusinternational.com | Printed in China | © 2023 Nautilus, Inc. | Schwinn and the Schwinn logo are trademarks owned or licensed by Nautilus, Inc., registered or otherwise protected by common law in the United States and other nations. | **ORIGINAL DOCUMENT - ENGLISH VERSION ONLY**

Important Safety Instructions - Before servicing or using this equipment, obey the following warnings:

⚠ This icon means a potentially hazardous situation which, if not avoided, could result in death or serious injury. Read and understand all Warnings on this machine.

⚠ DANGER To reduce the risk of electrical shock or unsupervised usage of the equipment, always unplug the power cord from the wall outlet and wait 5 minutes before cleaning, maintaining or repairing this machine. Place the power cord in a secure location.

- Read and understand the Part Replacement Procedure before working on the machine. Failure to obey the instructions and safety warnings could cause injury to the service technician or bystanders.
- Keep bystanders and children away from the product being serviced at all times.
- Disconnect all power to the machine before you service it.
- Make sure that the repair is done in an appropriate work space away from foot traffic and exposure to bystanders.
- Some components of the equipment can be heavy or awkward. Enlist the service of a second person when you do maintenance steps involving these components. Do not try to do heavy or awkward steps on your own.
- Use only replacement parts and hardware that are supplied or approved by Nautilus. Failure to use Nautilus-approved replacement parts can adversely affect the safety and functionality of the equipment creating a risk to users and will void the warranty.
- Be sure that all warning stickers and instructional placards applied to the product stay present and in good condition when doing maintenance or replacing components. If at any time the Warning labels become loose, unreadable or dislodged, replace the labels. If purchased in US/Canada, contact Customer Service for replacement labels. If purchased outside US/Canada, contact your local distributor for them.
- Do not try to change the design or functionality of the machine being serviced as this can adversely affect user safety.
- Do not use the machine until all shrouds, instructions, warning labels and correct functionality have been verified and tested for correct performance.

• SAVE THESE INSTRUCTIONS

Tools Required (not included)

#2 Phillips screwdriver

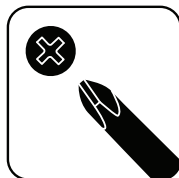

6mm hex wrench

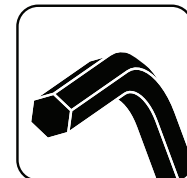

Standard screwdriver



⚠ DANGER

To reduce the risk of electrical shock or unsupervised usage of the equipment, always unplug the power cord from the wall outlet and wait 5 minutes before cleaning, maintaining or repairing this machine. Place the power cord in a secure location.

Note: Your machine may not match the images provided exactly. Though the procedure shows the removal of both Upper Handlebars, only remove one if you are not replacing both Upper Handlebars.

1. Unplug the Power Cord from the wall outlet and machine.

2. Gently compress the Exterior Handlebar Cover to release it from the Interior Handlebar Cover. There are five tabs that snap to secure each Cover.



3. Using a #2 Phillips screwdriver, remove the two screws that attach the Interior Handlebar Cover to the Handlebars. Set the hardware safely aside for reassembly.



4. Using a 6mm hex wrench, remove the four screws that attach the Upper Handlebar to the Lower Handlebar.

5. Slightly pull the Upper Handlebar out of the Lower Handlebar, and disconnect the cables. Set the old Upper Handlebar and hardware safely aside.

NOTICE: Do not cut or pinch the cables. Do not let the cable fall down into the Lower Handlebar. This step may require two people.

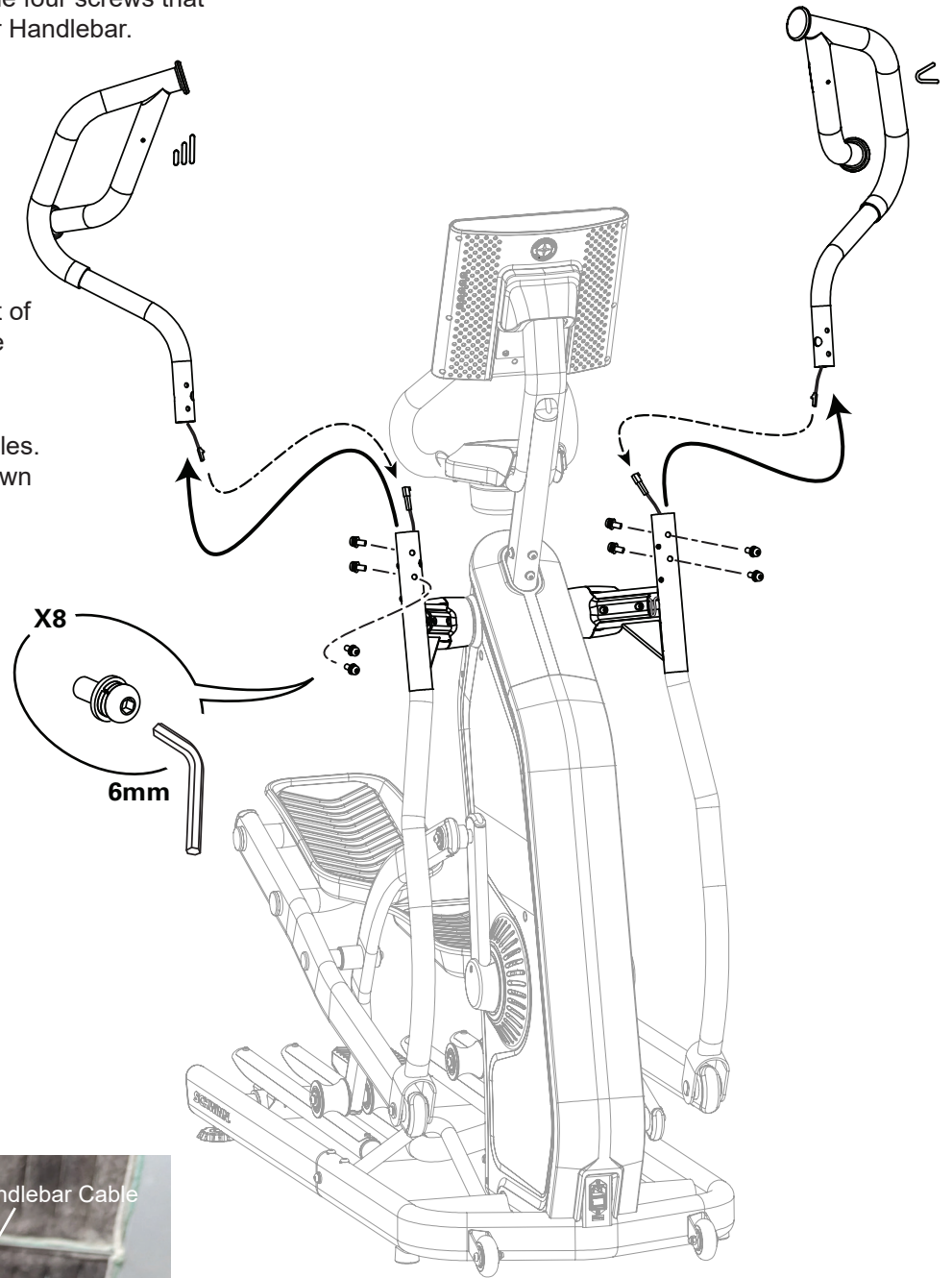

6. Connect the cable from the new Upper Handlebar to the cable from the Lower Handlebar. Align the clips on the cable connectors and make sure the connectors lock. Then safely insert the Upper Handlebar being careful to avoid fingers or hands being caught or pinched.

NOTICE: Do not cut or pinch the cables. This step may require two people.

7. Using a 6mm hex wrench, attach the new Upper Handlebar. Push the extra wire down into the Console Mast.

NOTICE: Do not cut or pinch the cables. When the Upper Handlebar is attached, push the exposed cables back into the Upper Handlebars as far as possible without damaging them.

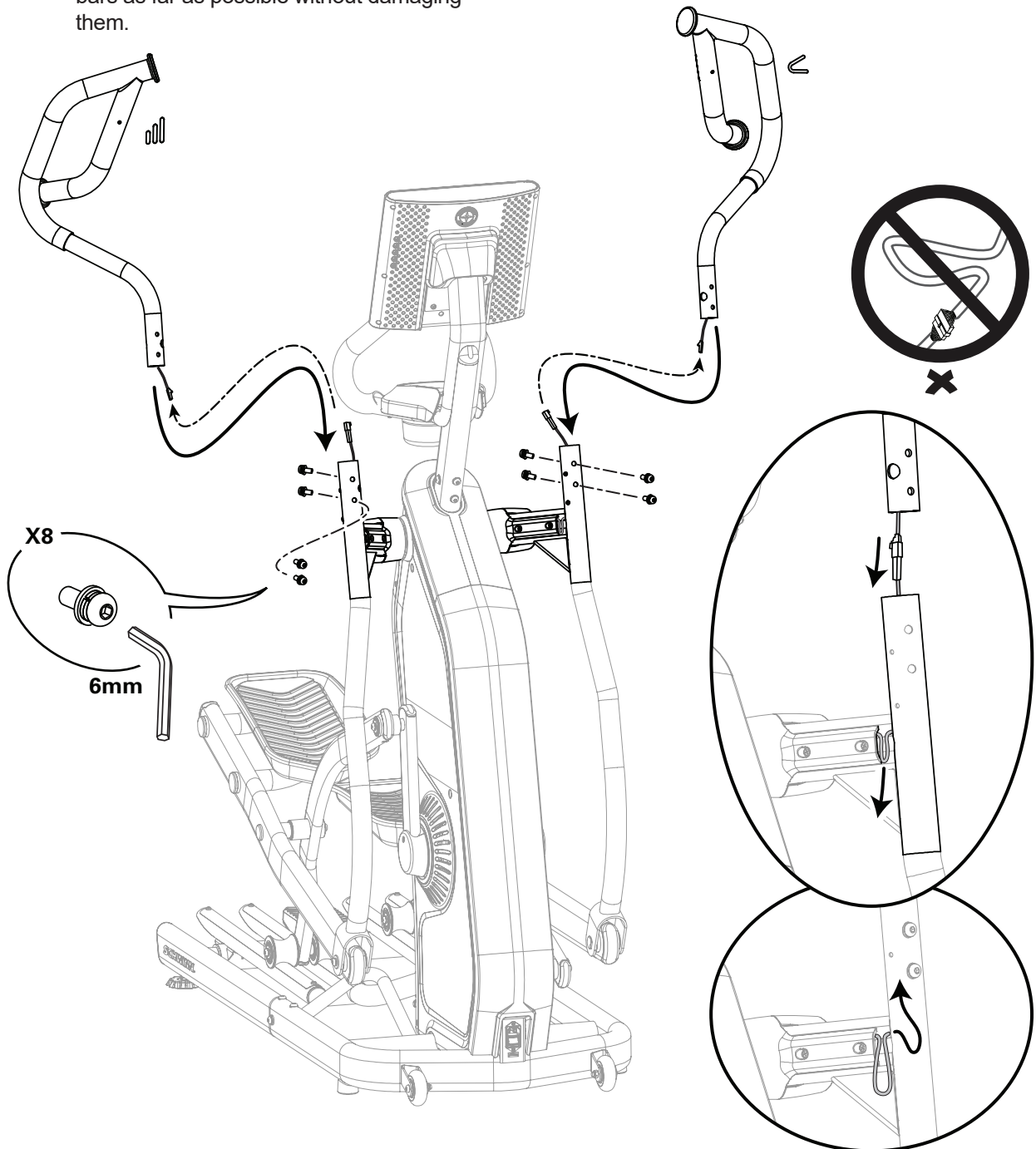

8. Adjust the angle of the Console and tighten the tilting hardware. Then replace the Console Rear Cover on the back of the Console.

9. Re-install all remaining parts that were removed in reverse order.

10. Final Inspection

Inspect your machine to ensure that all hardware is tight and components are properly assembled.

 **Do not use until the machine has been fully assembled and inspected for correct performance in accordance with the Owner's Manual.**