

Table of Contents

Section Code	Section	Page Number
1	Important Safety Instructions	2
1	Safety Warning Labels and Serial Number	3
1	FCC Compliance	3
1	Specifications	4
1	Maintenance	5
1	Moving the Bike	6
1	Leveling the Bike	6
1	Connectivity	7
1	Troubleshooting	8
1	Maintenance Parts Exploded View	10
1	Replacement Procedure Skill Level	11
	Mechanical Procedures	
2	Adjust the Belt Tension	12
3	Set the Brake Tension (Calibration)	18
	Part Replacement	
4	Belt Tensioner Assembly (Idler Assembly)	24
5	Brake Assembly	30
6	Console	36
7	Console Mast	38
8	Data Cable in the Mast	41
9	Drive Belt and Flywheel Assembly	45
10	Drive Pulley (Crank Assembly)	53
11	Heart Rate Cable in the Mast	60
12	Pedals	64
13	Power Inlet	67
14	RPM Sensor (Speed Sensor)	73
15	Seat Rail Assembly	78
16	Servo Motor	83
17	Shrouds	89
18	Transport Wheels	94

NOTICE: This document provides important safety instructions, adjustments, and general troubleshooting information for the maintenance of the Schwinn™ 230 / 510R (Model Year 2020) Recumbent Bikes.

If you need assistance, please contact Customer Service (if purchased in US/Canada) or your local distributor (if purchased outside US/Canada). To find your local distributor, go to: www.nautilusinternational.com

 **This icon means a potentially hazardous situation which, if not avoided, could result in death or serious injury. Read and understand all Warnings on this machine.**

Nautilus, Inc., www.NautilusInc.com, 5415 Centerpoint Parkway, Groveport, OH 43125 U.S.A. - Customer Service: North America (800) 605-3369, csnls@nautilus.com | outside U.S. www.nautilusinternational.com | Printed in China | © 2022 Nautilus, Inc. | Schwinn, Schwinn Toolbox and the Schwinn logo are trademarks owned or licensed by Nautilus, Inc., registered or otherwise protected by common law in the United States and other nations. Google™ is a trademark of their respective owners. App Store is a service mark of Apple Inc. The Bluetooth® word mark and logos are registered trademarks owned by Bluetooth SIG, Inc., and any use of such marks by Nautilus, Inc. is under license. | **ORIGINAL DOCUMENT - ENGLISH VERSION ONLY**

Important Safety Instructions

 **This icon means a potentially hazardous situation which, if not avoided, could result in death or serious injury. Read and understand all Warnings on this machine.**

Before servicing or using this equipment, obey the following warnings:

 **Read and understand the Service Manual before working on the machine. Failure to obey the instructions and safety warnings could cause injury to the service technician or bystanders.**

- Keep bystanders and children away from the product being serviced at all times.
- Make sure that the repair is done in an appropriate work space away from foot traffic and exposure to bystanders.
- Some components of the equipment can be heavy or awkward. Enlist the service of a second person when you do maintenance steps involving these components. Do not try to do heavy or awkward steps on your own.
- If replacement parts are necessary, use only genuine replacement parts and hardware supplied by Nautilus. Failure to use genuine replacement parts can cause a risk to users, keep the machine from operating correctly and void the warranty.
- Be sure that all warning stickers and instructional placards applied to the product stay present and in good condition when doing maintenance or replacing components. If at any time the Warning labels become loose, unreadable or dislodged, replace the labels. If purchased in US/Canada, contact Customer Service for replacement labels. If purchased outside US/Canada, contact your local distributor for them.
- Do not try to change the design or functionality of the machine being serviced as this can adversely affect user safety.
- Do not put the machine back in service until all shrouds, instructions, warning labels and correct functionality have been verified and tested for correct performance.

• SAVE THESE INSTRUCTIONS.

Safety Warning Labels and Serial Numbers

WARNING!

- Injury or death is possible if caution is not used while using this machine.
- Keep children and pets away.
- Read and follow all warnings on this machine.
- Refer to the Owner's Manual for additional warnings and safety information.
- The heart rate displayed is an approximation and should be used for reference only.
- Not intended for use by anyone under 14 years of age.
- The maximum user weight for this machine is 300 lbs (136kg).
- This machine is for home use only.
- Consult a physician prior to using any exercise equipment.

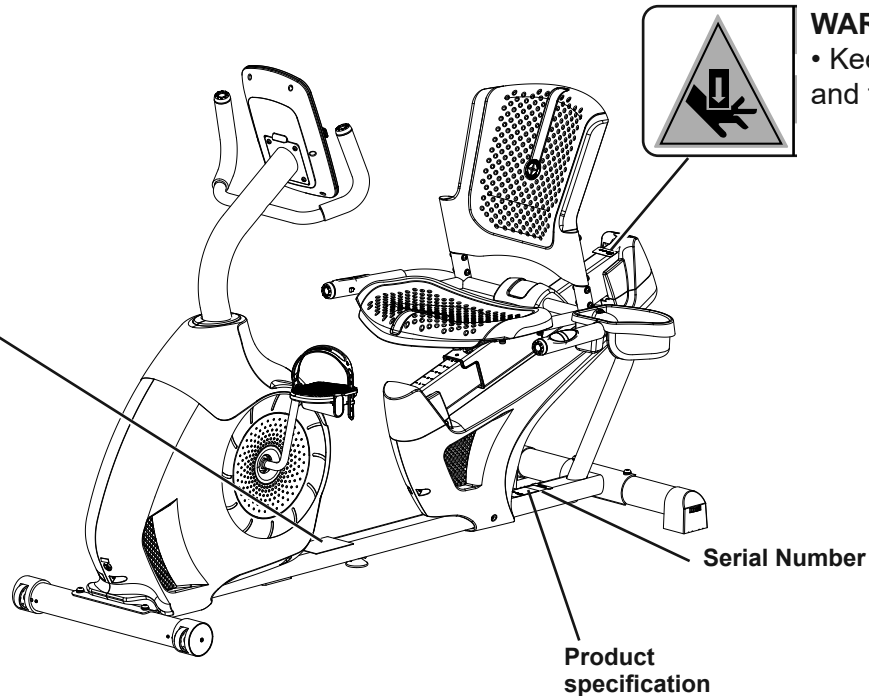

- WARNING!**
- Keep hands and feet away.

(The label on the machine is available in English and French Canadian only.)

FCC Compliance

- ⚠ Changes or modifications to this unit not expressly approved by the party responsible for compliance could void the user's authority to operate the equipment.**

The machine and power supply comply with part 15 of the FCC rules. Operation is subject to the following two conditions: (1) This device may not cause harmful interference, and (2) this device must accept any interference received, including interference that may cause undesired operation.

Note: This machine and power supply have been tested and found to comply with the limits for a Class B digital device, pursuant to Part 15 of the FCC Rules. These limits are designed to provide reasonable protection against harmful interference in a residential installation. This equipment generates, uses and can radiate radio frequency energy and, if not installed and used in accordance with the instructions, may cause harmful interference to radio communications.

However, there is no guarantee that interference will not occur in a particular installation. If this equipment does cause harmful interference to radio or television reception, which can be determined by turning the equipment off and on, the user is encouraged to try to correct the interference by one or more of the following measures:

- Reorient or relocate the receiving antenna.
- Increase the separation between the equipment and receiver.
- Connect the equipment into an outlet on a circuit different from that to which the receiver is connected.
- Consult the dealer or an experienced radio/TV technician for help.

This product complies with the European Radio Equipment Directive 2014/53/EU.

Specifications

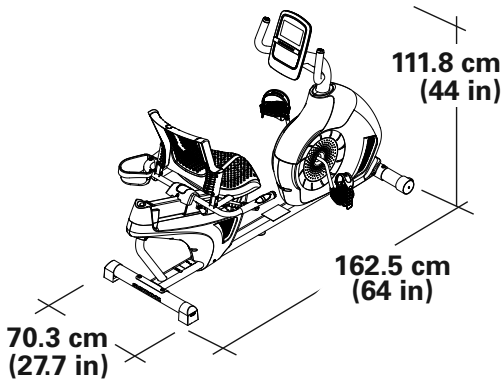

Maximum User Weight: 136 kg (300 lb)
Total Surface Area (footprint) of equipment: 11,423.8 cm²
Machine Weight: 37 kg (81.57 lb)

Power Requirements (AC Adapter):

Input Voltage: 100 - 240V AC, 50/60Hz, 0.4A
Output Voltage: 9VDC, 1.5A



DO NOT dispose of this product as refuse. This product is to be recycled. For proper disposal of this product, please follow the prescribed methods at an approved waste center.

Select the area where you are going to set up and operate your machine. For safe operation, the location must be on a hard, level surface. Allow a workout area of a minimum 1.3 m x 2.2 m (51.3 in x 87.6 in). Keep at least 0.6 m (24 in) along the side used to access the machine and to the rear of the machine clear.

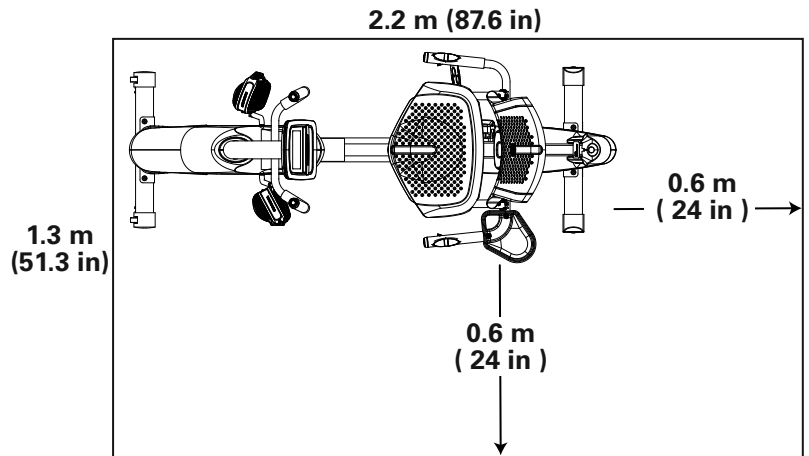

Maintenance

Read all maintenance instructions fully before you start any repair work. In some conditions, an assistant is necessary to do the necessary tasks.

 **Equipment must be regularly examined for damage and repairs. The owner is responsible to make sure that regular maintenance is done. Worn, damaged or loose components must be repaired or replaced immediately. Only manufacturer supplied components can be used to maintain and repair the equipment.**

If at any time the Warning labels become loose, unreadable or dislodged, replace the labels. If purchased in US/Canada, contact Customer Service for replacement labels. If purchased outside US/Canada, contact your local distributor for them.

Disconnect all power to the machine before you service it.

Daily: Before each use, examine the exercise machine for loose, broken, damaged, or worn parts. Do not use if found in this condition. Repair or replace all parts at the first sign of wear or damage. Check Pedals and tighten as necessary. After each workout, use a damp cloth to wipe your machine and Console free of moisture.

Note: Avoid excessive moisture on the Console.

NOTICE: If necessary, only use a mild dish soap with a soft cloth to clean the Console. Do not clean with a petroleum based solvent, automotive cleaner, or any product that contains ammonia. Do not clean the Console in direct sunlight or at high temperatures. Be sure to keep the Console free of moisture.

Weekly: Clean the machine to remove any dust, dirt, or grime from the surfaces. Check pedals and crank arms and tighten as necessary. Check for smooth seat slider operation. If needed, apply a very thin coating of 100% silicone lubricant to ease operation.

 **Silicone lubricant is not intended for human consumption. Keep out of reach of children. Store in a safe place.**

Note: Do not use petroleum based products.

Monthly or after 20 hours: Make sure all bolts and screws are tight. Tighten as necessary.

Moving the Bike

! The machine may be moved by one or more persons depending on their physical abilities and capacities. Make sure that you and others are all physically fit and able to move the machine safely.

1. Remove the power cord.
2. Use the Transport Handle to carefully lift the machine onto the transport rollers.
3. Push the machine into position.
4. Carefully lower the machine into position.

NOTICE: Be careful when you move the bike. Abrupt motions can affect the computer operation.

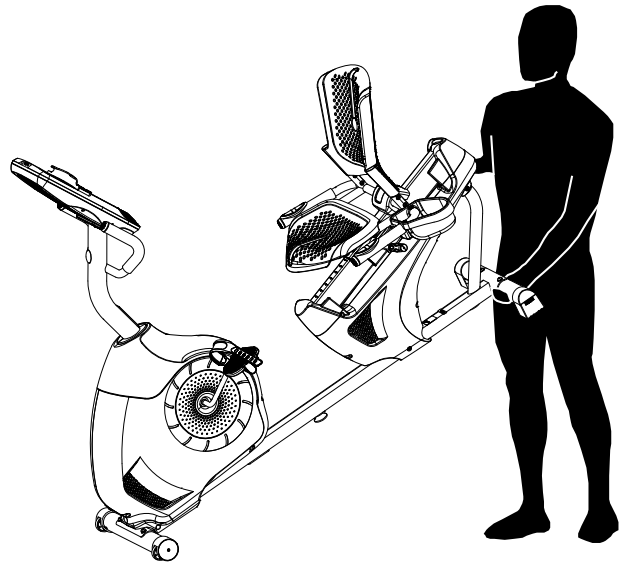

Leveling the Bike

Levelers are found on each side of the Rear Stabilizer and on the Frame Rail. On the Rear Stabilizer, turn the knob to adjust the stabilizer foot.

To adjust the leveler on the Frame Rail:

1. Loosen the upper locking nut.
2. Turn the leveler to adjust the height.

! Do not adjust the levelers to such a height that they detach or unscrew from the machine. Injury to you or damage to the machine can occur.

3. Tighten the upper locking nut to lock the leveler.

Make sure the bike is level and stable before you exercise.

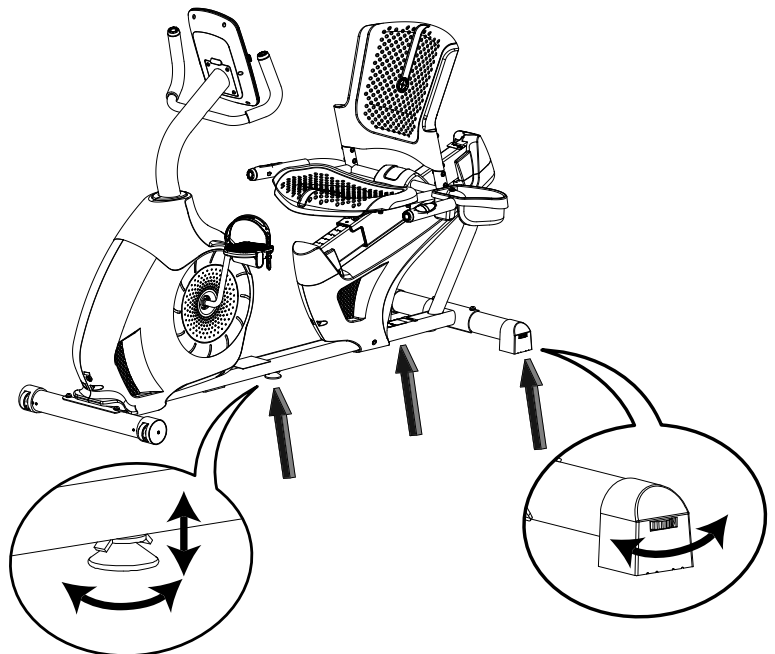

Connectivity

Updates to Your Machine using the “Schwinn Toolbox™” App

This fitness machine is equipped with Bluetooth® connectivity and can be wirelessly updated with the “Schwinn Toolbox™” App. Once the App is installed on your device, the App will inform you of when there is an update to your machine.

1. Download the free App, named Schwinn Toolbox™. The App is available on the App Store and Google Play™.

Note: For a complete list of supported devices, review the App on the App Store or Google Play™.

2. Install the App.

When notified that there is an update to your fitness machine, follow the prompts on the App. Place the device that is running the App on the Media Tray. The App will update the software on the machine with the latest version. Do not remove your device from the Media Tray until the update is complete. The machine will return to the Welcome Screen when the update is completed.

Workout with Other Fitness Apps

This fitness machine has integrated Bluetooth® connectivity which allows it to work with a number of digital partners. For our latest list of supported partners, please visit: www.nautilus.com/partners

Bluetooth® Heart Rate Monitor (not supplied)

Your fitness machine is equipped to be able to receive a signal from a Bluetooth® heart rate (HR) monitor. When connected, the Console will display the Bluetooth® Heart Rate Monitor Connected icon. Follow the instructions provided with your Bluetooth® HR device.

 **If you have a pacemaker or other implanted electronic device, consult your doctor before using a Bluetooth® chest strap or other Bluetooth® heart rate monitor.**

Note: Be sure to remove the protective cover (if provided) from the Heart Rate Sensor before use.

1. Put on your Bluetooth® Heart Rate monitor and activate it.
2. Push the Connect Bluetooth® button. The Console will actively search for any devices in the area. The Bluetooth® Heart Rate Monitor Connected icon will flash on the Console while searching.

Note: Any previously connected HR devices will be disconnected. However, if they are within range, the Console may find them again if unable to locate your Monitor.

3. The Bluetooth® Heart Rate Monitor Connected icon will stop blinking when connected. You are ready to work out.

At the end of your workout, push the Connect Bluetooth® button to disconnect your HR monitor from the Console.

Troubleshooting

Condition/Problem	Things to Check	Solution
No display/partial display/ unit will not turn on	Check electrical (wall) outlet	Make sure unit is plugged into a functioning wall outlet.
	Check connection at front of unit	Connection should be secure and undamaged. Replace adapter or connection at unit if either are damaged.
	Check data cable integrity	All wires in cable should be intact. If any are visibly crimped or cut, replace cable.
	Check data cable connections/orientation	Be sure cables at base of mast and at back of console are connected securely and oriented properly. Small latch on connector should line up and snap into place.
	Check console display for damage	Check for visual sign that console display is cracked or otherwise damaged. Replace Console if damaged.
	Console Display	If Console only has partial display and all connections are fine, replace the Console.
		If the above steps do not resolve the problem, contact Customer Service (if inside US/Canada) or your local distributor (if outside US/Canada).
Unit operates but Contact HR not displayed	HR cable connection at Console and base of mast	Be sure cable is connected securely to Console.
	HR cable box connection	Be sure cables from handlebars and cable to Console are secure and undamaged.
	Sensor grip	Be sure hands are centered on HR sensors. Hands must be kept still with relatively equal pressure applied to each side.
	Dry or calloused hands	Sensors may have difficulty with dried out or calloused hands. A conductive electrode cream (heart rate cream) can help make better conduct. These are available on the web or at medical or some larger fitness stores.
	Static Handlebar	If tests reveal no other issues, Static Handlebar should be replaced.
Unit operates but Bluetooth® HR not displayed	HR monitor (not provided)	Follow the troubleshooting instructions provided with the device.
	HR monitor batteries	If monitor has replaceable batteries, install new batteries.
	Interference	Try moving unit away from sources of interference (TV, Microwave, etc).
	Replace HR monitor	If interference is eliminated and HR does not function, replace HR monitor.
	Replace Console	If HR still does not function, replace Console.
Unit operates but Bluetooth® HR displayed incorrectly	Connected to previous user	The Console may be still connected to the previous user. Push Connect Bluetooth® button to disconnect from them and push again to connect to your device.
No speed/RPM reading, Console displays "Please Pedal" error code	Check data cable integrity	All wires in cable should be intact. If any are cut or crimped, replace cable.
	Check data cable connections/orientation	Be sure each cable is connected securely and oriented properly. Small latch on connector should line up and snap into place.
	Check magnet position (requires shroud removal)	Magnet should be in place on pulley.
	Check Speed Sensor (requires shroud removal)	Speed sensor should be aligned with magnet and connected to data cable. Realign sensor if necessary. Replace if there is any damage to the sensor or the connecting wire.

Condition/Problem	Things to Check	Solution
Resistance does not change (machine turns on and operates)	Check data cable integrity	All wires in cable should be intact. If any are visibly crimped or cut, replace cable.
	Check data cable connections/orientation	Be sure cable is connected securely and oriented properly. Reseat all connections. Small latch on connector should line up and snap into place.
	Check Servo Motor (requires shroud removal)	If magnets move, adjust until they are within the proper range. Replace Servo Motor if not functioning properly.
	Check Console	Check for visual sign that Console is damaged. Replace Console if damaged.
		If the above steps do not resolve the problem, contact Customer Service (if inside US/Canada) or your local distributor (if outside US/Canada) for further assistance.
Console shuts off (enters sleep mode) while in use	Check electrical (wall) outlet	Make sure unit is plugged into a functioning wall outlet.
	Check connection at front of unit	Connection should be secure and undamaged. Replace adapter or connection at unit if either are damaged.
	Check data cable integrity	All wires in the cable should be intact. If any are cut or crimped, replace cable.
	Check data cable connections/orientation	Be sure cable is connected securely and oriented properly. Small latch on connector should line up and snap into place.
	Reset machine	Unplug unit from electrical outlet for 3 minutes. Reconnect to outlet.
	Check magnet position (requires shroud removal)	Magnet should be in place on pulley.
	Check Speed Sensor (requires shroud removal)	Speed sensor should be aligned with magnet and connected to data cable. Realign sensor if necessary. Replace if there is any damage to the sensor or the connecting wire.
Unit rocks/does not sit level	Check leveler adjustment	Adjust levelers until bike is level.
	Check surface under unit	Adjustment may not be able to compensate for extremely uneven surfaces. Move bike to level area.
Pedals loose/unit difficult to pedal	Check pedal to crank arm connection	Pedal should be tightened securely to crank. Insure connection is not cross-threaded.
Clicking sound when pedaling	Check pedal to crank arm connection	Remove pedals. Make sure there is no debris on threads, and reinstall the pedals.
Pedals loose/unit difficult to pedal	Check pedal to crank connection	Pedal should be tightened securely to crank. Be sure connection is not cross threaded.
Seat Assembly shifts / squeaks when in use	Hardware	Check hardware that attaches Seat assembly, and fully tighten hardware.

Maintenance Parts Exploded View

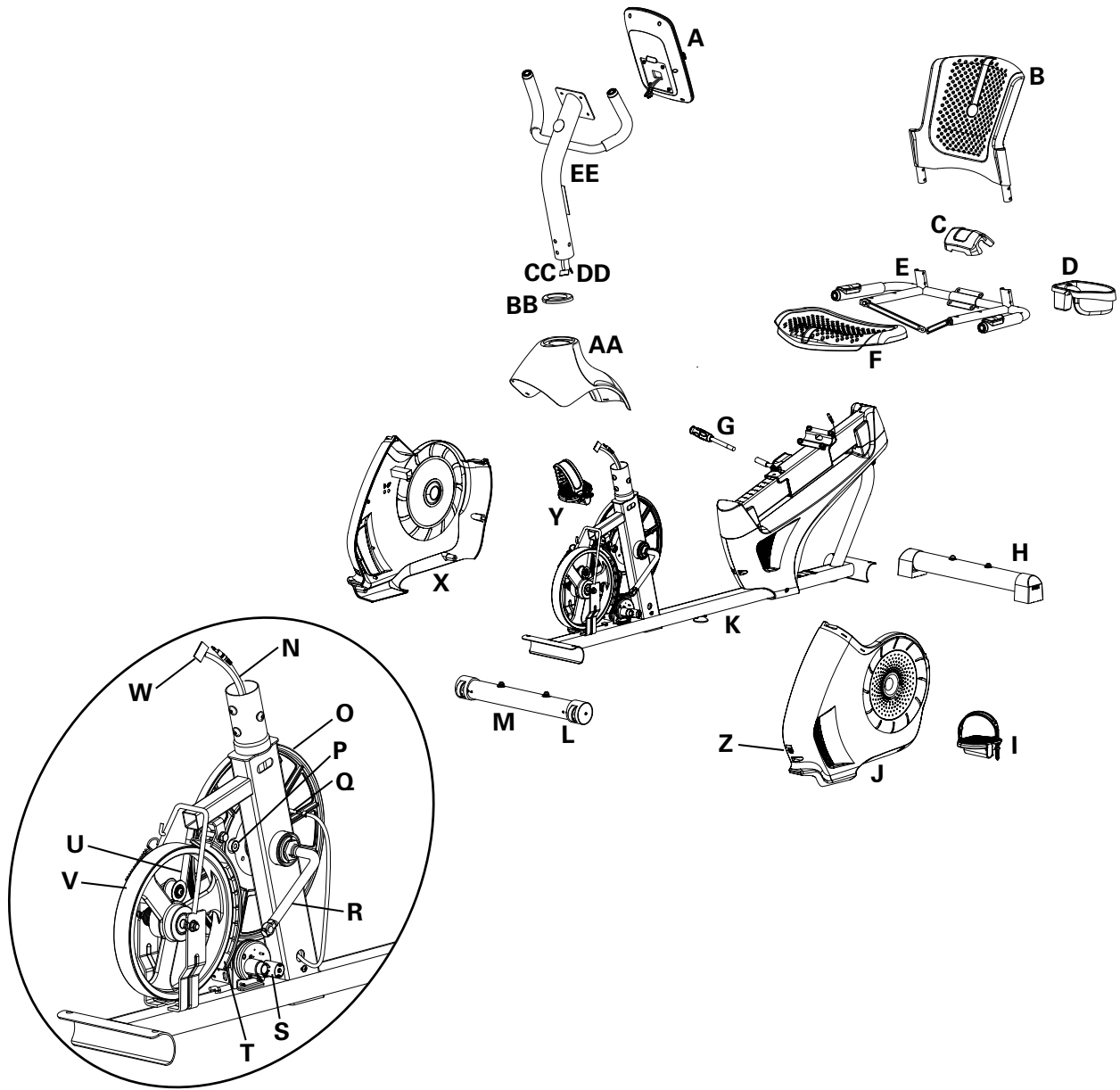

A	Console	L	Transport Wheel	W	Console Cable, Lower
B	Seat Back	M	Stabilizer, Front	X	Shroud, Right
C	Seat Cover	N	Heart Rate Cable, Lower	Y	Pedal, Right
D	Water Bottle Holder	O	Drive Pulley	Z	Power Connector
E	Handlebar, Side	P	Speed Sensor Magnet	AA	Shroud, Upper
F	Seat Bottom	Q	Speed Sensor	BB	Shroud Cap
G	Seat Adjustment Handle	R	Crank Arm	CC	Console Cable, Upper
H	Rear Stabilizer	S	Servo Motor	DD	Heart Rate Cable, Upper
I	Shroud, Left	T	Brake Assembly	EE	Console Mast
J	Pedal, Left	U	Drive Belt		
K	Frame Assembly	V	Flywheel		

REPLACEMENT PROCEDURE SKILL LEVEL

Level I : Low - very little mechanical knowledge or exposure.

Level II : Intermediate - some experience with mechanical procedures

Level III : Advanced - knowledgeable about mechanical procedures



Disconnect all power to the machine before you service it.

When disposing of old parts, obey the applicable local and provincial requirements.

For instructions to replace the following parts, please refer to the Assembly Manual for your bike:

- AC Adapter
- Seat
- Seat Post
- Front Stabilizer
- Rear Stabilizer
- Water Bottle Holder

NOTICE: This document provides instructions for the adjustment of the Drive Belt tension on the Schwinn™ 130 / 510U Upright Bikes and 230 / 510R Recumbent Bikes.

If you need assistance, please contact Customer Service (if purchased in US/Canada) or your local distributor (if purchased outside US/Canada). To find your local distributor, go to: www.nautilusinternational.com

⚠ This icon means a potentially hazardous situation which, if not avoided, could result in death or serious injury. Read and understand all Warnings on this machine.

Nautilus, Inc., www.NautilusInc.com, 5415 Centerpoint Parkway, Groveport, OH 43125 U.S.A. - Customer Service: North America (800) 605-3369, csnls@nautilus.com | outside U.S. www.nautilusinternational.com | Printed in China | © 2022 Nautilus, Inc. | Schwinn and the Schwinn logo are trademarks owned or licensed by Nautilus, Inc., registered or otherwise protected by common law in the United States and other nations. | **ORIGINAL DOCUMENT - ENGLISH VERSION ONLY**

Important Safety Instructions - Before servicing or using this equipment, obey the following warnings:

⚠ This icon means a potentially hazardous situation which, if not avoided, could result in death or serious injury. Read and understand all Warnings on this machine.

Disconnect all power to the machine before you service it.

- Read and understand the Part Replacement Procedure before working on the machine. Failure to obey the instructions and safety warnings could cause injury to the service technician or bystanders.
- Keep bystanders and children away from the product being serviced at all times.
- Make sure that the repair is done in an appropriate work space away from foot traffic and exposure to bystanders.
- Some components of the equipment can be heavy or awkward. Enlist the service of a second person when you do maintenance steps involving these components. Do not try to do heavy or awkward steps on your own.
- If replacement parts are necessary, use only genuine Nautilus replacement parts and hardware. Failure to use genuine replacement parts can cause a risk to users, keep the machine from operating correctly and void the warranty.
- Be sure that all warning stickers and instructional placards applied to the product stay present and in good condition when doing maintenance or replacing components. If at any time the Warning labels become loose, unreadable or dislodged, replace the labels. If purchased in US/Canada, contact Customer Service for replacement labels. If purchased outside US/Canada, contact your local distributor for them.
- Do not try to change the design or functionality of the machine being serviced as this can adversely affect user safety.
- Do not use the machine until all shrouds, instructions, warning labels and correct functionality have been verified and tested for correct performance.

• SAVE THESE INSTRUCTIONS.

Tools Required (not included)

#2 Phillips screwdriver



15mm open end wrench



Small flathead screwdriver



15mm socket and wrench



Pedal wrench or 15mm open end wrench



! Disconnect all power to the machine before you service it.

Note: Your machine may not match the image. For reference only.

1. Loosen and remove the Pedals.

Note: The Left Pedal is reverse-threaded. Orientation is based from a seated position on the bike. The Left Pedal has an "L", the Right Pedal an "R".

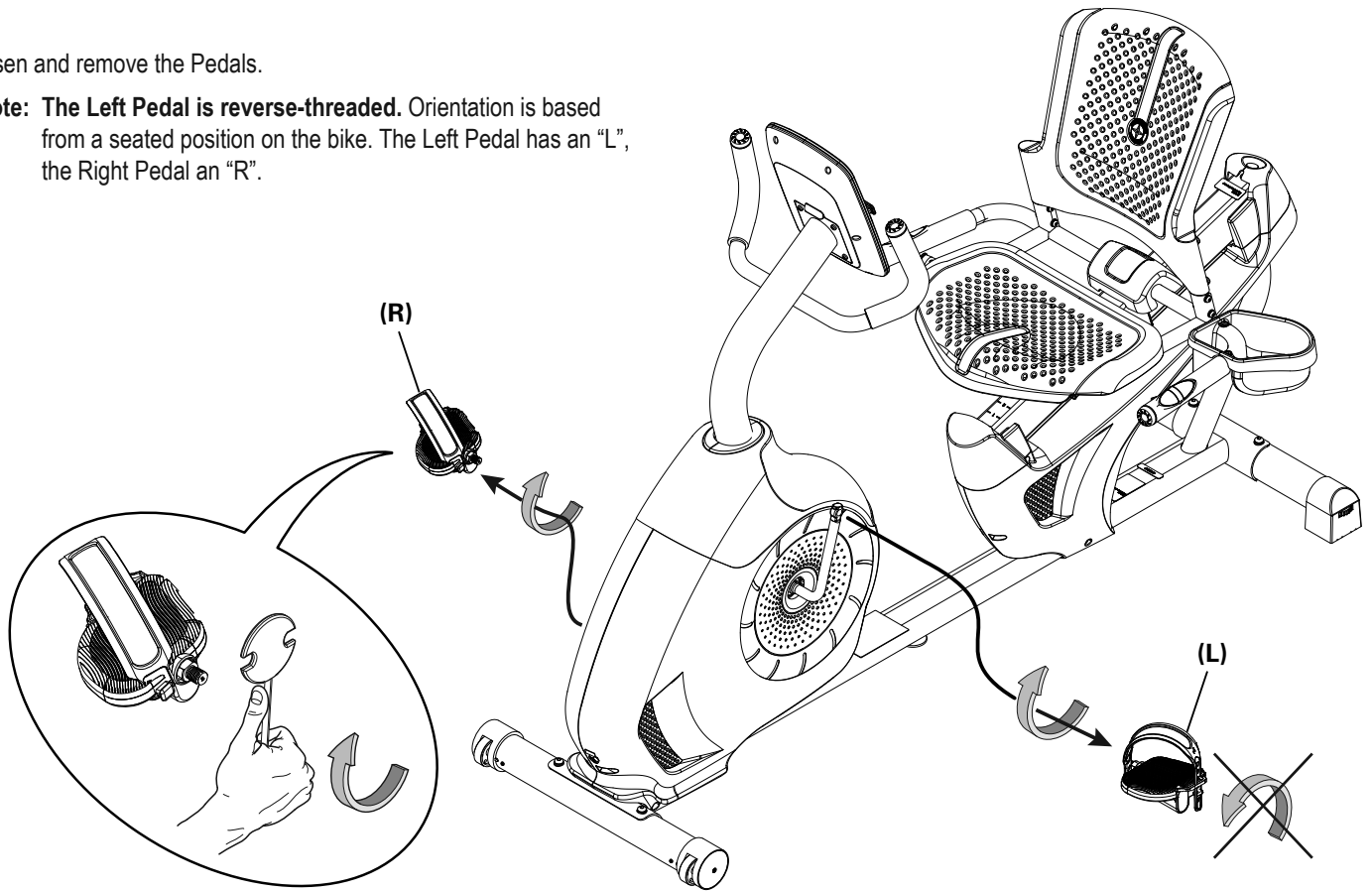

2. Gently remove the Shroud Cap from the Upper Shroud, and remove it from the Console Mast.

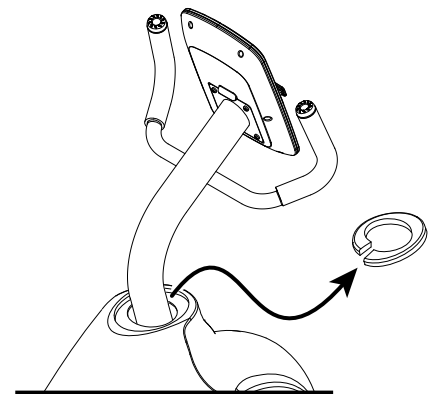

3. Flex the edges of the Upper Shroud to disengage the inside tabs from the Main Assembly, and slide it up the Console Mast.

4. Using a 6mm hex wrench, remove the indicated hardware from the Console Mast. Slightly pull the Console Mast upward, and disconnect the cables. Set the hardware and Upper Shroud safely aside for reassembly. Discard the old Console Mast.

NOTICE: Do not pinch or cut the cables.
This step may require two people.

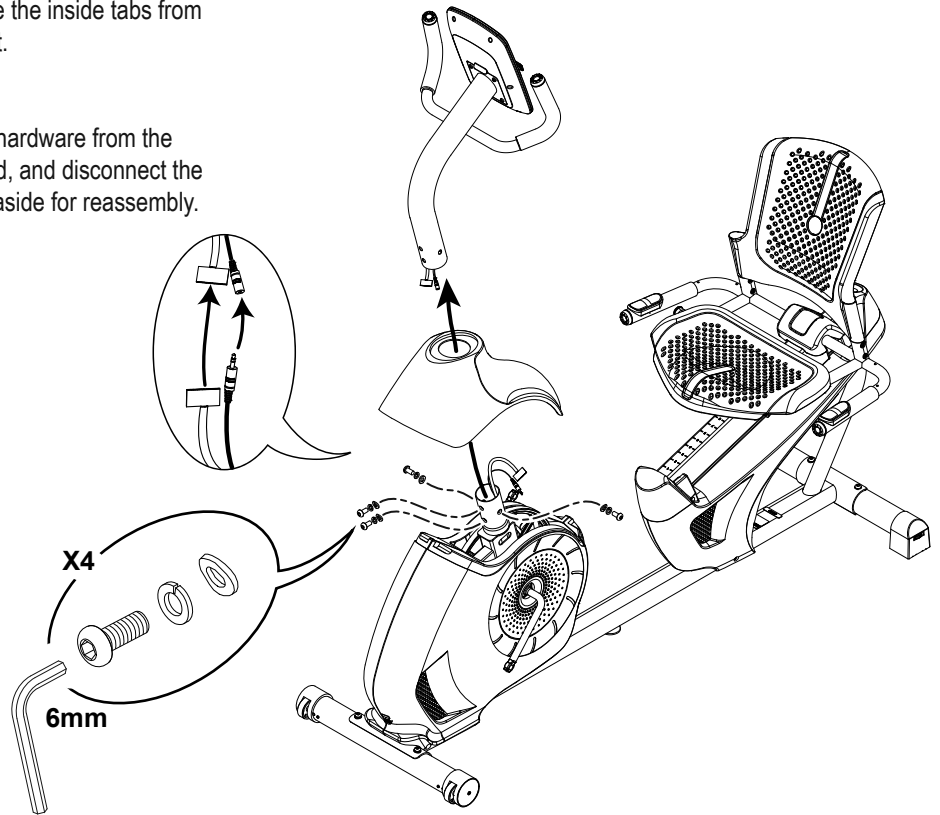

5. Using a #2 Phillips Screwdriver, remove the 6 screws (indicated) that secure the Left Main Shroud. Remove the bottom screws first, and then the top screws. Set the hardware safely aside for reassembly. Slowly remove the Left Main Shroud.

Note: The Power Inlet Cable (A1) is attached to the inside of the Left Main Shroud. Be sure not to pinch or cut the cable by placing the Left Main Shroud close to the side of the machine.

NOTICE: Do not pinch or cut the cables.

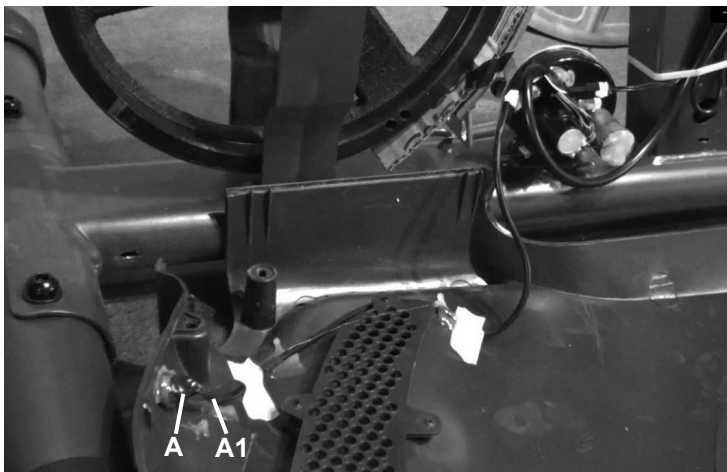
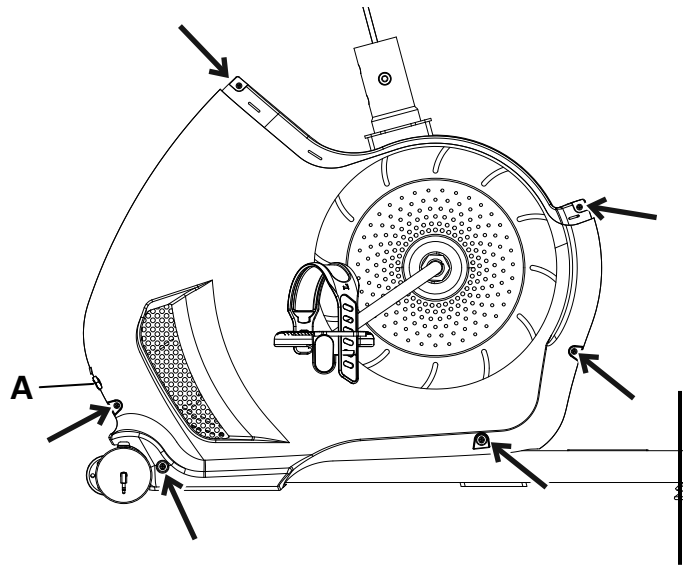

6. Using a #2 Phillips Screwdriver, remove the 2 screws that secure the Right Main Shroud. Slowly remove the Right Main Shroud. Set the hardware and Shroud safely aside for reassembly.

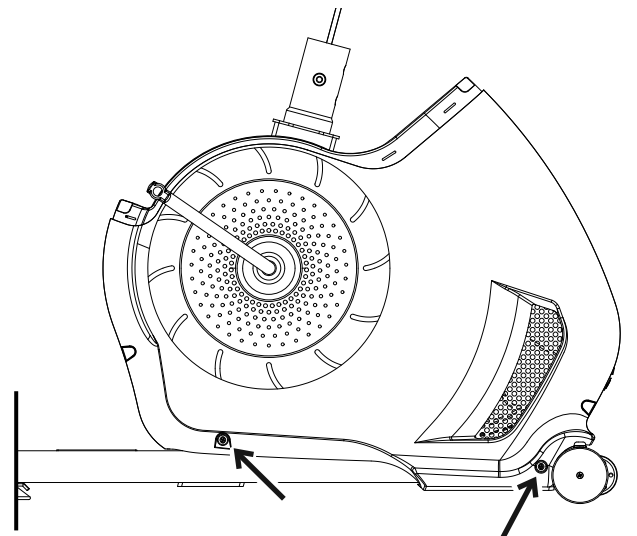

7. To test the Drive Belt tension:

- Push the Drive Belt downward at the midpoint (M) between the pulleys and measure the distance. The Drive Belt should have only 0.25" (0.64cm) of give. See Figure 1.

Or:

- Hold the edges of the Drive Belt at the midpoint (M) and twist it (see Figure 2). It should turn only 90 degrees (1/4 turn, to vertical).

If the tension is correct, go to Step 15.

If the tension is too loose or too tight, adjust the position of the Flywheel.
Continue to the next step.

Figure 1

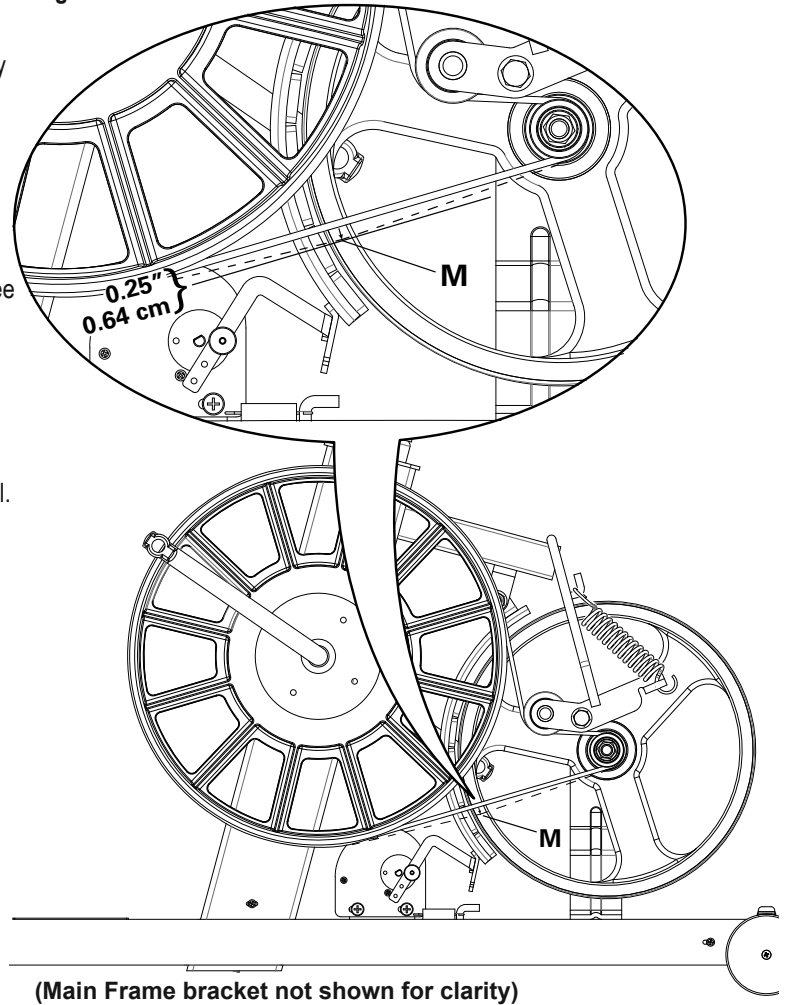
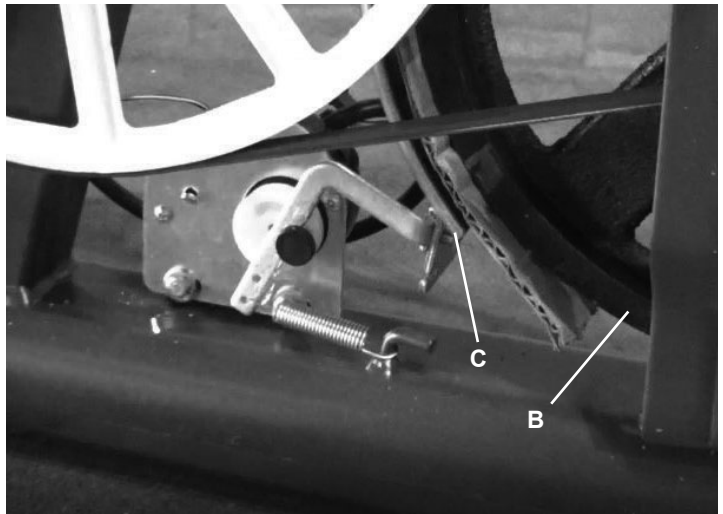

Figure 2



8. Insert 2.5" x 10" cardboard between the Brake Magnet (C) and the Flywheel (B), and tape the cardboard to the Brake Magnet.

Note: Be sure the cardboard covers all of the Brake Magnet.



9. To loosen the Flywheel hardware (D), use a 15mm open end wrench to hold the nut on one side steady and loosen the nut on the opposite side with a 15mm socket and wrench.

10. Move the Flywheel in the Main Frame bracket as necessary to adjust the tension. Hold it in position and tighten the hardware.

Note: This step may require two people.

To tighten the Flywheel hardware, use a 15mm open end wrench to hold the nut on one side steady and tighten the nut on the opposite side with a 15mm socket and wrench.

11. Carefully turn the crank arms and check the movement of the drive belt. The Crank Arms and Flywheel should move as one.

⚠ Be sure to keep fingers clear of all pinch hazards when you turn the Drive Pulley.

Adjust the belt tension again if necessary.

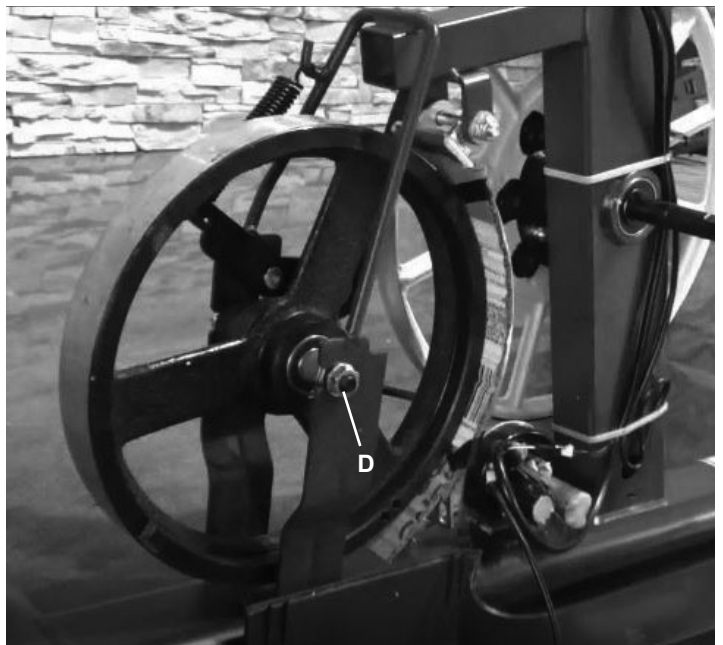

12. Remove the cardboard from the Brake Assembly (if present).

13. Installation is the reverse procedure. Put the Left Shroud in position first to align the screws for the Right Shroud. Install the top screws first.

Note: Self-tapping screws attach the Shrouds to the Frame.

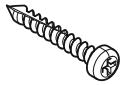

NOTICE: Be sure not to pinch or cut any cables. Be sure the tabs in the Top Shroud snap into the Main Assembly.

14. Attach the Pedals. Start the Pedals by hand, and then fully tighten them with the Pedal Wrench. The Pedals must be fully tightened.

! If the threads strip due to improper installation, then the Pedals can disengage from the bike and/or break while under usage, which can result in serious injury to the user.

Note: The Left Pedal is reverse-threaded. Be sure to attach Pedals on the correct side of the Bike. Orientation is based from a seated position on the bike. The Left Pedal has an "L", the Right Pedal an "R".

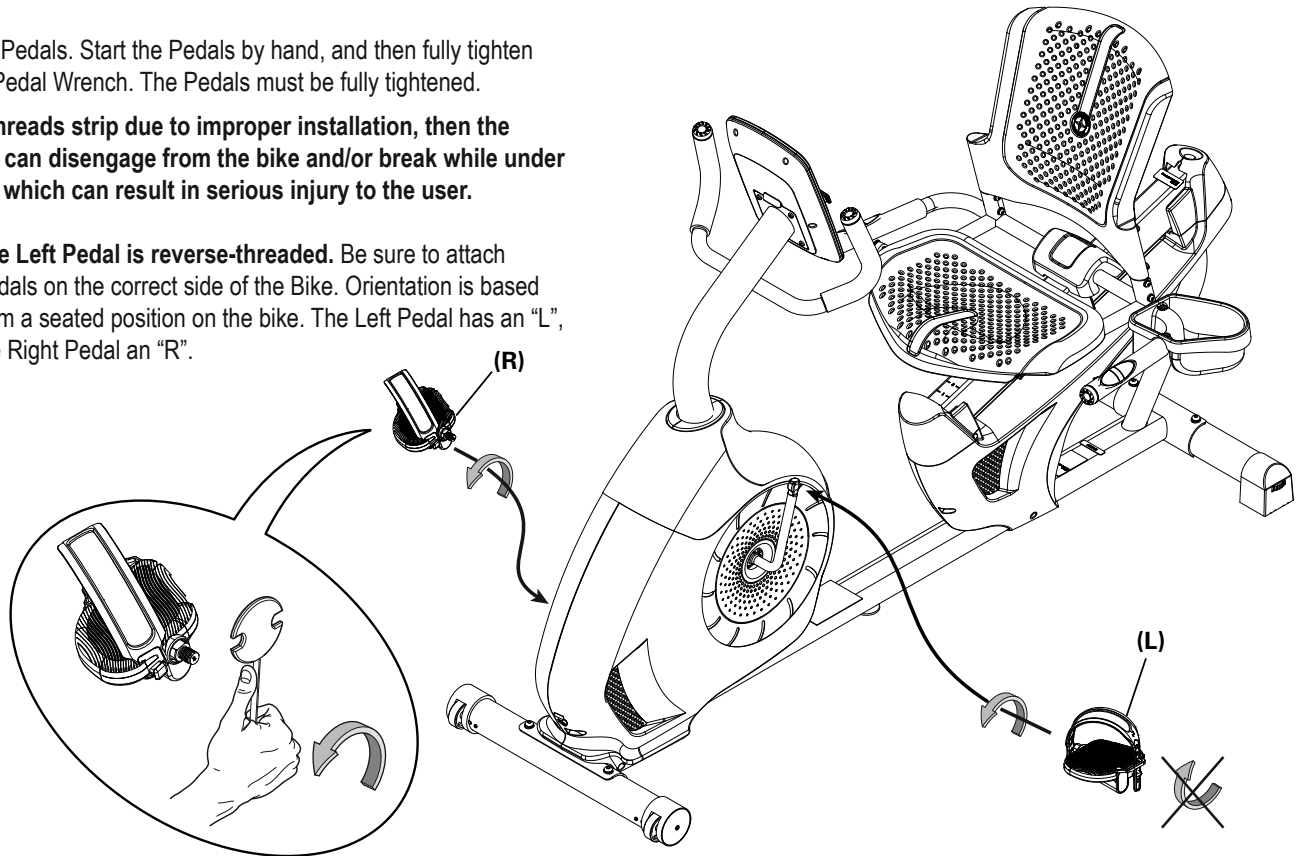

15. Final Inspection

Inspect your machine to ensure that all hardware is tight and components are properly assembled.

! Do not use until the machine has been fully assembled and inspected for correct performance in accordance with the Owner's Manual.

NOTICE: This document provides instructions for the calibration of the Brake tension on the Schwinn™ 230 / 510R Recumbent Bikes.

If you need assistance, please contact Customer Service (if purchased in US/Canada) or your local distributor (if purchased outside US/Canada). To find your local distributor, go to: www.nautilusinternational.com

! This icon means a potentially hazardous situation which, if not avoided, could result in death or serious injury. Read and understand all Warnings on this machine.

Nautilus, Inc., www.NautilusInc.com, 5415 Centerpoint Parkway, Groveport, OH 43125 U.S.A. - Customer Service: North America (800) 605-3369, csnls@nautilus.com | outside U.S. www.nautilusinternational.com | Printed in China | © 2022 Nautilus, Inc. | Schwinn and the Schwinn logo are trademarks owned or licensed by Nautilus, Inc., registered or otherwise protected by common law in the United States and other nations. | **ORIGINAL DOCUMENT - ENGLISH VERSION ONLY**

Important Safety Instructions - Before servicing or using this equipment, obey the following warnings:

! This icon means a potentially hazardous situation which, if not avoided, could result in death or serious injury. Read and understand all Warnings on this machine.

Disconnect all power to the machine before you service it.

- Read and understand the Part Replacement Procedure before working on the machine. Failure to obey the instructions and safety warnings could cause injury to the service technician or bystanders.
- Keep bystanders and children away from the product being serviced at all times.
- Make sure that the repair is done in an appropriate work space away from foot traffic and exposure to bystanders.
- Some components of the equipment can be heavy or awkward. Enlist the service of a second person when you do maintenance steps involving these components. Do not try to do heavy or awkward steps on your own.
- If replacement parts are necessary, use only genuine Nautilus replacement parts and hardware. Failure to use genuine replacement parts can cause a risk to users, keep the machine from operating correctly and void the warranty.
- Be sure that all warning stickers and instructional placards applied to the product stay present and in good condition when doing maintenance or replacing components. If at any time the Warning labels become loose, unreadable or dislodged, replace the labels. If purchased in US/Canada, contact Customer Service for replacement labels. If purchased outside US/Canada, contact your local distributor for them.
- Do not try to change the design or functionality of the machine being serviced as this can adversely affect user safety.
- Do not use the machine until all shrouds, instructions, warning labels and correct functionality have been verified and tested for correct performance.

• SAVE THESE INSTRUCTIONS.

Tools Required (not included)

#2 Phillips screwdriver



7 mm open end wrench



Small flathead screwdriver



2.5" x 10" cardboard (3 mm / 1/8" thick) and tape

Pedal wrench or
15 mm open end wrench



Note: Your machine may not match the image. For reference only.

1. Loosen and remove the Pedals.

Note: The Left Pedal is reverse-threaded. Orientation is based from a seated position on the bike. The Left Pedal has an "L", the Right Pedal an "R".

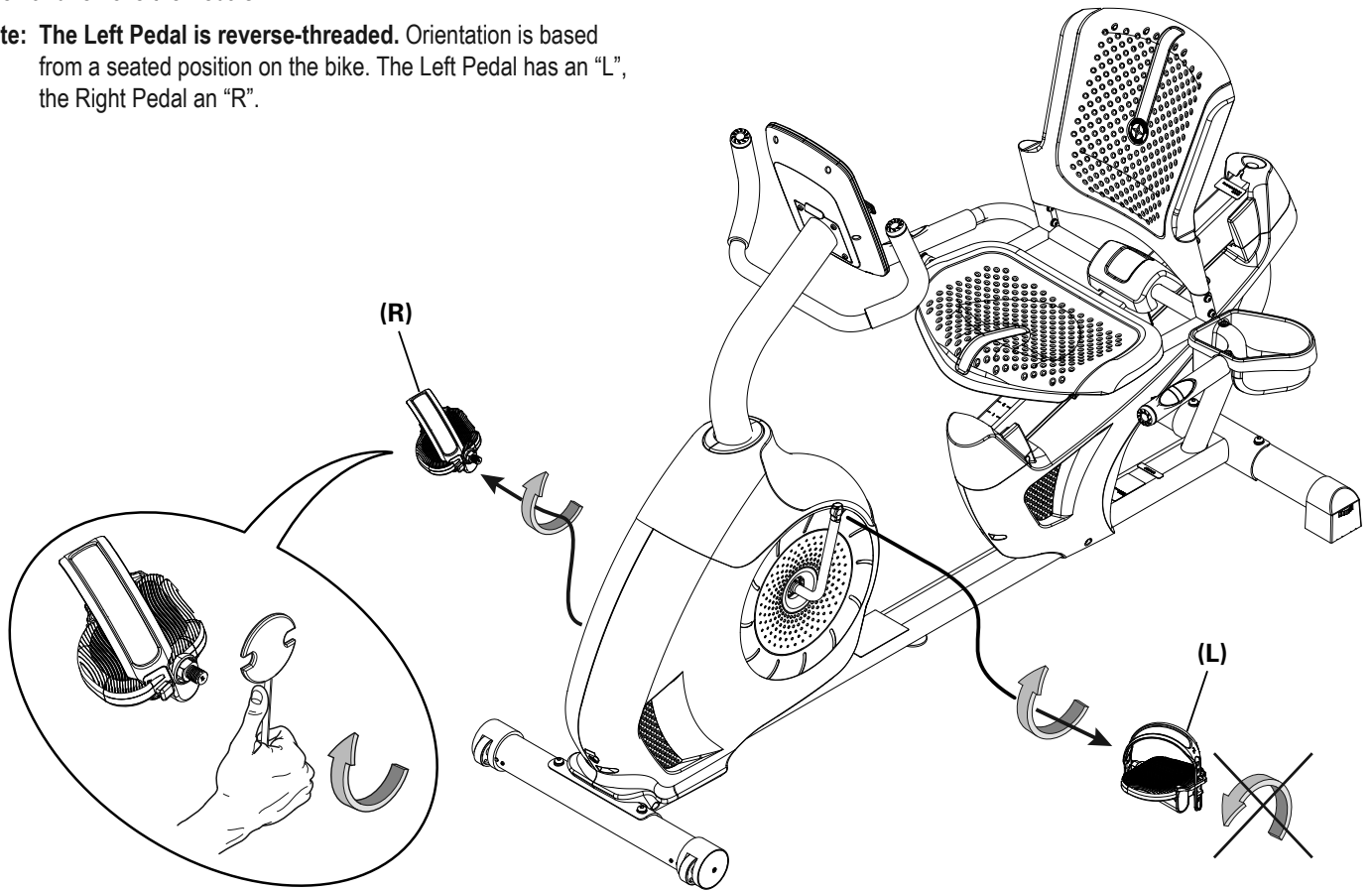

2. Gently remove the Mast Gasket from the Upper Shroud, and remove it from the Console Mast.

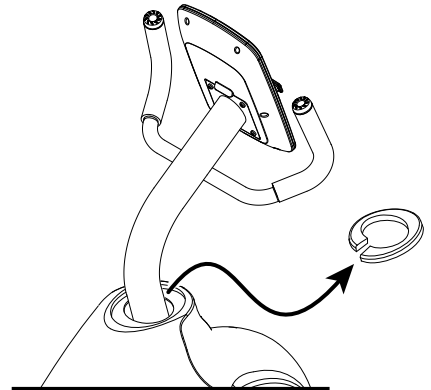

3. Flex the edges of the Upper Shroud to disengage the inside tabs from the Main Assembly, and slide it up the Console Mast.

4. Using a 6mm hex wrench, remove the indicated hardware from the Console Mast. Slightly pull the Console Mast upward, and disconnect the cables. Set the hardware, Shroud Cap, and Upper Shroud safely aside for reassembly. Discard the old Console Mast.

NOTICE: Do not pinch or cut the cables.
This step may require two people.

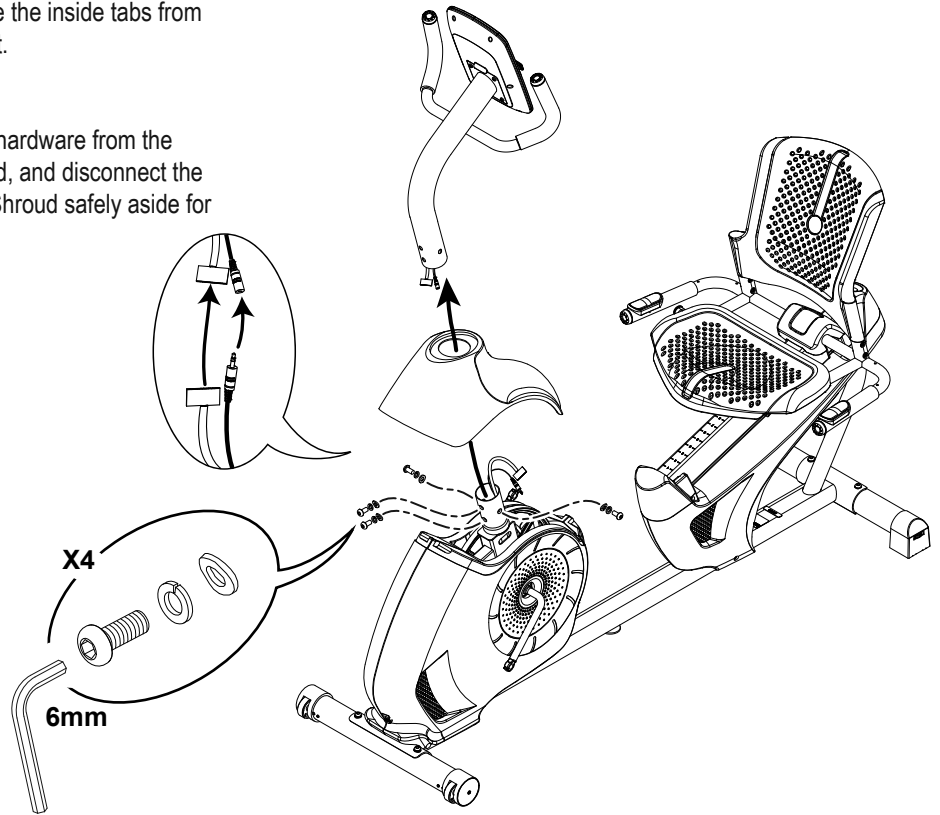

5. Using a #2 Phillips Screwdriver, remove the 6 screws (indicated) that secure the Left Main Shroud. Remove the bottom screws first, and then the top screws. Set the hardware safely aside for reassembly. Slowly remove the Left Main Shroud.

Note: The Power Inlet Cable (A1) is attached to the inside of the Left Main Shroud. Be sure not to pinch or cut the cable by placing the Left Main Shroud close to the side of the machine.

NOTICE: Do not pinch or cut the cables.

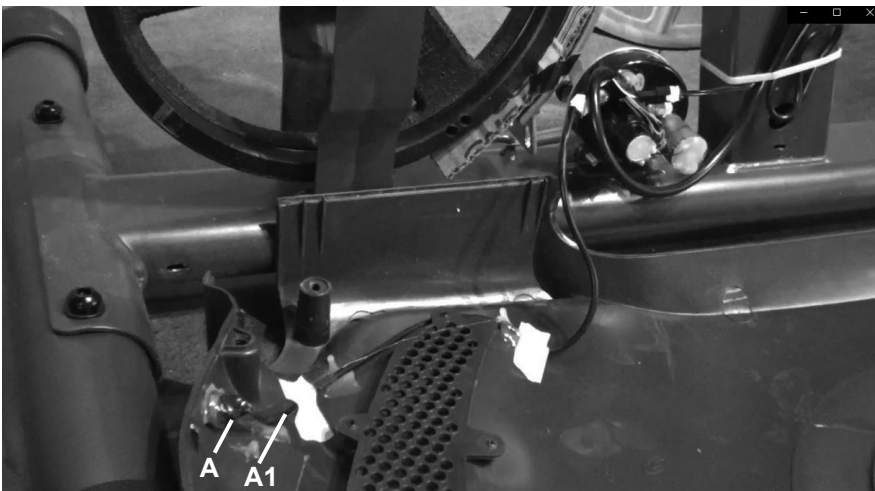
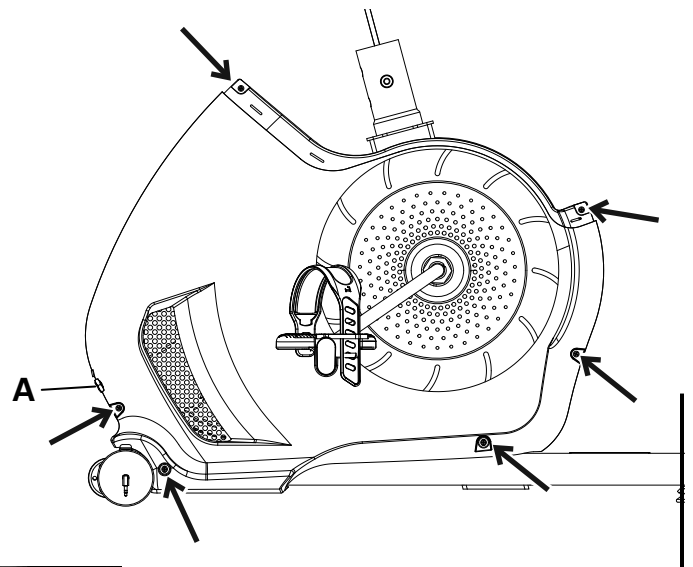

6. Using a #2 Phillips Screwdriver, remove the 2 screws that secure the Right Main Shroud. Slowly remove the Right Main Shroud. Set the hardware and Shroud safely aside for reassembly.

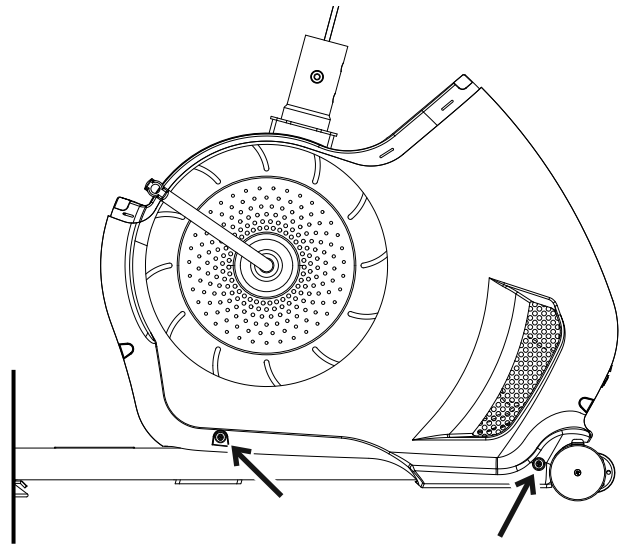

7. Insert 2.5" x 10" cardboard between the Brake Magnet (C) and the Flywheel (B), and tape the cardboard to the Brake Magnet.

Note: Be sure the cardboard covers all of the Brake Magnet.

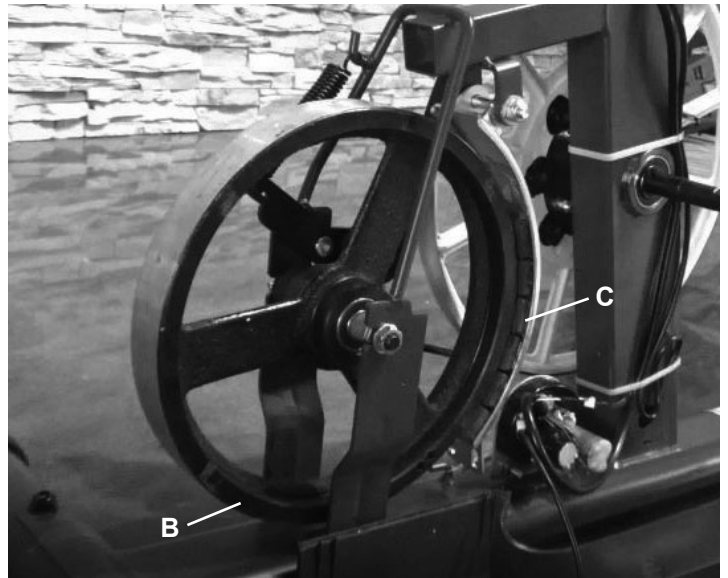

Left side

8. Turn the power on again.

⚠ Machine is on. Current is active. There is risk of electrical shock.

9. Use the console to set the resistance to the highest level. This moves the Brake Magnet Arm (C1) forward. After the Brake Magnet Arm stops at the highest resistance level, turn power off.

⚠ Disconnect all power and allow to sit for 5 minutes.

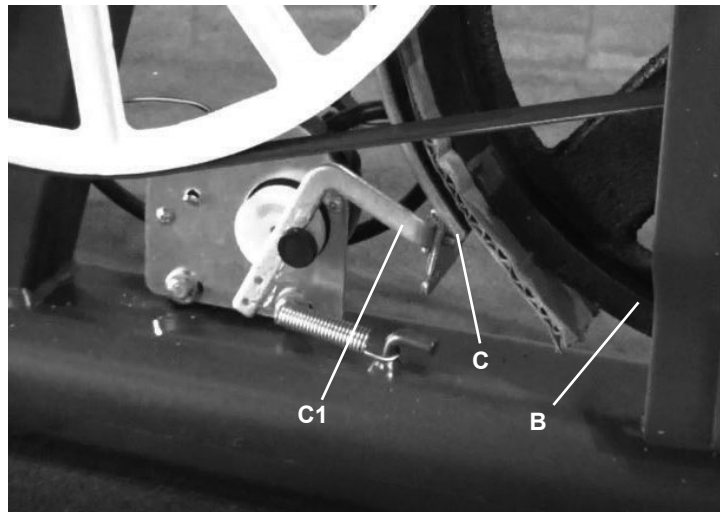

Right side

10. To adjust the Brake tension, loosen the 2 hex head bolts (E) and move the Servo Motor assembly (D) until the closest point on the Brake Magnet (C) is within 3.0 mm (1/8") of the Flywheel (B). Tighten the bolts.

Note: If the cardboard is not 3mm (1/8") thick, you can use the pages of a paperback book to measure the gap. Approximately 36 pages (sheets) = 3mm.

11. Turn the power on again. Use the console to check the resistance adjustment.

⚠ Machine is on. Current is active. There is risk of electrical shock.

Note: Before fully attaching the Shrouds, remove the cardboard from between the Brake Magnet (A) and the Flywheel (B). Power up the machine to verify that the Magnet Arm can move freely, and that the Brake Magnet and Flywheel do not touch.

12. Installation is the reverse procedure. Put the Left Shroud in position first to align the screws for the Right Shroud. Install the top screws first.

Note: Self-tapping screws attach the Shrouds to the Frame.

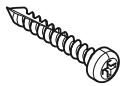

NOTICE: Be sure not to pinch or cut any cables. Be sure the tabs in the Top Shroud snap into the Main Assembly.

13. Attach the Pedals. Start the Pedals by hand, and then fully tighten them with the Pedal Wrench. The Pedals must be fully tightened.

⚠ If the threads strip due to improper installation, then the Pedals can disengage from the bike and/or break while under usage, which can result in serious injury to the user.

Note: The Left Pedal is reverse-threaded. Be sure to attach Pedals on the correct side of the Bike. Orientation is based from a seated position on the bike. The Left Pedal has an "L", the Right Pedal an "R".

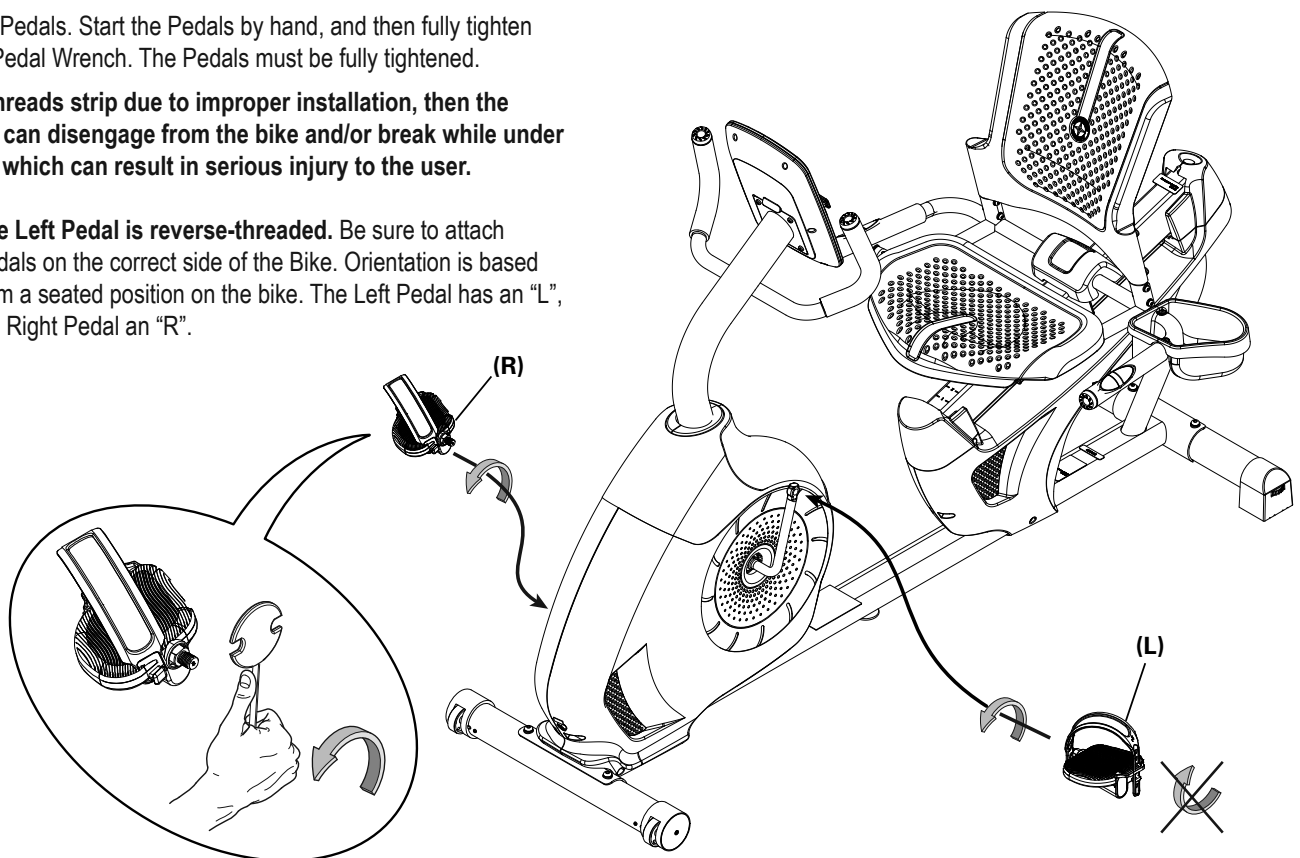
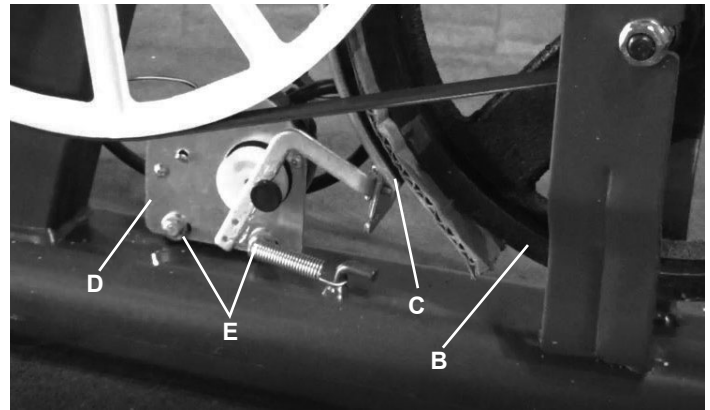

14. Final Inspection

Inspect your machine to ensure that all hardware is tight and components are properly assembled.



Do not use until the machine has been fully assembled and inspected for correct performance in accordance with the Owner's Manual.

NOTICE: This document provides instructions for the replacement of the Belt Tensioner Assembly (Idler Assembly) on the Schwinn™ 130 / 510U Upright Bikes and 230 / 510R Recumbent Bikes.

If you need assistance, please contact Customer Service (if purchased in US/Canada) or your local distributor (if purchased outside US/Canada). To find your local distributor, go to: www.nautilusinternational.com

⚠ This icon means a potentially hazardous situation which, if not avoided, could result in death or serious injury. Read and understand all Warnings on this machine.

Nautilus, Inc., www.NautilusInc.com, 5415 Centerpoint Parkway, Groveport, OH 43125 U.S.A. - Customer Service: North America (800) 605-3369, csnls@nautilus.com | outside U.S. www.nautilusinternational.com | Printed in China | © 2022 Nautilus, Inc. | Schwinn and the Schwinn logo are trademarks owned or licensed by Nautilus, Inc., registered or otherwise protected by common law in the United States and other nations. | **ORIGINAL DOCUMENT - ENGLISH VERSION ONLY**

Important Safety Instructions - Before servicing or using this equipment, obey the following warnings:

⚠ This icon means a potentially hazardous situation which, if not avoided, could result in death or serious injury. Read and understand all Warnings on this machine.

Disconnect all power to the machine before you service it.

- Read and understand the Part Replacement Procedure before working on the machine. Failure to obey the instructions and safety warnings could cause injury to the service technician or bystanders.
- Keep bystanders and children away from the product being serviced at all times.
- Make sure that the repair is done in an appropriate work space away from foot traffic and exposure to bystanders.
- Some components of the equipment can be heavy or awkward. Enlist the service of a second person when you do maintenance steps involving these components. Do not try to do heavy or awkward steps on your own.
- If replacement parts are necessary, use only genuine Nautilus replacement parts and hardware. Failure to use genuine replacement parts can cause a risk to users, keep the machine from operating correctly and void the warranty.
- Be sure that all warning stickers and instructional placards applied to the product stay present and in good condition when doing maintenance or replacing components. If at any time the Warning labels become loose, unreadable or dislodged, replace the labels. If purchased in US/Canada, contact Customer Service for replacement labels. If purchased outside US/Canada, contact your local distributor for them.
- Do not try to change the design or functionality of the machine being serviced as this can adversely affect user safety.
- Do not use the machine until all shrouds, instructions, warning labels and correct functionality have been verified and tested for correct performance.

• SAVE THESE INSTRUCTIONS.

Tools Required (not included)

#2 Phillips screwdriver



Needlenose pliers

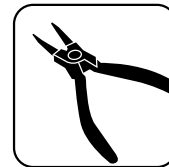

Small flathead screwdriver



13mm open end wrench



Pedal wrench or 15mm open end wrench



Safety goggles or other eye protection

6mm hex wrench



Tape or marking pen



! Disconnect all power to the machine before you service it.

Note: Your machine may not match the image. For reference only.

1. Loosen and remove the Pedals.

Note: The Left Pedal is reverse-threaded. Orientation is based from a seated position on the bike. The Left Pedal has an "L", the Right Pedal an "R".

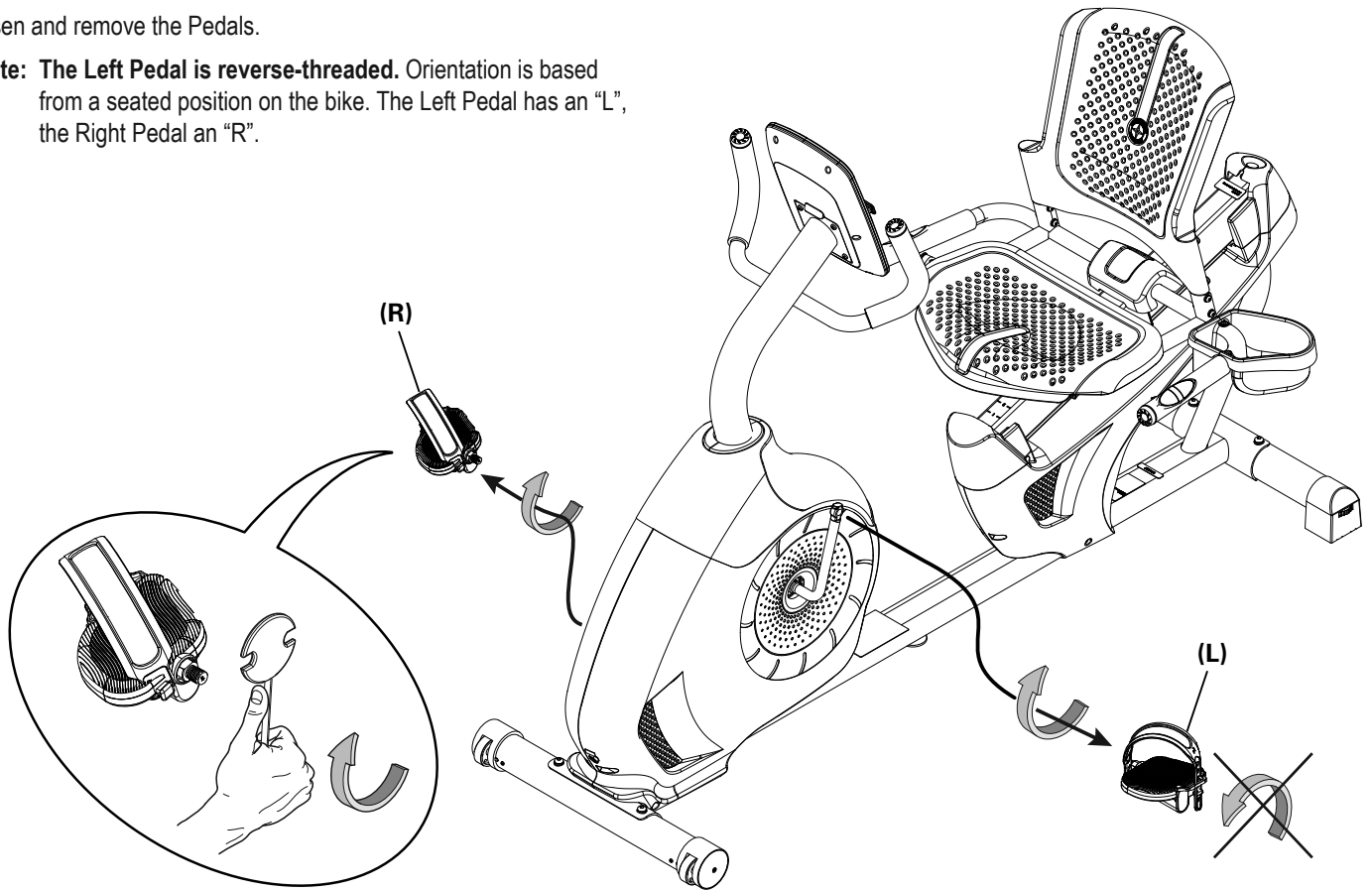

2. Gently remove the Mast Gasket from the Upper Shroud, and remove it from the Console Mast.

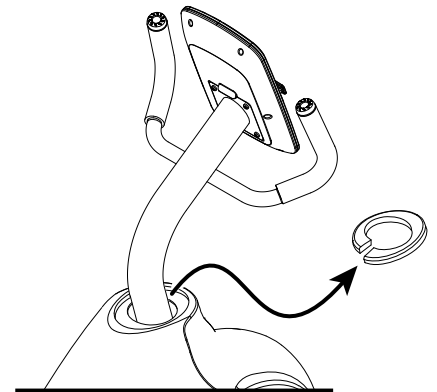

3. Flex the edges of the Upper Shroud to disengage the inside tabs from the Main Assembly, and slide it up the Console Mast.

4. Using a 6mm hex wrench, remove the indicated hardware from the Console Mast. Slightly pull the Console Mast upward, and disconnect the cables. Set the hardware, Shroud Cap, and Upper Shroud safely aside for reassembly. Discard the old Console Mast.

NOTICE: Do not pinch or cut the cables.
This step may require two people.

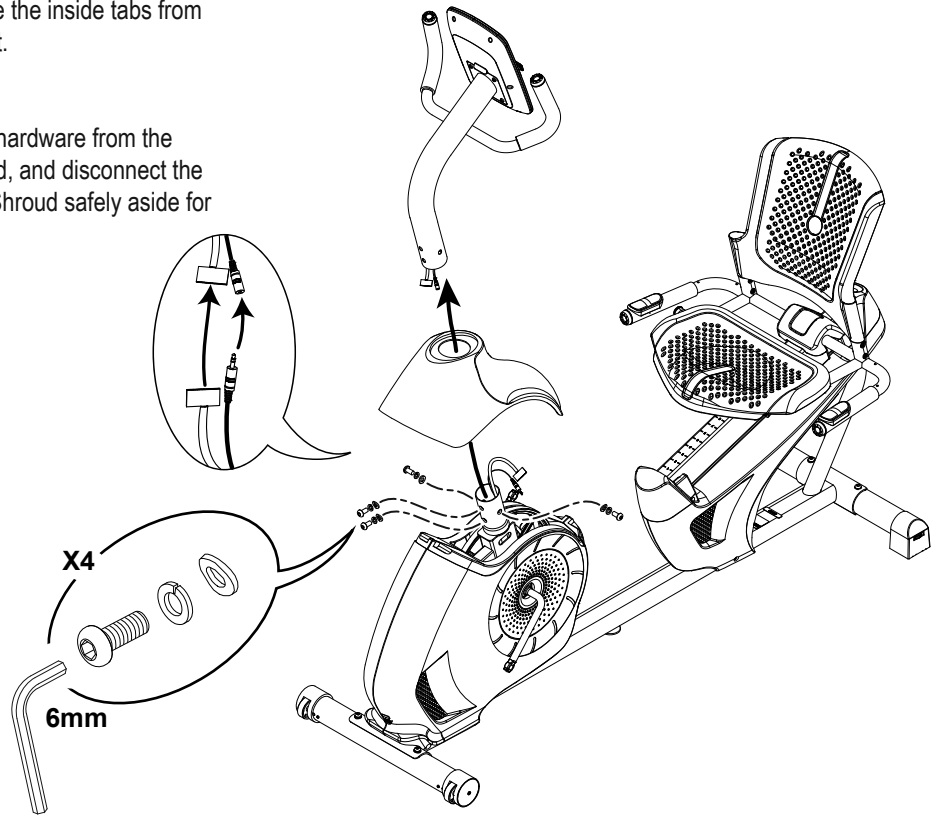

5. Using a #2 Phillips Screwdriver, remove the 6 screws (indicated) that secure the Left Main Shroud. Remove the bottom screws first, and then the top screws. Set the hardware safely aside for reassembly. Slowly remove the Left Main Shroud.

Note: The Power Inlet Cable (A1) is attached to the inside of the Left Main Shroud. Be sure not to pinch or cut the cable by placing the Left Main Shroud close to the side of the machine.

NOTICE: Do not pinch or cut the cables.

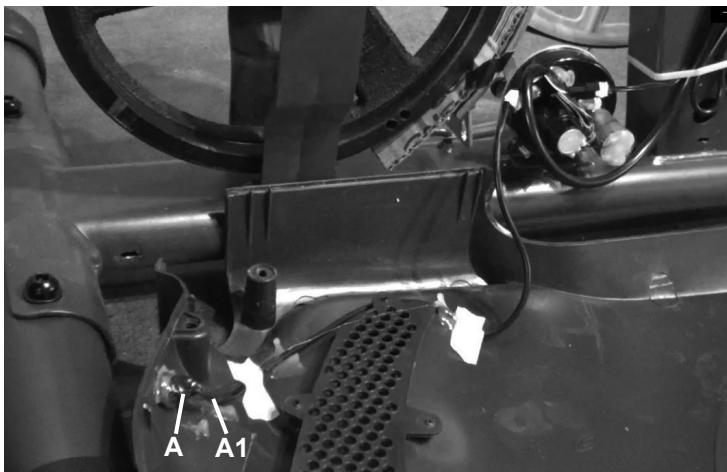
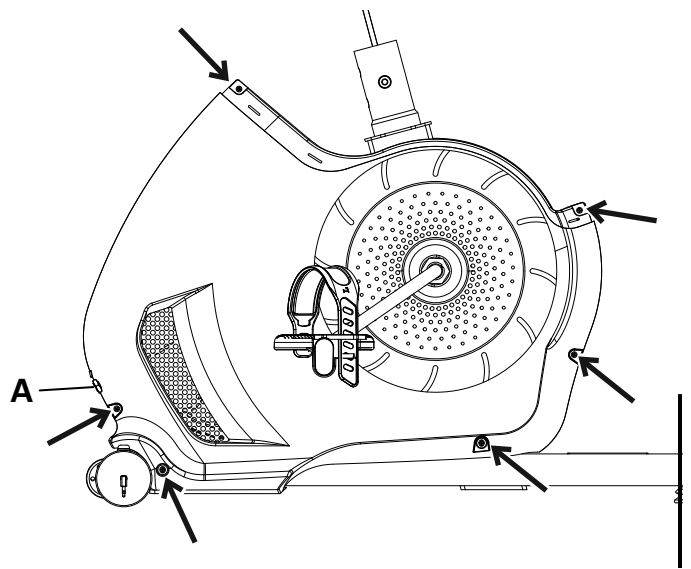

6. Using a #2 Phillips Screwdriver, remove the 2 screws that secure the Right Main Shroud. Slowly remove the Right Main Shroud. Set the hardware and Shroud safely aside for reassembly.

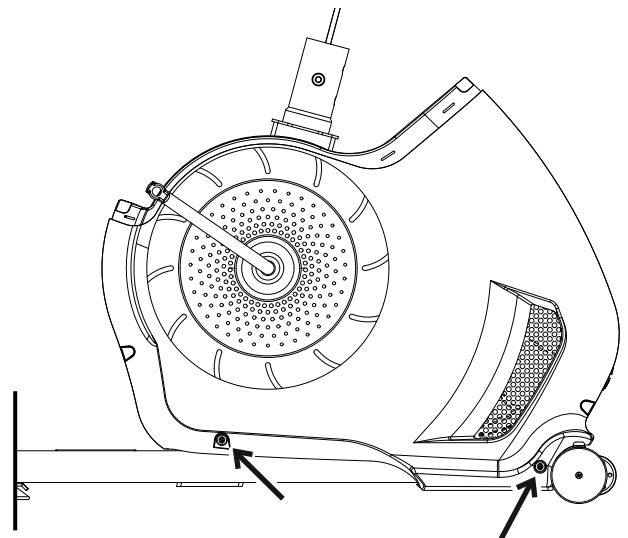

7. Mark the position of the Belt Tensioner (B) on the Main Frame bracket (C) to record the angle of the Tension Spring arm's position.

8. Slowly turn the Drive Pulley (D) backward and carefully ease the Drive Belt (E) off the Drive Pulley to the outside.



Be sure to keep fingers clear of all pinch hazards as you turn the Drive Pulley.

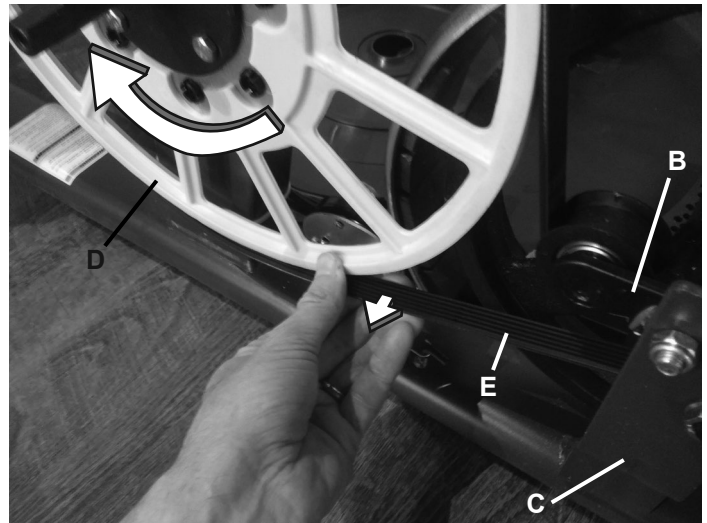

9. Using needlenose pliers, carefully release the spring (F) on the Belt Tensioner (B).

10. Using 13mm wrench and 6mm hex wrench, loosen and remove the Belt Tensioner Hardware (G). Remove the Belt Tensioner assembly (B) from the Main Frame and the Drive Belt (C). Discard the old Belt Tensioner Assembly.

11. Install the new Belt Tensioner Assembly. Adjust the Belt Tensioner position to the angle of the previous position recorded.

NOTICE: Do not overtighten the hardware (G). The Belt Tensioner must be able to pivot. If the hardware is too tight, this can cause wear on the bearings.

12. Put the Drive Belt (E) onto the Drive Pulley (D). Make sure the Drive Belt is aligned on the Flywheel pulley (H1), Belt Tensioner (B) and Drive Pulley (D). Be sure that the upper portion of the Drive Belt is under the bearings on the Belt Tensioner.

13. Using needlenose pliers, attach the Belt Tensioner Spring (F).

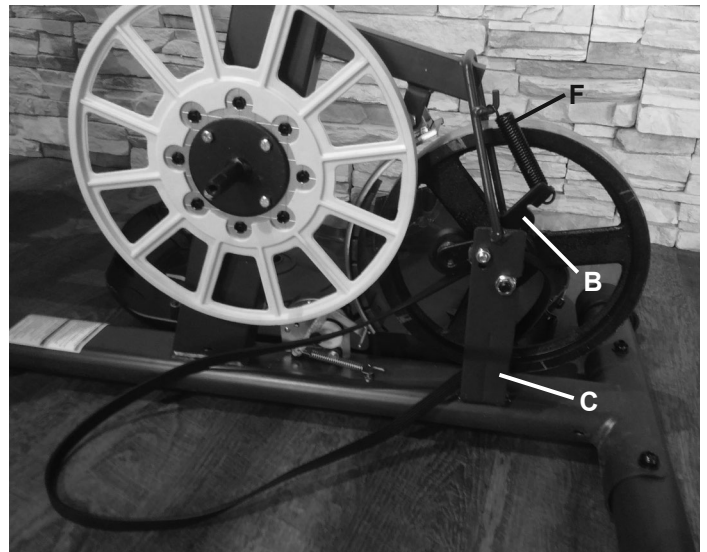

14. Test the Drive Belt tension to be sure that it is correct.

- Push the Drive Belt downward at the midpoint (M) between the pulleys and measure the distance. The Drive Belt should have only 0.25" (0.64cm) of give. See Figure 1.

Or:

- Hold the edges of the Drive Belt at the midpoint (M) and twist it (see Figure 2). It should turn only 90 degrees (1/4 turn, to vertical).

If the tension is correct, go to Step 24.

If the tension is too loose or too tight, adjust the position of the Flywheel. Continue to the next step.

15. To loosen the Flywheel hardware (J), use a 15mm open end wrench to hold the nut on one side steady and loosen the nut on the opposite side with a 15mm socket and wrench.

16. Move the Flywheel in the Main Frame bracket as necessary to adjust the tension. Hold it in position and tighten the hardware.

Note: This step may require two people.

To tighten the Flywheel hardware, use a 15mm open end wrench to hold the nut on one side steady and tighten the nut on the opposite side with a 15mm socket and wrench.

17. Carefully turn the crank arms and check the movement of the drive belt. The Crank Arms and Flywheel should move as one.

⚠ Be sure to keep fingers clear of all pinch hazards when you turn the Drive Pulley.

Adjust the belt tension again if necessary.

Figure 1

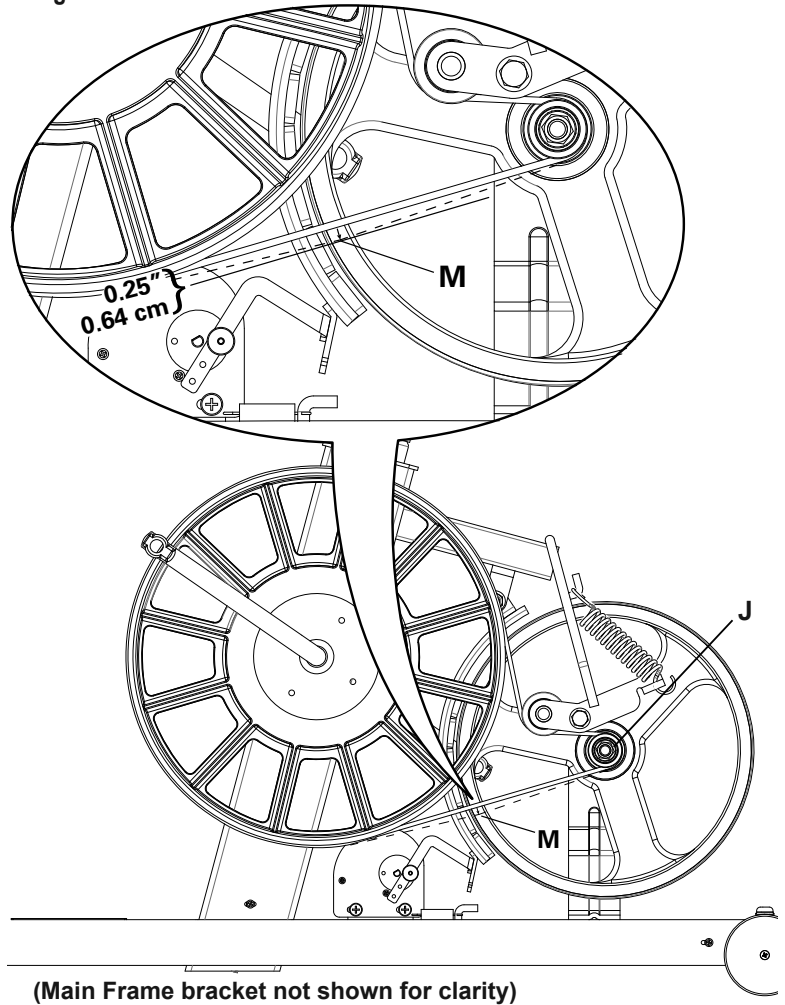
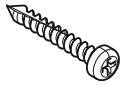

Figure 2



18. Installation is the reverse procedure. Put the Left Shroud in position first to align the screws for the Right Shroud. Install the top screws first.

Note: Self-tapping screws attach the Shrouds to the Frame.



NOTICE: Be sure not to pinch or cut any cables. Be sure the tabs in the Top Shroud snap into the Main Assembly.

19. Attach the Pedals. Start the Pedals by hand, and then fully tighten them with the Pedal Wrench. The Pedals must be fully tightened.

! If the threads strip due to improper installation, then the Pedals can disengage from the bike and/or break while under usage, which can result in serious injury to the user.

Note: The Left Pedal is reverse-threaded. Be sure to attach Pedals on the correct side of the Bike. Orientation is based from a seated position on the bike. The Left Pedal has an "L", the Right Pedal an "R".

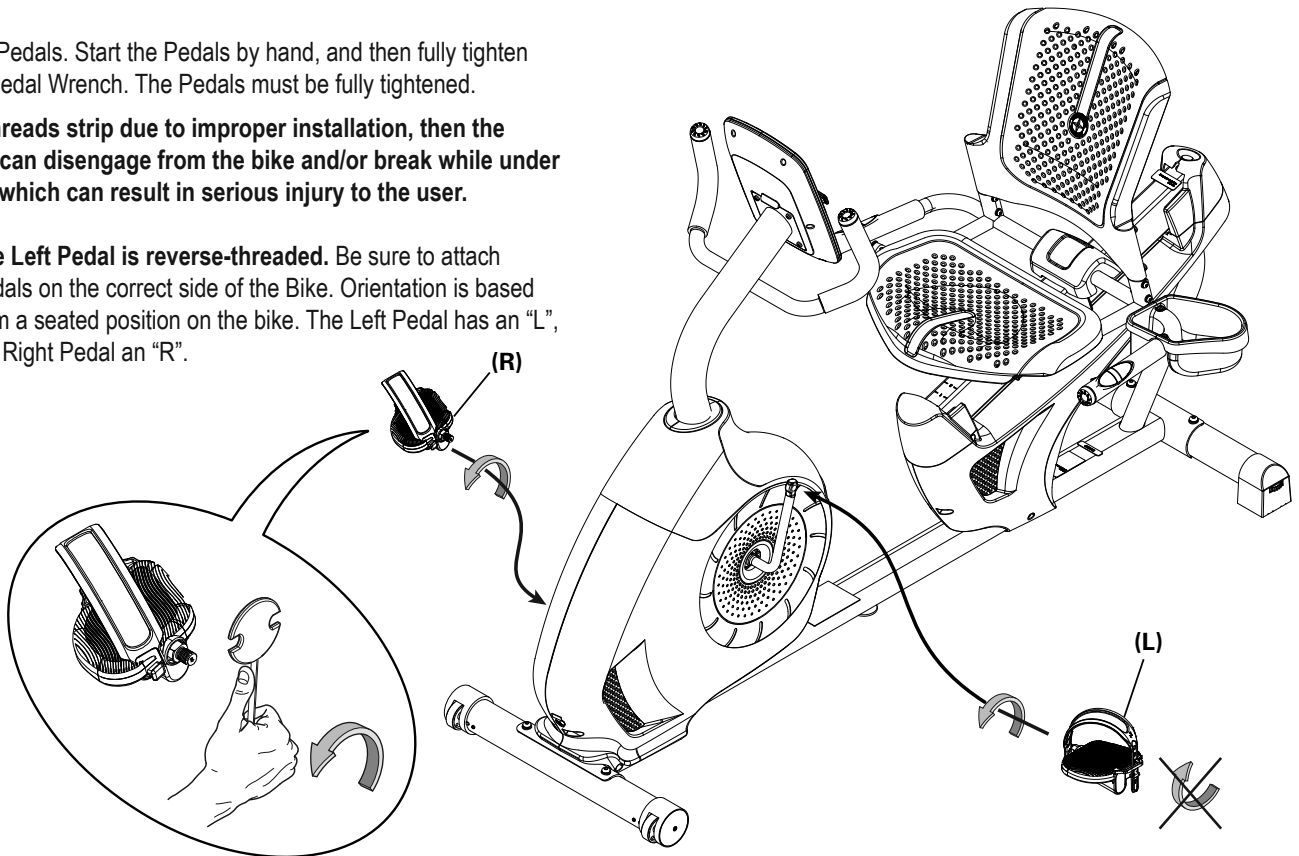

20. Final Inspection

Inspect your machine to ensure that all hardware is tight and components are properly assembled.

! Do not use until the machine has been fully assembled and inspected for correct performance in accordance with the Owner's Manual.

NOTICE: This document provides instructions for the replacement of the Brake Assembly on the Schwinn™ 230 / 510R Recumbent Bikes.

If you need assistance, please contact Customer Service (if purchased in US/Canada) or your local distributor (if purchased outside US/Canada). To find your local distributor, go to: www.nautilusinternational.com

 **This icon means a potentially hazardous situation which, if not avoided, could result in death or serious injury. Read and understand all Warnings on this machine.**

Nautilus, Inc., www.NautilusInc.com, 5415 Centerpoint Parkway, Groveport, OH 43125 U.S.A. - Customer Service: North America (800) 605-3369, csnls@nautilus.com | outside U.S. www.nautilusinternational.com | Printed in China | © 2022 Nautilus, Inc. | Schwinn and the Schwinn logo are trademarks owned or licensed by Nautilus, Inc., registered or otherwise protected by common law in the United States and other nations. | **ORIGINAL DOCUMENT - ENGLISH VERSION ONLY**

Important Safety Instructions - Before servicing or using this equipment, obey the following warnings:

 **This icon means a potentially hazardous situation which, if not avoided, could result in death or serious injury. Read and understand all Warnings on this machine.**

Disconnect all power to the machine before you service it.

- Read and understand the Part Replacement Procedure before working on the machine. Failure to obey the instructions and safety warnings could cause injury to the service technician or bystanders.
- Keep bystanders and children away from the product being serviced at all times.
- Make sure that the repair is done in an appropriate work space away from foot traffic and exposure to bystanders.
- Some components of the equipment can be heavy or awkward. Enlist the service of a second person when you do maintenance steps involving these components. Do not try to do heavy or awkward steps on your own.
- If replacement parts are necessary, use only genuine Nautilus replacement parts and hardware. Failure to use genuine replacement parts can cause a risk to users, keep the machine from operating correctly and void the warranty.
- Be sure that all warning stickers and instructional placards applied to the product stay present and in good condition when doing maintenance or replacing components. If at any time the Warning labels become loose, unreadable or dislodged, replace the labels. If purchased in US/Canada, contact Customer Service for replacement labels. If purchased outside US/Canada, contact your local distributor for them.
- Do not try to change the design or functionality of the machine being serviced as this can adversely affect user safety.
- Do not use the machine until all shrouds, instructions, warning labels and correct functionality have been verified and tested for correct performance.

• SAVE THESE INSTRUCTIONS.

Tools Required (not included)

#2 Phillips screwdriver



Needlenose pliers



Small flathead screwdriver



13mm open end wrench



Pedal wrench or 15mm open end wrench



2.5" x 10" cardboard and tape



! Disconnect all power to the machine before you service it.

Note: Your machine may not match the image. For reference only.

1. Loosen and remove the Pedals.

Note: The Left Pedal is reverse-threaded. Orientation is based from a seated position on the bike. The Left Pedal has an "L", the Right Pedal an "R".

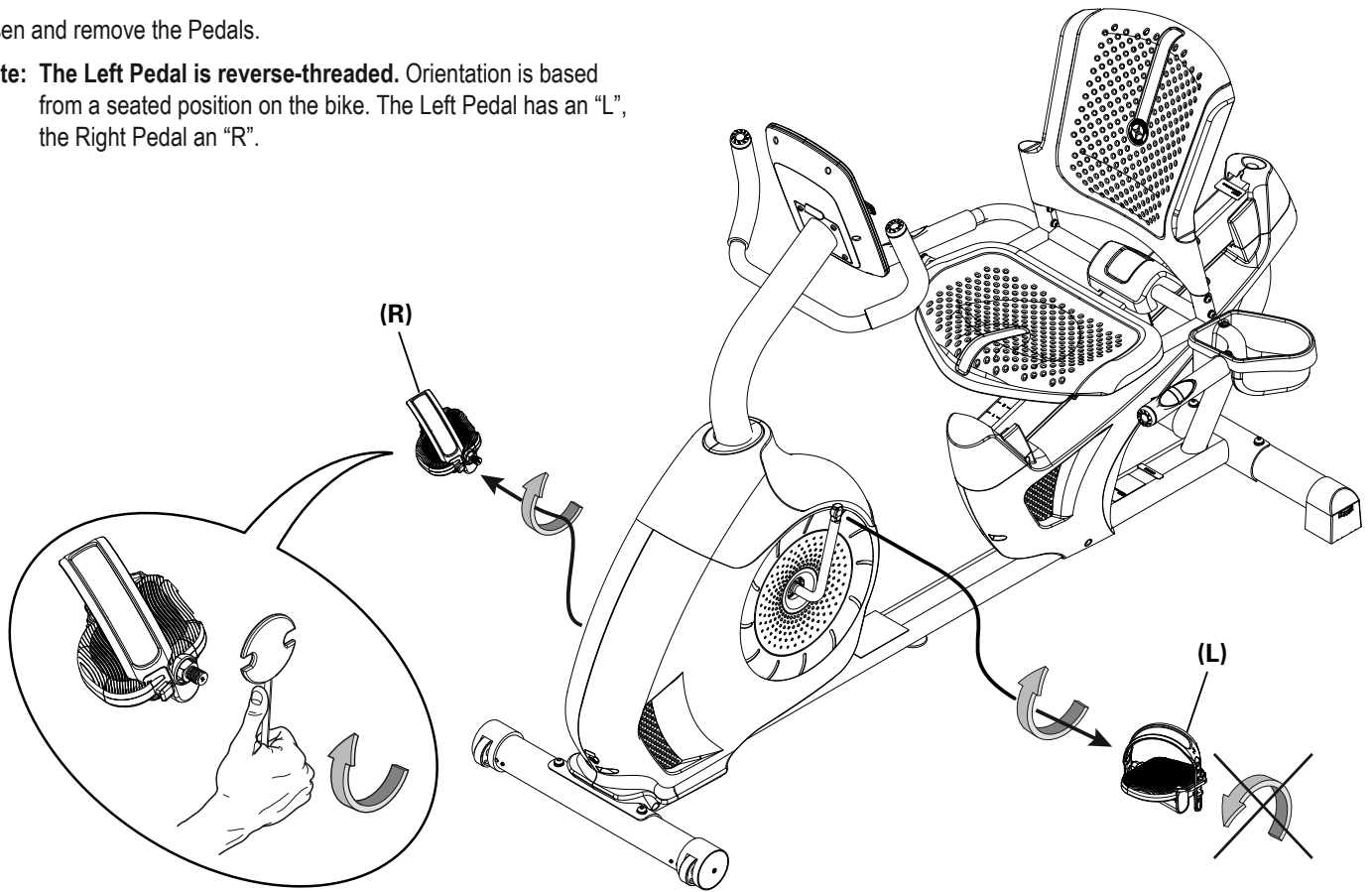

2. Gently remove the Mast Gasket from the Upper Shroud, and remove it from the Console Mast.

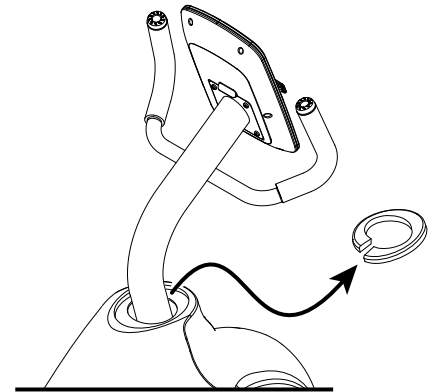

3. Flex the edges of the Upper Shroud to disengage the inside tabs from the Main Assembly, and slide it up the Console Mast.

4. Using a 6mm hex wrench, remove the indicated hardware from the Console Mast. Slightly pull the Console Mast upward, and disconnect the cables. Set the hardware, Shroud Cap, and Upper Shroud safely aside for reassembly. Discard the old Console Mast.

NOTICE: Do not pinch or cut the cables.
This step may require two people.

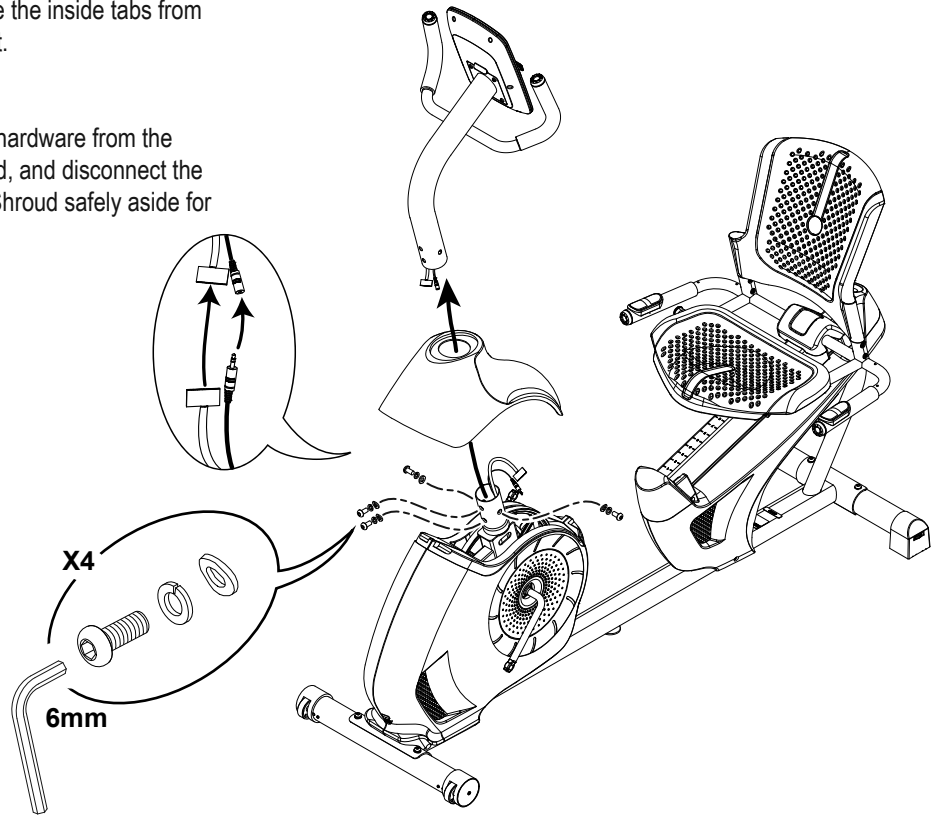

5. Using a #2 Phillips Screwdriver, remove the 6 screws (indicated) that secure the Left Main Shroud. Remove the bottom screws first, and then the top screws. Set the hardware safely aside for reassembly. Slowly remove the Left Main Shroud.

Note: The Power Inlet Cable (A1) is attached to the inside of the Left Main Shroud. Be sure not to pinch or cut the cable by placing the Left Main Shroud close to the side of the machine.

NOTICE: Do not pinch or cut the cables.

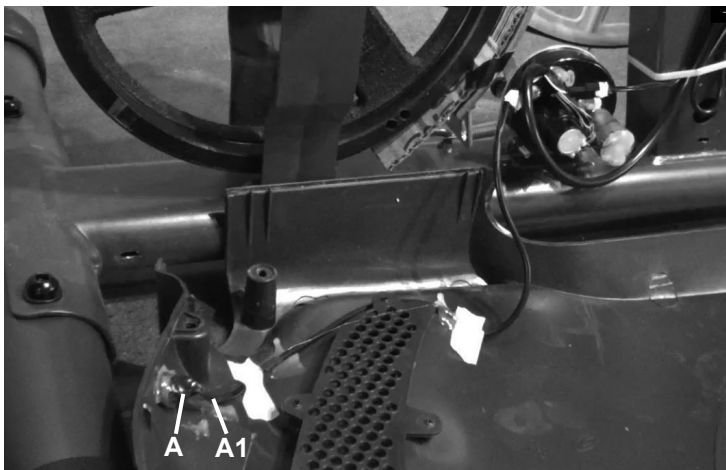
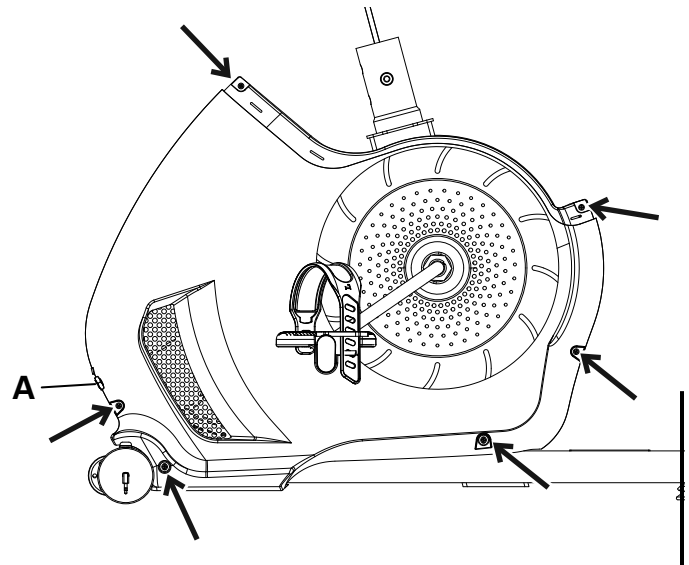

6. Using a #2 Phillips Screwdriver, remove the 2 screws that secure the Right Main Shroud. Slowly remove the Right Main Shroud. Set the hardware and Shroud safely aside for reassembly.

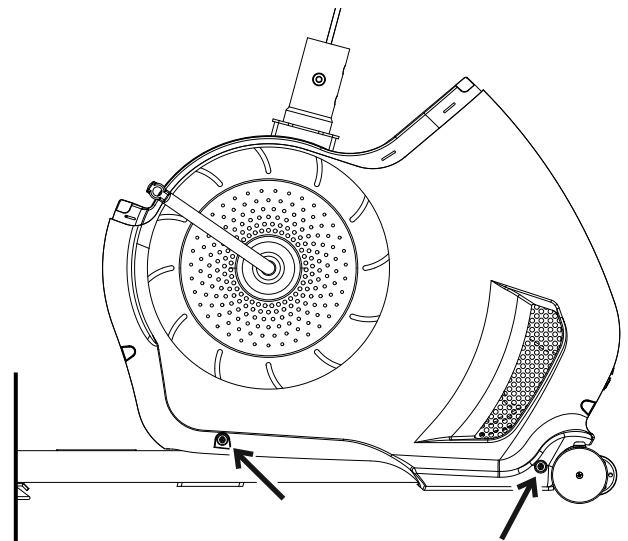

7. Insert 2.5" x 10" cardboard between the Brake Magnet (C) and the Flywheel (B), and tape the cardboard to the Brake Magnet.

Note: Be sure the cardboard covers all of the Brake Magnet.

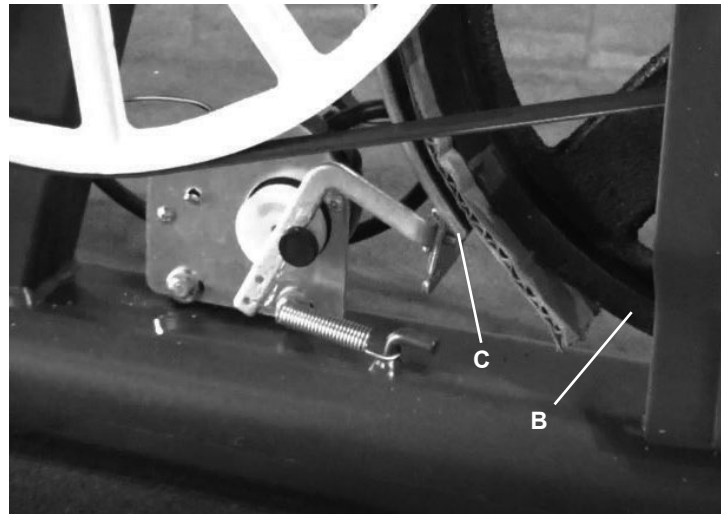

8. Use the pliers to unhook the Tension Spring (F) from the Main Frame. Pull back and release the Magnet Arm (D) enough to disengage it from the Motor Pulley Shaft (E).

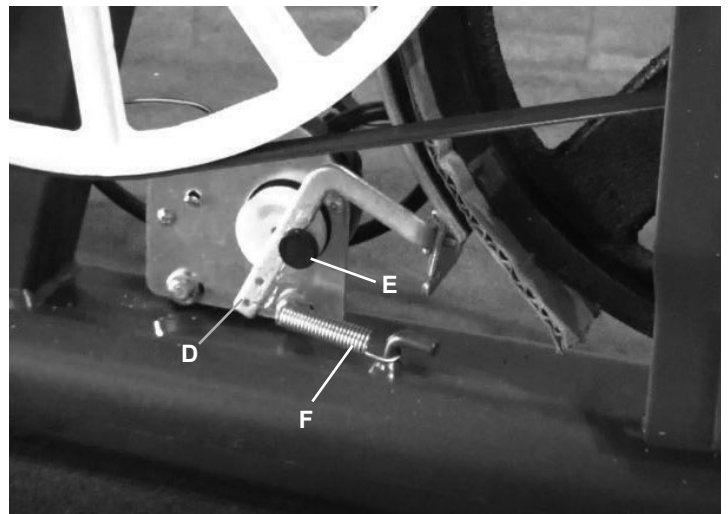

9. Loosen and remove the hex head bolt (J), nut (G) and washer (H) that attach the Brake Assembly (C) to the Main Frame bracket (K).

NOTICE: Hold the Brake Assembly so that it does not fall.
Do not pinch or cut the cables.

10. Remove the Brake Assembly (C). Remove the cardboard. Discard the old Brake Assembly.

11. Installation of the new Brake Assembly is the reverse procedure. Tape the cardboard to the new Brake Magnet. Be sure the cardboard will completely cover the new Brake Magnet before installation.

12. Turn the power on again.

 **Machine is on. Current is active. There is risk of electrical shock.**

13. Use the console to set the resistance to the highest level. This moves the Brake Magnet Arm (D) forward. After the Brake Magnet Arm stops at the highest resistance level, turn power off.

 **Disconnect all power and allow to sit for 5 minutes.**

14. If correctly calibrated, the Brake Magnet should be within 3.0 mm (1/8") of the Flywheel. If not, it will need to be adjusted. To adjust the Brake, loosen the 2 hex head bolts (M) and move the Servo Motor assembly (L) until the closest point on the Brake Magnet (C) is within 3.0 mm (1/8") of the Flywheel (B). Tighten the bolts.

Note: If the cardboard is not 3mm (1/8") thick, you can use the pages of a paperback book to measure the gap. Approximately 36 pages (sheets) = 3mm.

15. Turn the power on again. Use the console to check the resistance adjustment.

 **Machine is on. Current is active. There is risk of electrical shock.**

Note: Before fully attaching the Shrouds, remove the cardboard from between the Brake Magnet (C) and the Flywheel (B). Power up the machine to verify that the Magnet Arm can move freely, and that the Brake Magnet and Flywheel do not touch.

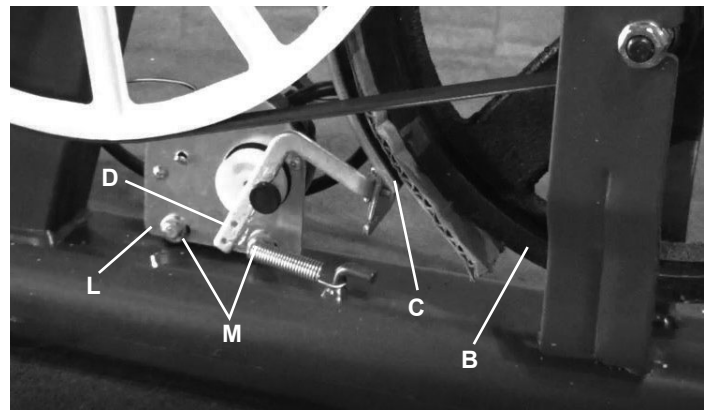

16. Installation is the reverse procedure. Put the Left Shroud in position first to align the screws for the Right Shroud. Install the top screws first.

Note: Self-tapping screws attach the Shrouds to the Frame.

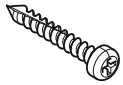

NOTICE: Be sure not to pinch or cut any cables. Be sure the tabs in the Top Shroud snap into the Main Assembly.

17. Attach the Pedals. Start the Pedals by hand, and then fully tighten them with the Pedal Wrench. The Pedals must be fully tightened.

! If the threads strip due to improper installation, then the Pedals can disengage from the bike and/or break while under usage, which can result in serious injury to the user.

Note: The Left Pedal is reverse-threaded. Be sure to attach Pedals on the correct side of the Bike. Orientation is based from a seated position on the bike. The Left Pedal has an "L", the Right Pedal an "R".

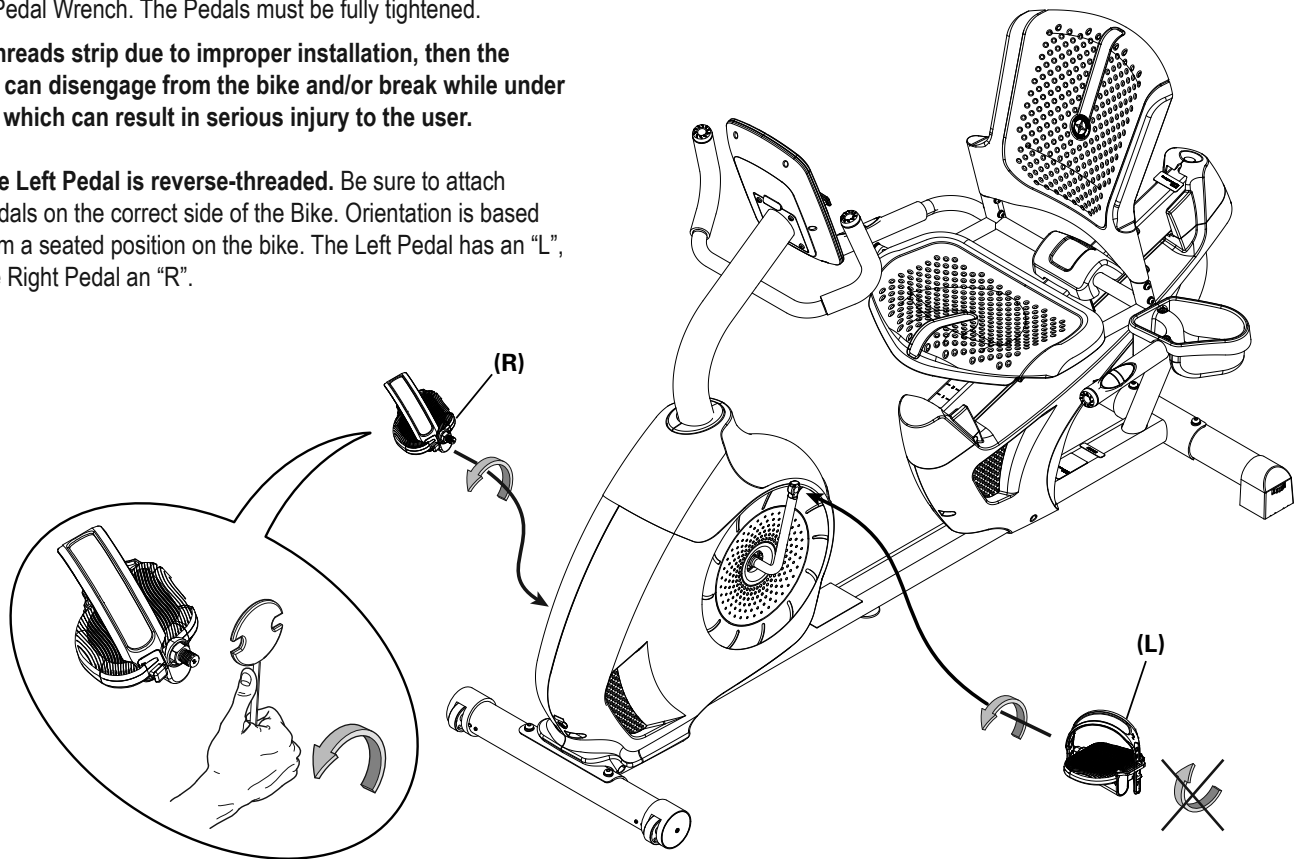

18. Final Inspection

Inspect your machine to ensure that all hardware is tight and components are properly assembled.

! Do not use until the machine has been fully assembled and inspected for correct performance in accordance with the Owner's Manual.

NOTICE: This document provides instructions for the replacement of the Console on the Schwinn™ 130 / 510U and 230 / 510R Bikes.

If you need assistance, please contact Customer Service (if purchased in US/Canada) or your local distributor (if purchased outside US/Canada). To find your local distributor, go to: www.nautilusinternational.com

 **This icon means a potentially hazardous situation which, if not avoided, could result in death or serious injury. Read and understand all Warnings on this machine.**

Nautilus, Inc., www.NautilusInc.com, 5415 Centerpoint Parkway, Groveport, OH 43125 U.S.A. - Customer Service: North America (800) 605-3369, csnls@nautilus.com | outside U.S. www.nautilusinternational.com | Printed in China | © 2022 Nautilus, Inc. | Schwinn and the Schwinn logo are trademarks owned or licensed by Nautilus, Inc., registered or otherwise protected by common law in the United States and other nations. | **ORIGINAL DOCUMENT - ENGLISH VERSION ONLY**

Important Safety Instructions - Before servicing or using this equipment, obey the following warnings:

 **This icon means a potentially hazardous situation which, if not avoided, could result in death or serious injury. Read and understand all Warnings on this machine.**

Disconnect all power to the machine before you service it.

- Read and understand the Part Replacement Procedure before working on the machine. Failure to obey the instructions and safety warnings could cause injury to the service technician or bystanders.
- Keep bystanders and children away from the product being serviced at all times.
- Make sure that the repair is done in an appropriate work space away from foot traffic and exposure to bystanders.
- Some components of the equipment can be heavy or awkward. Enlist the service of a second person when you do maintenance steps involving these components. Do not try to do heavy or awkward steps on your own.
- If replacement parts are necessary, use only genuine Nautilus replacement parts and hardware. Failure to use genuine replacement parts can cause a risk to users, keep the machine from operating correctly and void the warranty.
- Be sure that all warning stickers and instructional placards applied to the product stay present and in good condition when doing maintenance or replacing components. If at any time the Warning labels become loose, unreadable or dislodged, replace the labels. If purchased in US/Canada, contact Customer Service for replacement labels. If purchased outside US/Canada, contact your local distributor for them.
- Do not try to change the design or functionality of the machine being serviced as this can adversely affect user safety.
- Do not use the machine until all shrouds, instructions, warning labels and correct functionality have been verified and tested for correct performance.

• SAVE THESE INSTRUCTIONS.

Tools Required (not included)

#2 Phillips screwdriver



! Disconnect all power to the machine before you service it.

Note: Your machine may not match the image. For reference only.

1. Remove the four screws that attach the Console to the Mast. Carefully lift the Console off the Mast.

2. Disconnect the Data Cable and Heart Rate Cable from the back of the Console, and remove it.

Note: Do not pinch or cut the cables. Do not let the cables fall down inside the Mast. This step may require two people.

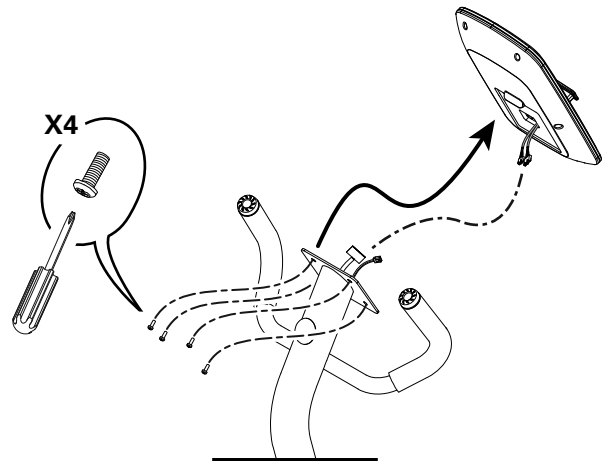

3. Installation is the reverse procedure.

Note: Do not pinch or cut the cables. Align the clips on the cable connectors and make sure the connectors lock.

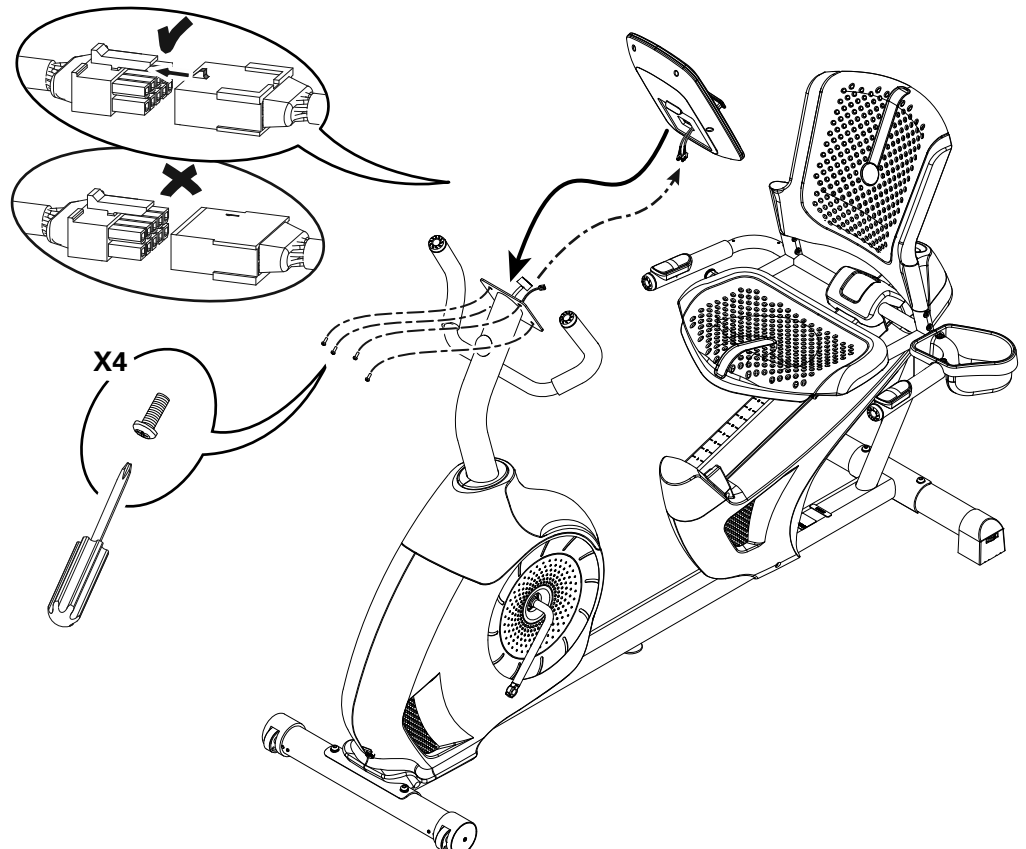

4. Final Inspection

Inspect your machine to ensure that all hardware is tight and components are properly assembled.

! Do not use until the machine has been fully assembled and inspected for correct performance in accordance with the Owner's Manual.

NOTICE: This document provides instructions for the replacement of the Console Mast (Upright Handlebar Assembly) on the Schwinn™ 230 / 510R Recumbent Bikes.

If you need assistance, please contact Customer Service (if purchased in US/Canada) or your local distributor (if purchased outside US/Canada). To find your local distributor, go to: www.nautilusinternational.com

 **This icon means a potentially hazardous situation which, if not avoided, could result in death or serious injury. Read and understand all Warnings on this machine.**

Nautilus, Inc., www.NautilusInc.com, 5415 Centerpoint Parkway, Groveport, OH 43125 U.S.A. - Customer Service: North America (800) 605-3369, csnls@nautilus.com | outside U.S. www.nautilusinternational.com | Printed in China | © 2022 Nautilus, Inc. | Schwinn and the Schwinn logo are trademarks owned or licensed by Nautilus, Inc., registered or otherwise protected by common law in the United States and other nations. | **ORIGINAL DOCUMENT - ENGLISH VERSION ONLY**

Important Safety Instructions - Before servicing or using this equipment, obey the following warnings:

 **This icon means a potentially hazardous situation which, if not avoided, could result in death or serious injury. Read and understand all Warnings on this machine.**

Disconnect all power to the machine before you service it.

- Read and understand the Part Replacement Procedure before working on the machine. Failure to obey the instructions and safety warnings could cause injury to the service technician or bystanders.
- Keep bystanders and children away from the product being serviced at all times.
- Make sure that the repair is done in an appropriate work space away from foot traffic and exposure to bystanders.
- Some components of the equipment can be heavy or awkward. Enlist the service of a second person when you do maintenance steps involving these components. Do not try to do heavy or awkward steps on your own.
- If replacement parts are necessary, use only genuine Nautilus replacement parts and hardware. Failure to use genuine replacement parts can cause a risk to users, keep the machine from operating correctly and void the warranty.
- Be sure that all warning stickers and instructional placards applied to the product stay present and in good condition when doing maintenance or replacing components. If at any time the Warning labels become loose, unreadable or dislodged, replace the labels. If purchased in US/Canada, contact Customer Service for replacement labels. If purchased outside US/Canada, contact your local distributor for them.
- Do not try to change the design or functionality of the machine being serviced as this can adversely affect user safety.
- Do not use the machine until all shrouds, instructions, warning labels and correct functionality have been verified and tested for correct performance.

• SAVE THESE INSTRUCTIONS.

Tools Required (not included)

#2 Phillips screwdriver



Small flathead screwdriver



6mm hex wrench



! Disconnect all power to the machine before you service it.

Note: Your machine may not match the image. For reference only.

1. Remove the four screws that attach the Console to the Mast. Carefully lift the Console off the Mast.

2. Disconnect the Data Cable and Heart Rate Cable from the back of the Console, and remove it.

Note: Do not let the cables fall down inside the Mast. This step may require two people.

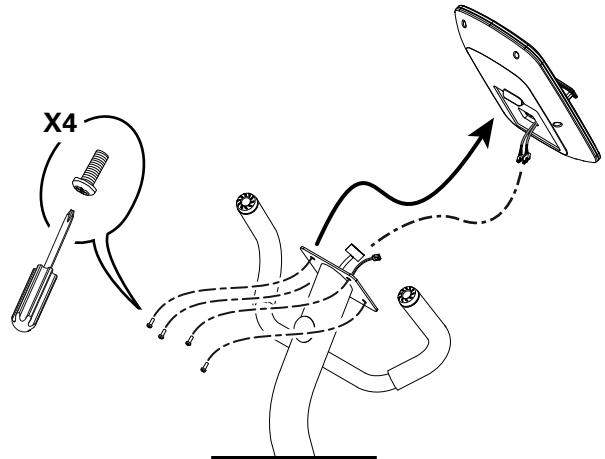

3. Gently remove the Shroud Cap from the Upper Shroud, and remove it from the Console Mast.

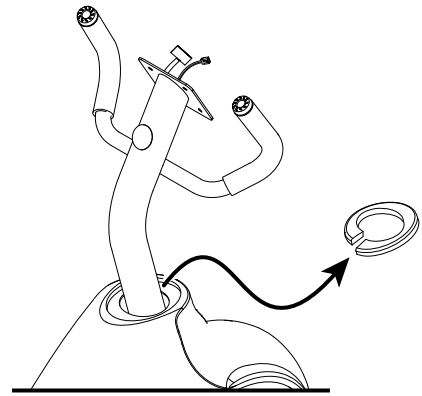

4. Flex the edges of the Upper Shroud to disengage the inside tabs from the Main Assembly, and slide it up the Console Mast.

5. Using a 6mm hex wrench, remove the indicated hardware from the Console Mast. Slightly pull the Console Mast upward, and disconnect the cables. Set the hardware and Upper Shroud safely aside for reassembly. Discard the old Console Mast.

NOTICE: Do not pinch or cut the cables.
This step may require two people.

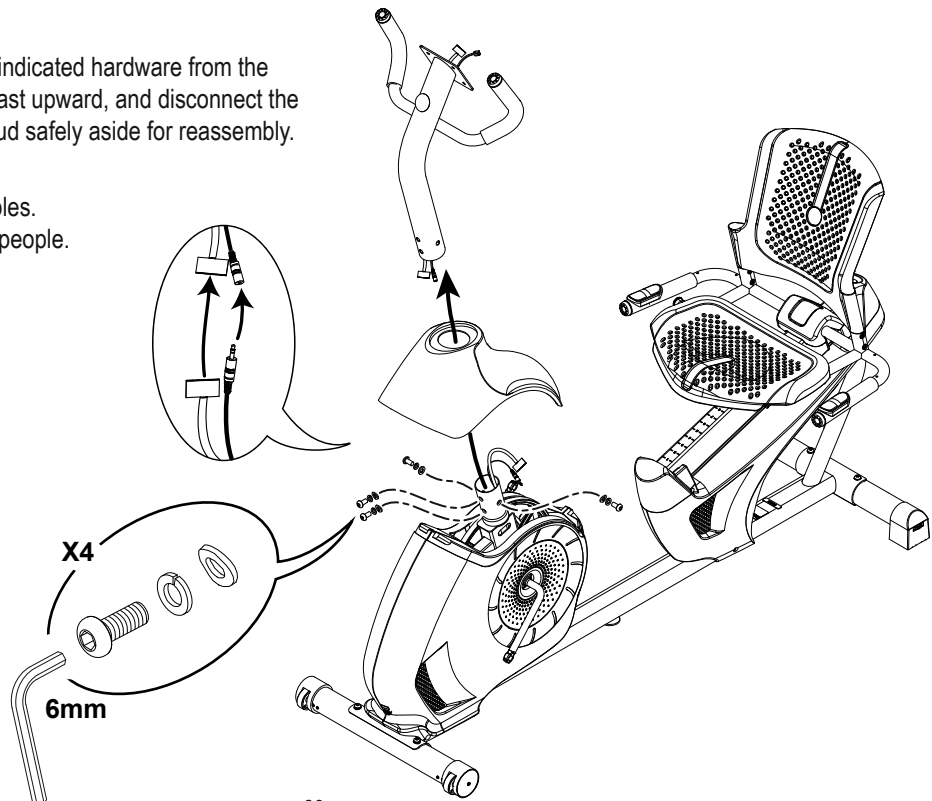

6. Installation is the reverse procedure.

Note: Do not pinch or cut the cables. Align the clips on the cable connectors and make sure the connectors lock.

7. Discard the old parts.

8. Final Inspection

Inspect your machine to ensure that all hardware is tight and components are properly assembled.



Do not use until the machine has been fully assembled and inspected for correct performance in accordance with the Owner's Manual.

NOTICE: This document provides instructions for the replacement of the Data Cable in the Console Mast on the Schwinn™ 130 / 510U Upright Bikes and 230 / 510R Recumbent Bikes.

If you need assistance, please contact Customer Service (if purchased in US/Canada) or your local distributor (if purchased outside US/Canada). To find your local distributor, go to: www.nautilusinternational.com

! This icon means a potentially hazardous situation which, if not avoided, could result in death or serious injury. Read and understand all Warnings on this machine.

Nautilus, Inc., www.NautilusInc.com, 5415 Centerpoint Parkway, Groveport, OH 43125 U.S.A. - Customer Service: North America (800) 605-3369, csnls@nautilus.com | outside U.S. www.nautilusinternational.com | Printed in China | © 2022 Nautilus, Inc. | Schwinn and the Schwinn logo are trademarks owned or licensed by Nautilus, Inc., registered or otherwise protected by common law in the United States and other nations. | **ORIGINAL DOCUMENT - ENGLISH VERSION ONLY**

Important Safety Instructions - Before servicing or using this equipment, obey the following warnings:

! This icon means a potentially hazardous situation which, if not avoided, could result in death or serious injury. Read and understand all Warnings on this machine.

Disconnect all power to the machine before you service it.

- Read and understand the Part Replacement Procedure before working on the machine. Failure to obey the instructions and safety warnings could cause injury to the service technician or bystanders.
- Keep bystanders and children away from the product being serviced at all times.
- Make sure that the repair is done in an appropriate work space away from foot traffic and exposure to bystanders.
- Some components of the equipment can be heavy or awkward. Enlist the service of a second person when you do maintenance steps involving these components. Do not try to do heavy or awkward steps on your own.
- If replacement parts are necessary, use only genuine Nautilus replacement parts and hardware. Failure to use genuine replacement parts can cause a risk to users, keep the machine from operating correctly and void the warranty.
- Be sure that all warning stickers and instructional placards applied to the product stay present and in good condition when doing maintenance or replacing components. If at any time the Warning labels become loose, unreadable or dislodged, replace the labels. If purchased in US/Canada, contact Customer Service for replacement labels. If purchased outside US/Canada, contact your local distributor for them.
- Do not try to change the design or functionality of the machine being serviced as this can adversely affect user safety.
- Do not use the machine until all shrouds, instructions, warning labels and correct functionality have been verified and tested for correct performance.

• SAVE THESE INSTRUCTIONS.

Tools Required (not included)

#2 Phillips screwdriver

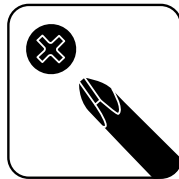

5' (152 cm) length of string

Small flathead screwdriver



6mm hex wrench



! Disconnect all power to the machine before you service it.

Note: Your machine may not match the image. For reference only.

1. Remove the four screws that attach the Console to the Mast. Carefully lift the Console off the Mast.

2. Disconnect the Data Cable and Heart Rate Cable from the back of the Console, and remove it.

Note: Do not let the cables fall down inside the Mast. This step may require two people.

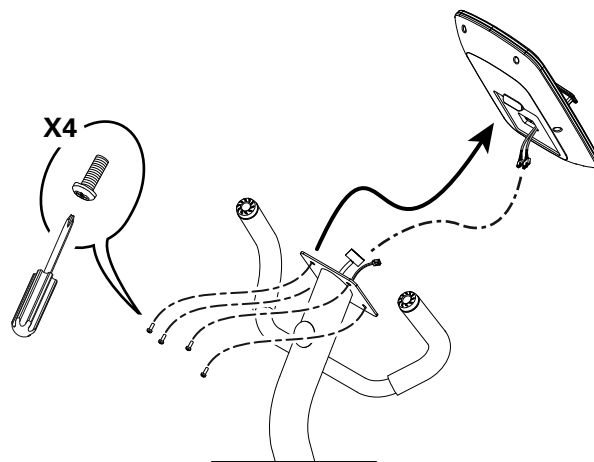

3. Gently remove the Shroud Cap from the Upper Shroud, and remove it from the Console Mast.

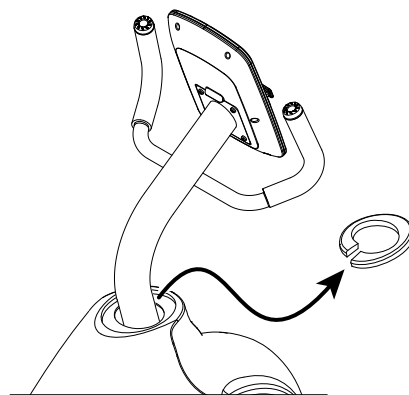

4. Flex the edges of the Upper Shroud to disengage the inside tabs from the Main Assembly, and slide it up the Console Mast.

5. Using a 6mm hex wrench, remove the indicated hardware from the Console Mast. Slightly pull the Console Mast upward, and disconnect the cables. Set the hardware and Upper Shroud safely aside for reassembly. Discard the old Console Mast.

NOTICE: Do not pinch or cut the cables.
This step may require two people.

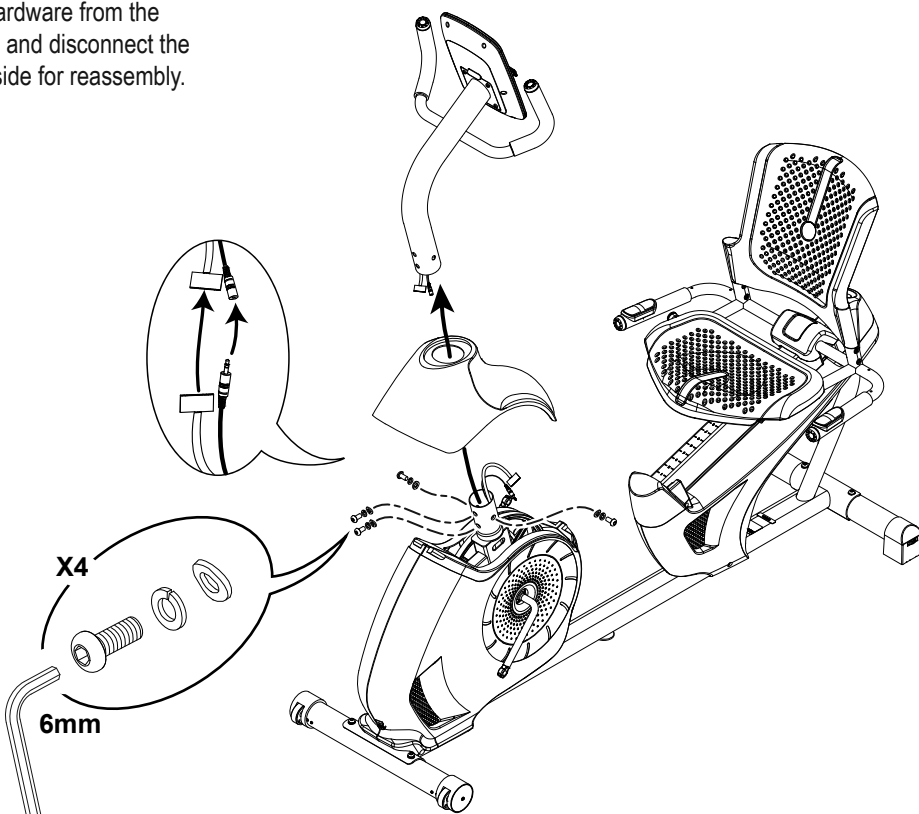

6. Tie a length of string to the end of the old Data Cable at the base of the Console Mast. Hold the other end of the old Data Cable and carefully pull it out of the Console Mast so that the string extends through the length of the Console Mast. Untie the string and discard the old Data Cable.

NOTICE: Hold the Heart Rate (HR) Cable so that you do not pull it out of the Mast. Do not pinch or cut the HR cable.

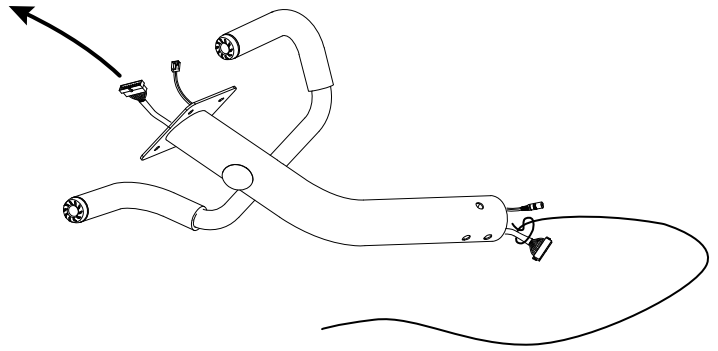

7. Tie the end of the string at the base of the Console Mast to appropriate end of the replacement Data Cable. Hold the other end of the string and carefully pull the new Data Cable through the Console Mast.

NOTICE: Hold the HR Cable so that you do not pull it out of the Mast. Do not pinch or cut the cables.

8. Untie the string from the new Data Cable, and connect the cable to the Data Cable from the Main Frame.

NOTICE: Do not pinch or cut the cables. This step may require two people.

9. Put the Console Mast (with the Upper Shroud) back in position in the Main Frame, and reinstall the Hardware.

Note: Do not let the cables fall down inside the Console Mast.

NOTICE: Be sure not to pinch or cut any cables. This step may require two people.

10. Slide the Upper Shroud back into position and reinstall the Shroud Cap.

NOTICE: Be sure the tabs in the Upper Shroud snap into the Main Assembly.

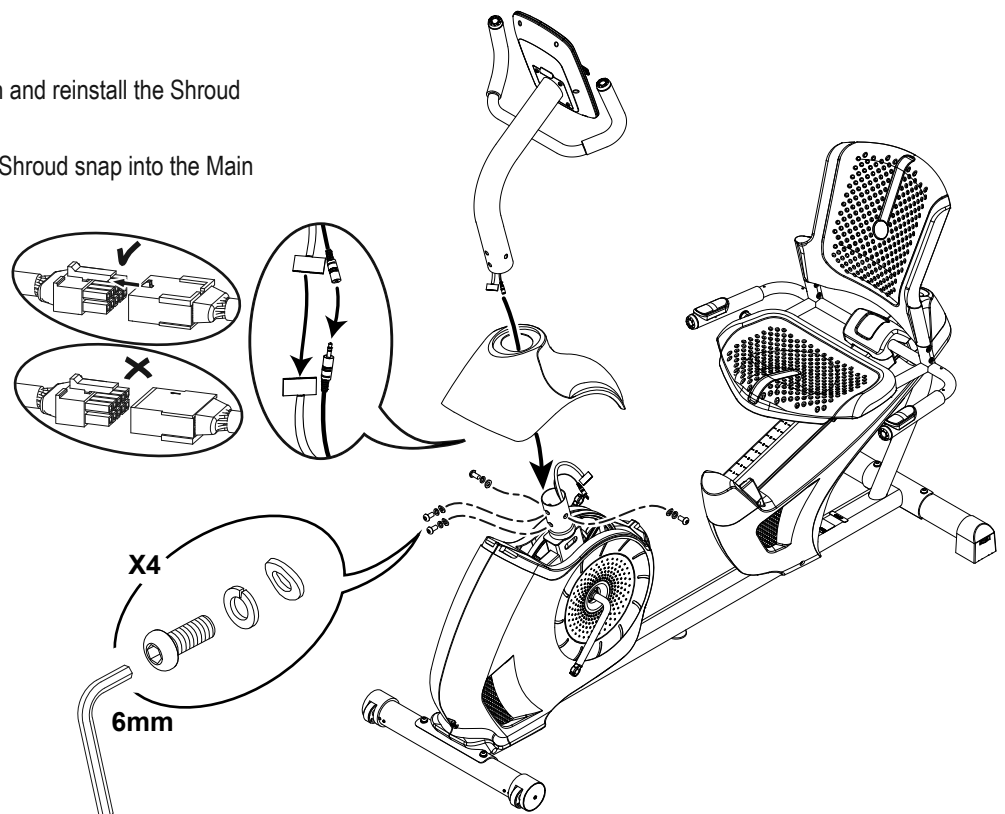

11. Connect the cables to the back of the Console, and then attach the Console to the Console Mast using a #2 screwdriver.

NOTICE: Do not pinch or cut the cables. Align the clips on the cable connectors and make sure the connectors lock.

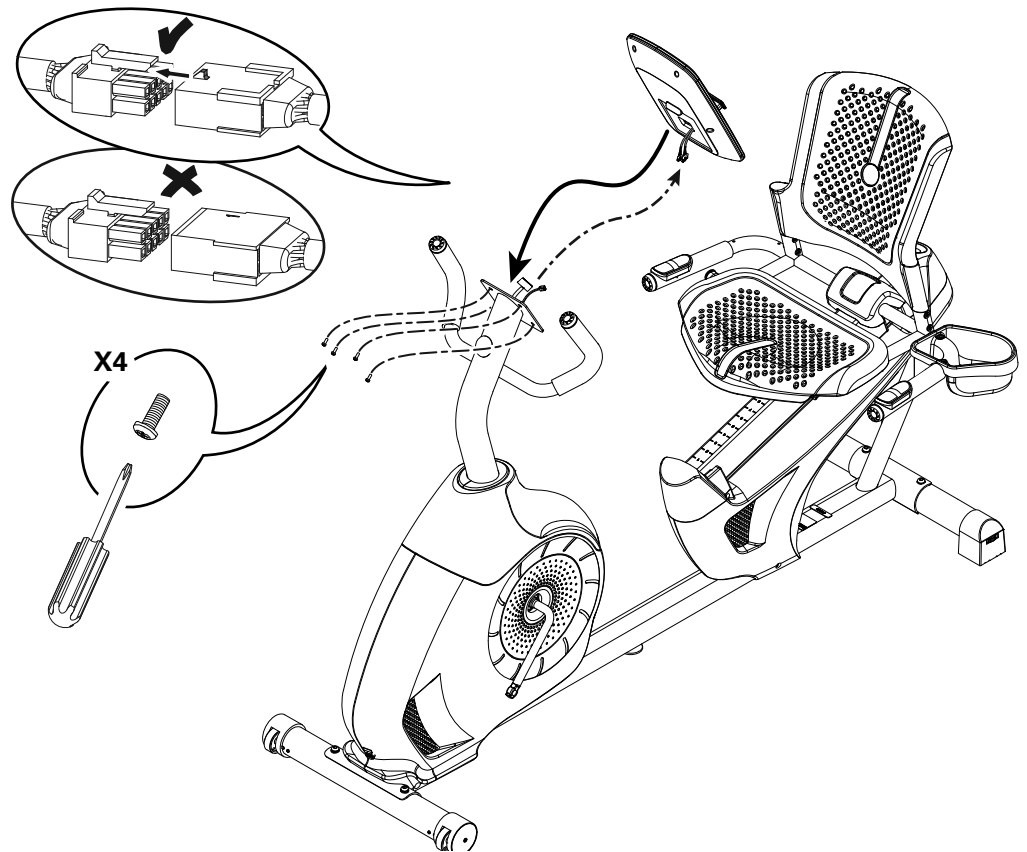

12. Final Inspection

Inspect your machine to ensure that all hardware is tight and components are properly assembled.



Do not use until the machine has been fully assembled and inspected for correct performance in accordance with the Owner's Manual.

NOTICE: This document provides instructions for the replacement of the Drive Belt on the Schwinn™ 130 / 510U Upright Bikes and 230 / 510R Recumbent Bikes.

If you need assistance, please contact Customer Service (if purchased in US/Canada) or your local distributor (if purchased outside US/Canada). To find your local distributor, go to: www.nautilusinternational.com

 **This icon means a potentially hazardous situation which, if not avoided, could result in death or serious injury. Read and understand all Warnings on this machine.**

Nautilus, Inc., www.NautilusInc.com, 5415 Centerpoint Parkway, Groveport, OH 43125 U.S.A. - Customer Service: North America (800) 605-3369, csnls@nautilus.com | outside U.S. www.nautilusinternational.com | Printed in China | © 2022 Nautilus, Inc. | Schwinn and the Schwinn logo are trademarks owned or licensed by Nautilus, Inc., registered or otherwise protected by common law in the United States and other nations. | **ORIGINAL DOCUMENT - ENGLISH VERSION ONLY**

Important Safety Instructions - Before servicing or using this equipment, obey the following warnings:

 **This icon means a potentially hazardous situation which, if not avoided, could result in death or serious injury. Read and understand all Warnings on this machine.**

Disconnect all power to the machine before you service it.

- Read and understand the Part Replacement Procedure before working on the machine. Failure to obey the instructions and safety warnings could cause injury to the service technician or bystanders.
- Keep bystanders and children away from the product being serviced at all times.
- Make sure that the repair is done in an appropriate work space away from foot traffic and exposure to bystanders.
- Some components of the equipment can be heavy or awkward. Enlist the service of a second person when you do maintenance steps involving these components. Do not try to do heavy or awkward steps on your own.
- If replacement parts are necessary, use only genuine Nautilus replacement parts and hardware. Failure to use genuine replacement parts can cause a risk to users, keep the machine from operating correctly and void the warranty.
- Be sure that all warning stickers and instructional placards applied to the product stay present and in good condition when doing maintenance or replacing components. If at any time the Warning labels become loose, unreadable or dislodged, replace the labels. If purchased in US/Canada, contact Customer Service for replacement labels. If purchased outside US/Canada, contact your local distributor for them.
- Do not try to change the design or functionality of the machine being serviced as this can adversely affect user safety.
- Do not use the machine until all shrouds, instructions, warning labels and correct functionality have been verified and tested for correct performance.

• SAVE THESE INSTRUCTIONS.

Tools Required (not included)

#2 Phillips screwdriver



15mm open end wrench

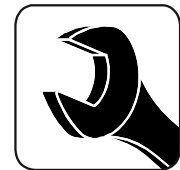

Small flathead screwdriver



15mm socket and wrench



Pedal wrench or 15mm open end wrench



Safety goggles or other eye protection

Needlenose pliers



2.5" x 10" cardboard and tape



! Disconnect all power to the machine before you service it.

Note: Your machine may not match the image. For reference only.

1. Loosen and remove the Pedals.

Note: The Left Pedal is reverse-threaded. Orientation is based from a seated position on the bike. The Left Pedal has an "L", the Right Pedal an "R".

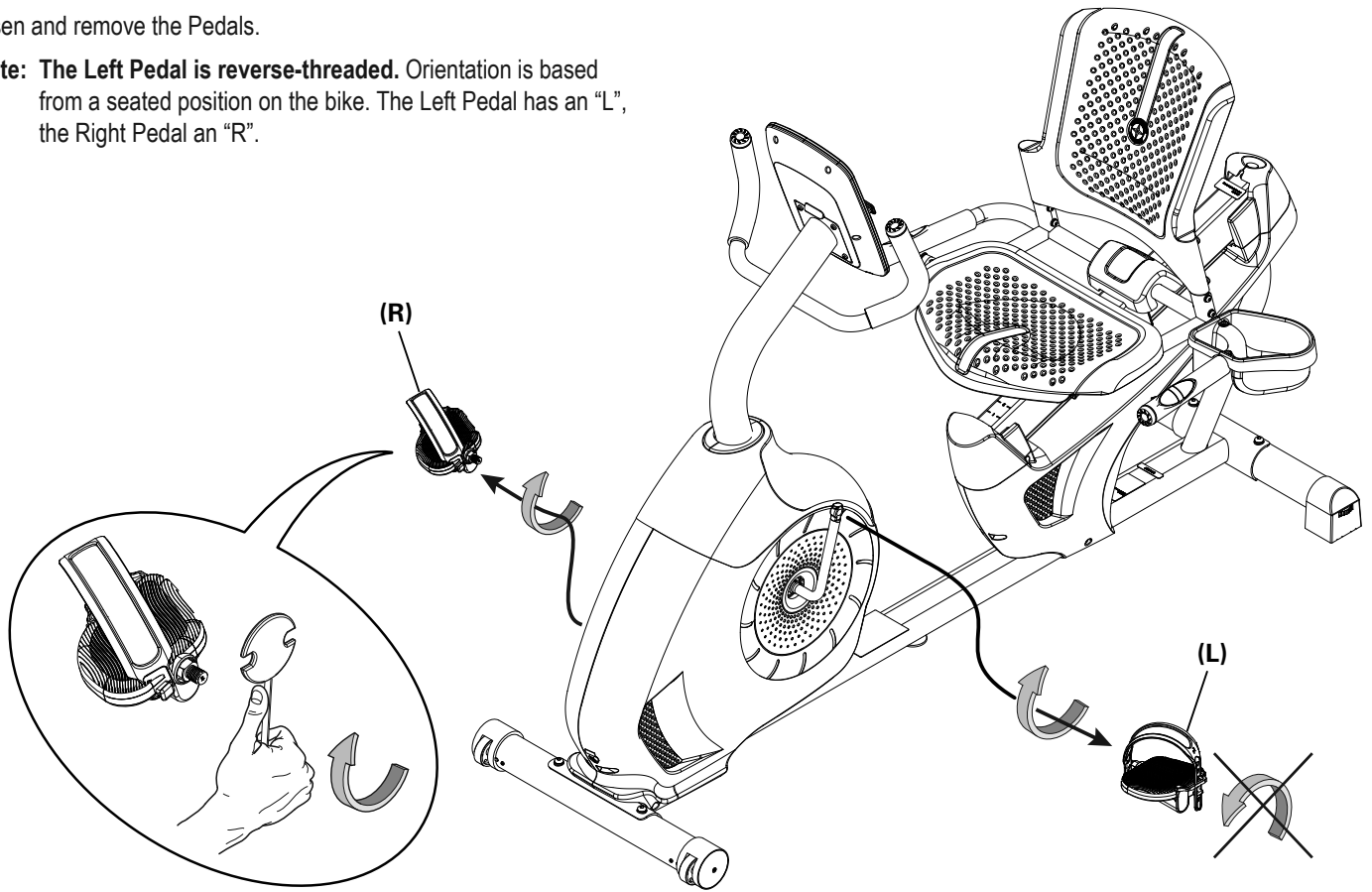

2. Gently remove the Shroud Cap from the Upper Shroud, and remove it from the Console Mast.

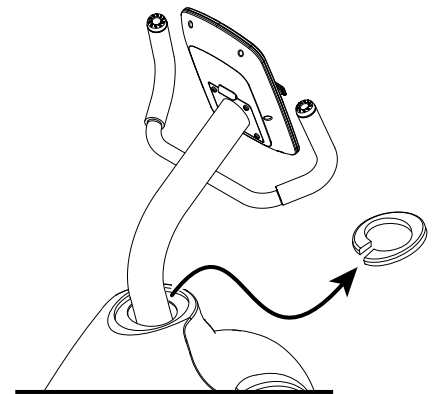

3. Flex the edges of the Upper Shroud to disengage the inside tabs from the Main Assembly, and slide it up the Console Mast.

4. Using a 6mm hex wrench, remove the indicated hardware from the Console Mast. Slightly pull the Console Mast upward, and disconnect the cables. Set the hardware, Shroud Cap, and Upper Shroud safely aside for reassembly. Discard the old Console Mast.

NOTICE: Do not pinch or cut the cables.
This step may require two people.

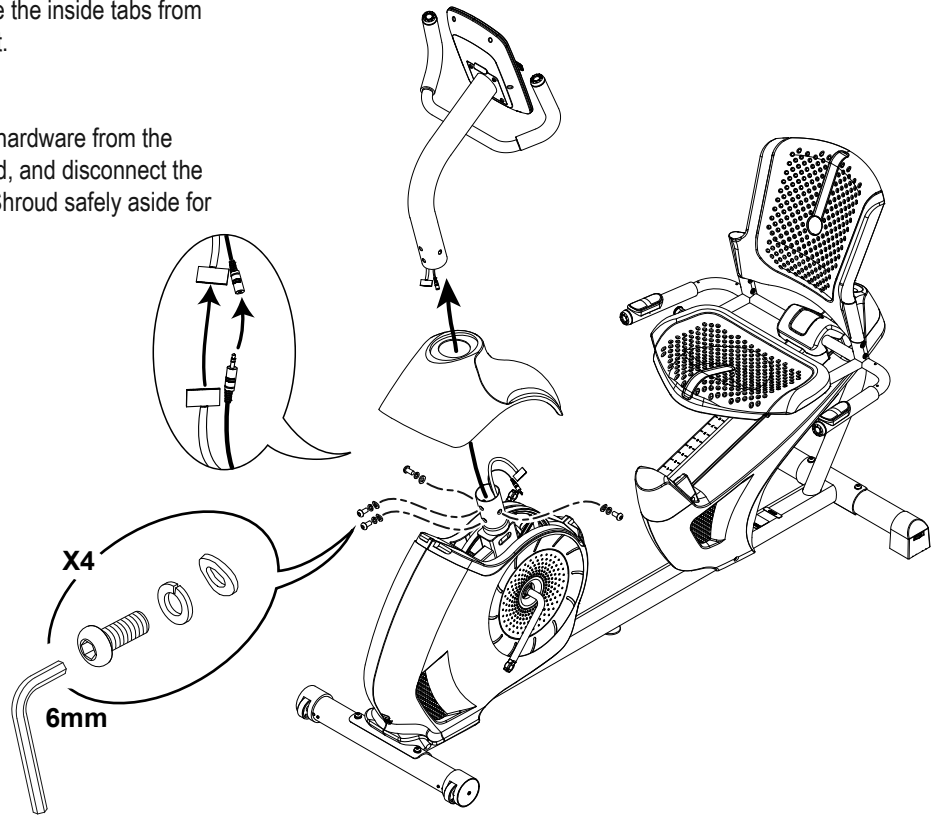

5. Using a #2 Phillips Screwdriver, remove the 6 screws (indicated) that secure the Left Main Shroud. Remove the bottom screws first, and then the top screws. Set the hardware safely aside for reassembly. Slowly remove the Left Main Shroud.

Note: The Power Inlet Cable (A1) is attached to the inside of the Left Main Shroud. Be sure not to pinch or cut the cable by placing the Left Main Shroud close to the side of the machine.

NOTICE: Do not pinch or cut the cables.

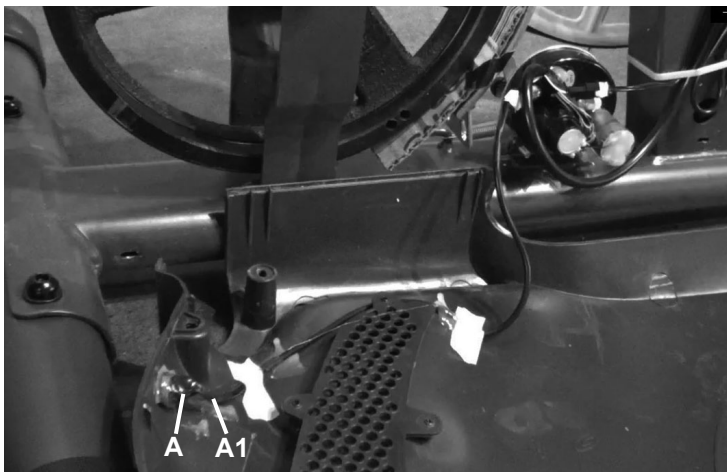
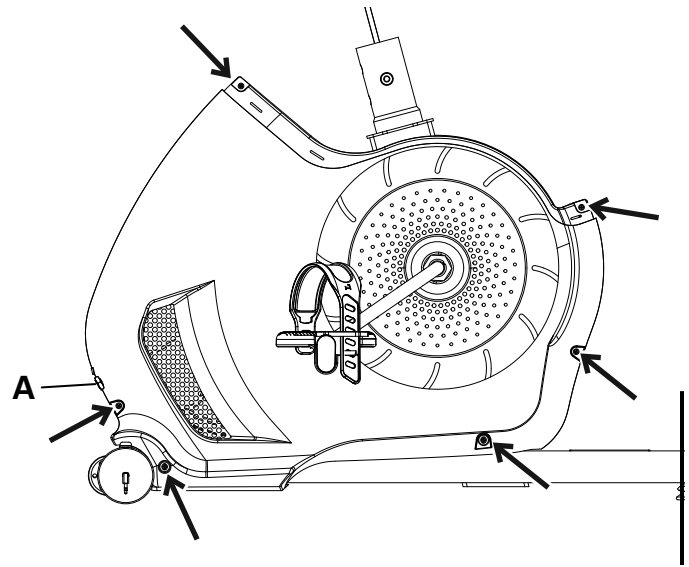

6. Using a #2 Phillips Screwdriver, remove the 2 screws that secure the Right Main Shroud. Slowly remove the Right Main Shroud. Set the hardware and Shroud safely aside for reassembly.

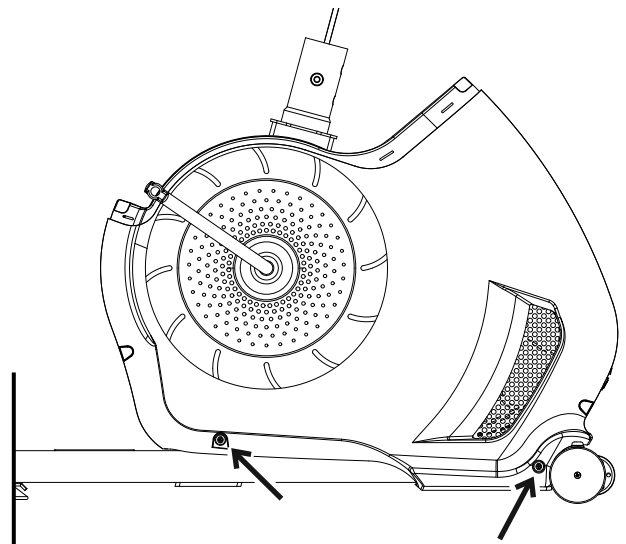

7. Insert 2.5" x 10" cardboard between the Brake Magnet (C) and the Flywheel (B), and tape the cardboard to the Brake Magnet.

Note: Be sure the cardboard covers all of the Brake Magnet.

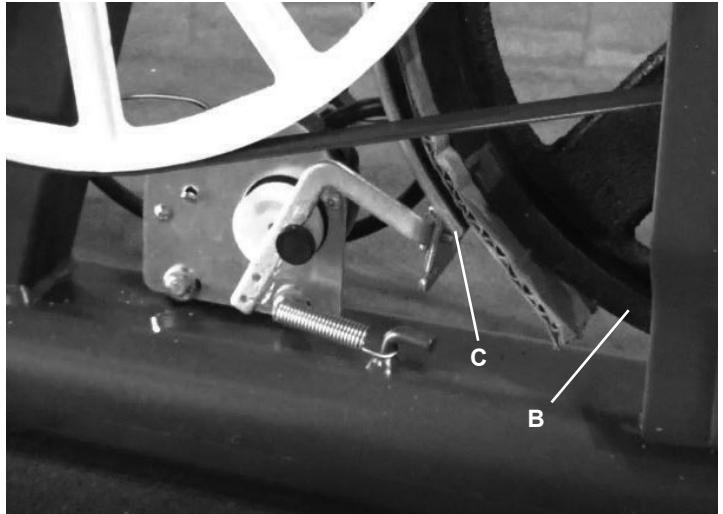

8. Slowly turn the Drive Pulley (D) backward and carefully ease the Drive Belt (E) off the Drive Pulley to the outside.

 **Be sure to keep fingers clear of all pinch hazards as you turn the Drive Pulley.**

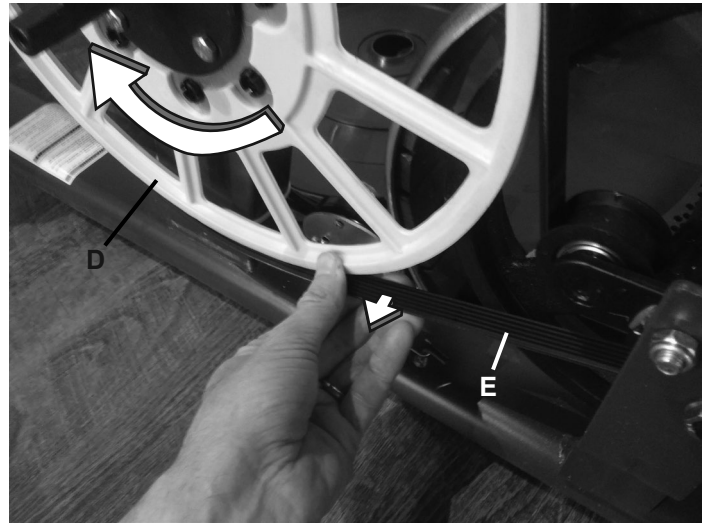

9. Using needlenose pliers, carefully release the spring (F) on the Belt Tensioner (G).



10. To remove the hardware from the Flywheel (H), use the 15mm open end wrench to hold the nut (J) on one side steady and remove the nut on the opposite side with the 15mm socket and wrench. Set the hardware safely aside.

11. Remove the Flywheel (H) from the Main Frame brackets (K) and the Drive Belt (E).

Note: The Flywheel is heavy.

12. Remove the old Drive Belt (E) and discard it.

13. Hold the Flywheel (H) near the Main Frame brackets (K) and put the new Drive Belt (E) in position on the Flywheel pulley (H1). Put the Drive Belt in position around the Belt Tensioner (G). Be sure that the upper portion of the Drive Belt is under the bearings on the Belt Tensioner.

NOTICE: This step may require two people.

14. Align the Flywheel axle in the Main Frame brackets (K). Hand tighten the hardware on each end of the Flywheel axle.

15. Put the Drive Belt (E) onto the Drive Pulley (D). Make sure the Drive Belt is aligned on the Flywheel pulley (H1), Belt Tensioner (G) and Drive Pulley.

16. Before you fully tighten the Flywheel hardware, reattach the Belt Tensioner spring (F) with the pliers.

17. Remove the cardboard from the Brake Assembly.

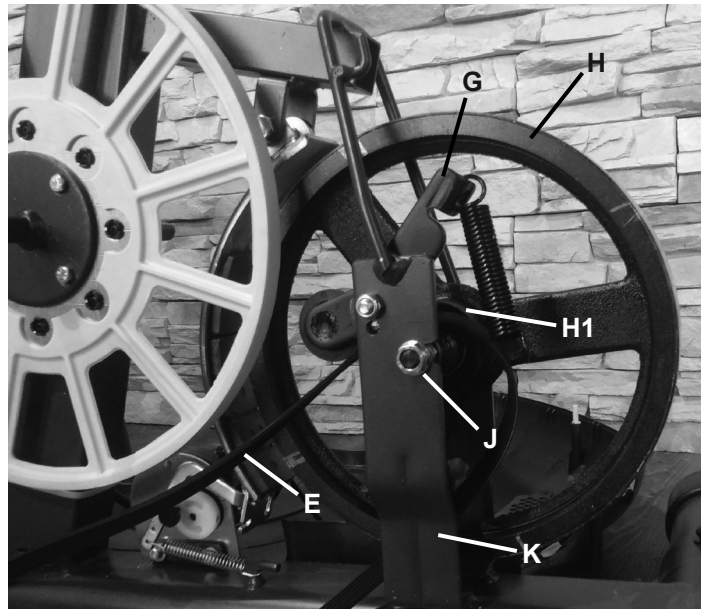

18. Test the Drive Belt tension to be sure that it is correct.

- Push the Drive Belt downward at the midpoint (M) between the pulleys and measure the distance. The Drive Belt should have only 0.25" (0.64cm) of give. See Figure 1.

Or:

- Hold the edges of the Drive Belt at the midpoint (M) and twist it (see Figure 2). It should turn only 90 degrees (1/4 turn, to vertical).

If the tension is correct, go to Step 22.

If the tension is too loose or too tight, adjust the position of the Flywheel. Continue to the next step.

19. To loosen the Flywheel hardware (J), use a 15mm open end wrench to hold the nut on one side steady and loosen the nut on the opposite side with a 15mm socket and wrench.

20. Move the Flywheel in the Main Frame bracket as necessary to adjust the tension. Hold it in position and tighten the hardware.

Note: This step may require two people.

To tighten the Flywheel hardware, use a 15mm open end wrench to hold the nut on one side steady and tighten the nut on the opposite side with a 15mm socket and wrench.

21. Carefully turn the crank arms and check the movement of the drive belt. The Crank Arms and Flywheel should move as one.

⚠ Be sure to keep fingers clear of all pinch hazards when you turn the Drive Pulley.

Adjust the belt tension again if necessary.

Figure 1

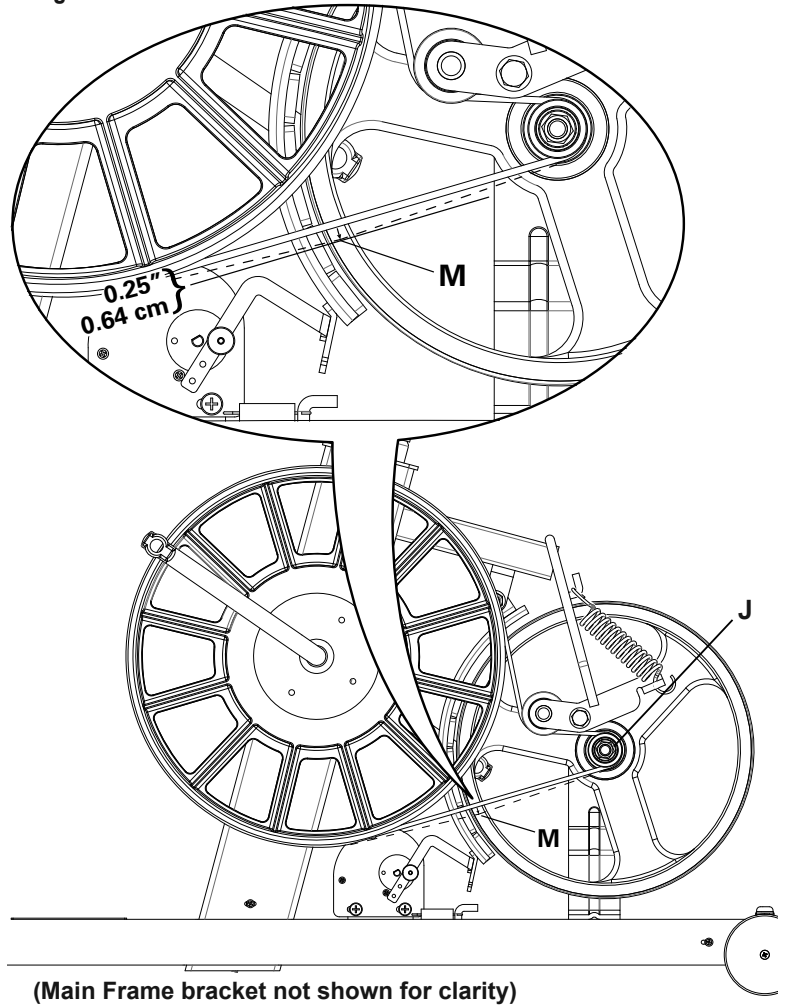

Figure 2



22. To tighten the Flywheel hardware, use the 15mm open end wrench to hold the nut (J) on one side steady and tighten the nut on the opposite side with the 15mm socket and wrench.

Note: Before fully attaching the Shrouds, power up the machine to verify that the Magnet Arm can move freely, and that the Brake Magnet and Flywheel do not touch at the maximum resistance level.

23. Turn the power on again. Use the console to check the resistance adjustment.

⚠ Machine is on. Current is active. There is risk of electrical shock.

Note: Power up the machine to verify that the Magnet Arm can move freely, and that the Brake Magnet and Flywheel do not touch.



24. Installation is the reverse procedure. Put the Left Shroud in position first to align the screws for the Right Shroud. Install the top screws first.

Note: Self-tapping screws attach the Shrouds to the Frame.

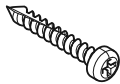

NOTICE: Be sure not to pinch or cut any cables. Be sure the tabs in the Top Shroud snap into the Main Assembly.

25. Attach the Pedals. Start the Pedals by hand, and then fully tighten them with the Pedal Wrench. The Pedals must be fully tightened.

⚠ If the threads strip due to improper installation, then the Pedals can disengage from the bike and/or break while under usage, which can result in serious injury to the user.

Note: The Left Pedal is reverse-threaded. Be sure to attach Pedals on the correct side of the Bike. Orientation is based from a seated position on the bike. The Left Pedal has an "L", the Right Pedal an "R".

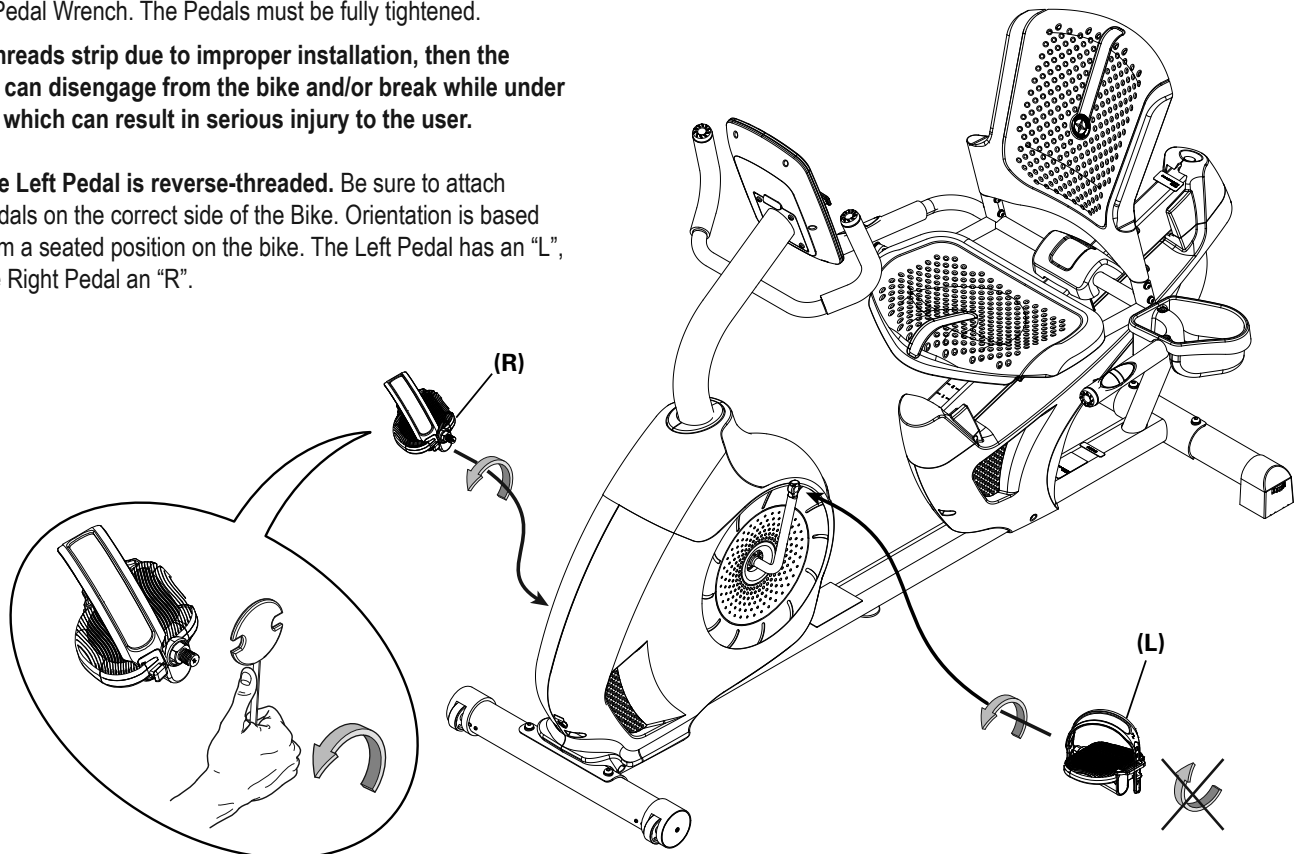

26. Final Inspection

Inspect your machine to ensure that all hardware is tight and components are properly assembled.



Do not use until the machine has been fully assembled and inspected for correct performance in accordance with the Owner's Manual.

NOTICE: This document provides instructions for the replacement of the Drive Pulley (1-piece Crank Assembly) on the Schwinn™ 130 / 510U Upright Bikes and 230 / 510R Recumbent Bikes.

If you need assistance, please contact Customer Service (if purchased in US/Canada) or your local distributor (if purchased outside US/Canada). To find your local distributor, go to: www.nautilusinternational.com

! This icon means a potentially hazardous situation which, if not avoided, could result in death or serious injury. Read and understand all Warnings on this machine.

Nautilus, Inc., www.NautilusInc.com, 5415 Centerpoint Parkway, Groveport, OH 43125 U.S.A. - Customer Service: North America (800) 605-3369, csnls@nautilus.com | outside U.S. www.nautilusinternational.com | Printed in China | © 2022 Nautilus, Inc. | Schwinn and the Schwinn logo are trademarks owned or licensed by Nautilus, Inc., registered or otherwise protected by common law in the United States and other nations. | **ORIGINAL DOCUMENT - ENGLISH VERSION ONLY**

Important Safety Instructions - Before servicing or using this equipment, obey the following warnings:

! This icon means a potentially hazardous situation which, if not avoided, could result in death or serious injury. Read and understand all Warnings on this machine.

Disconnect all power to the machine before you service it.

- Read and understand the Part Replacement Procedure before working on the machine. Failure to obey the instructions and safety warnings could cause injury to the service technician or bystanders.
- Keep bystanders and children away from the product being serviced at all times.
- Make sure that the repair is done in an appropriate work space away from foot traffic and exposure to bystanders.
- Some components of the equipment can be heavy or awkward. Enlist the service of a second person when you do maintenance steps involving these components. Do not try to do heavy or awkward steps on your own.
- If replacement parts are necessary, use only genuine Nautilus replacement parts and hardware. Failure to use genuine replacement parts can cause a risk to users, keep the machine from operating correctly and void the warranty.
- Be sure that all warning stickers and instructional placards applied to the product stay present and in good condition when doing maintenance or replacing components. If at any time the Warning labels become loose, unreadable or dislodged, replace the labels. If purchased in US/Canada, contact Customer Service for replacement labels. If purchased outside US/Canada, contact your local distributor for them.
- Do not try to change the design or functionality of the machine being serviced as this can adversely affect user safety.
- Do not use the machine until all shrouds, instructions, warning labels and correct functionality have been verified and tested for correct performance.

• SAVE THESE INSTRUCTIONS.

Tools Required (not included)

#2 Phillips screwdriver



Needlenose pliers

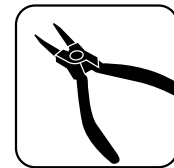

Small flathead screwdriver



32mm open end wrench
or adjustable wrench



Pedal wrench or 15mm open end
wrench



Safety goggles or other eye protection



! Disconnect all power to the machine before you service it.

Note: Your machine may not match the image. For reference only.

1. Loosen and remove the Pedals.

Note: The Left Pedal is reverse-threaded.

Orientation is based from a seated position on the bike. The Left Pedal has an "L", the Right Pedal an "R".

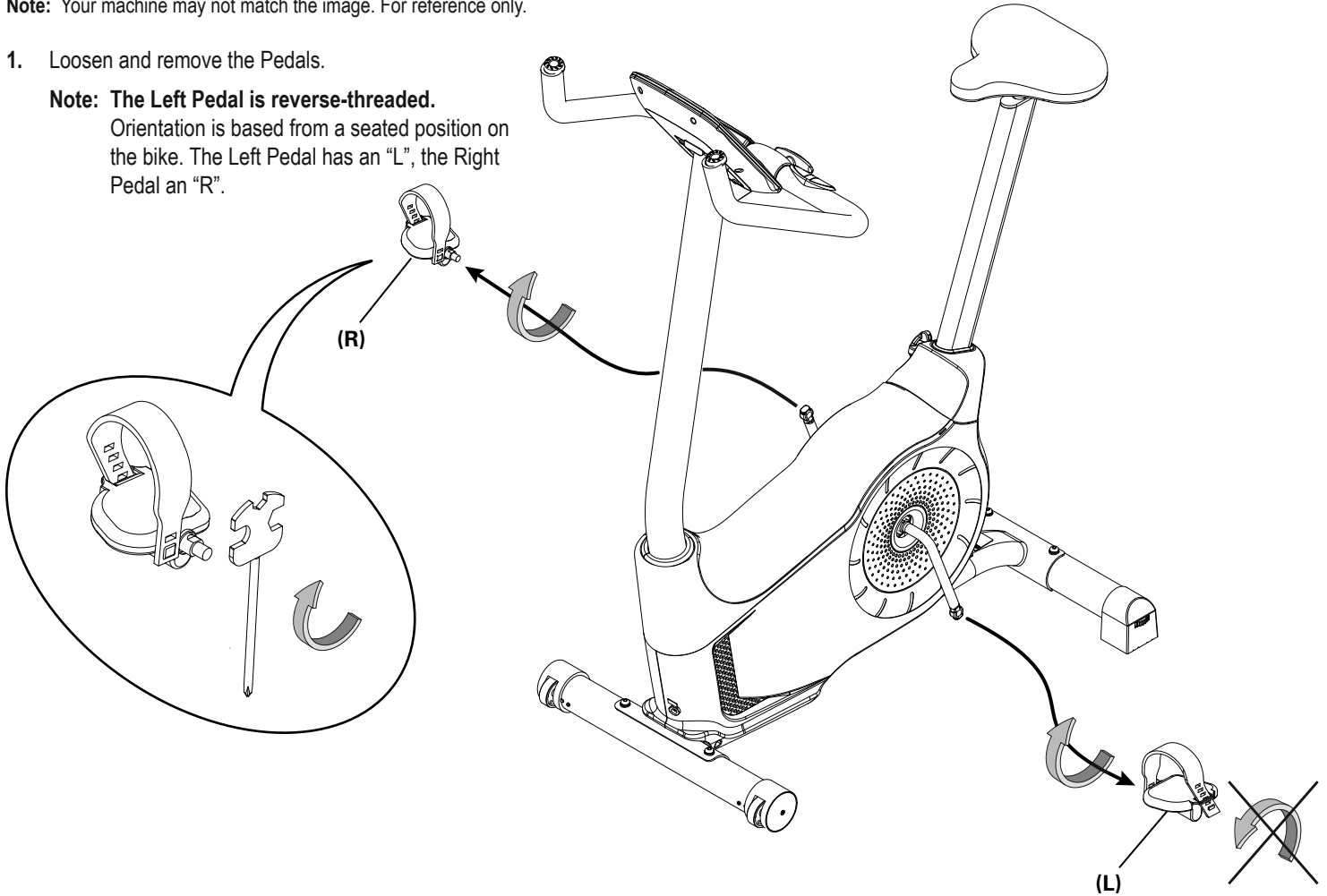

2. Remove the Seat Post Adjustment Knob and Seat Post Assembly from the Main Assembly.

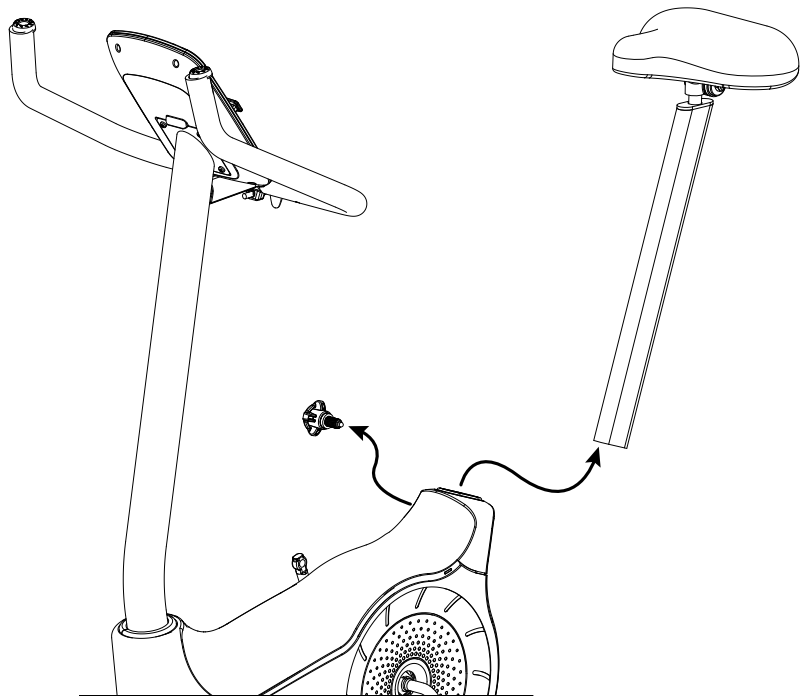

3. Flex the edges of the Upper Shroud to disengage the inside tabs from the Main Assembly, and slide it up the Console Mast.

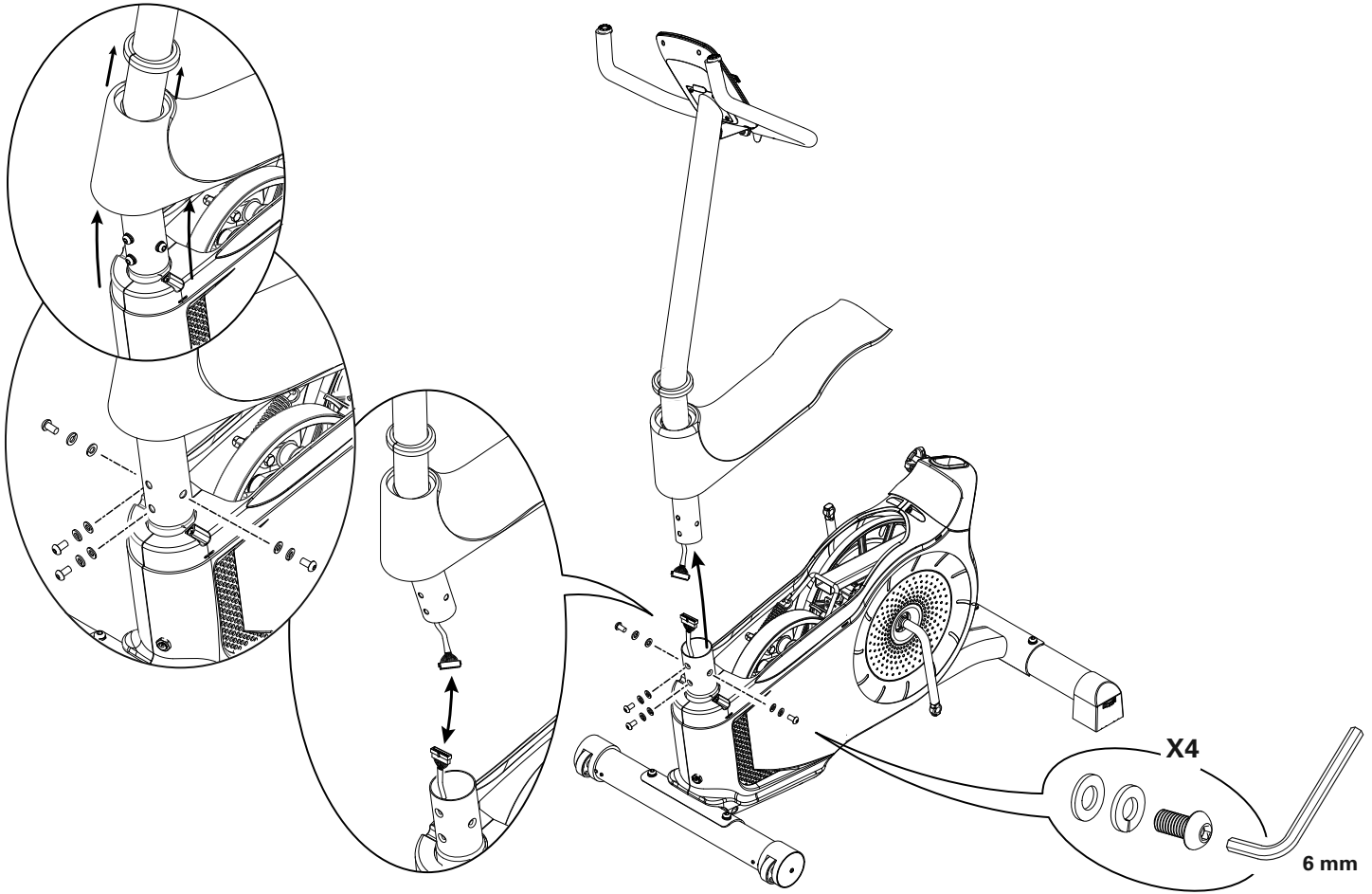

4. Using a 6mm hex wrench, remove the indicated hardware from the Console Mast. Slightly pull the Console Mast upward, and disconnect the cables. Set the hardware, Shroud Cap, and Upper Shroud safely aside for reassembly. Discard the old Console Mast.

NOTICE: Do not pinch or cut the cables.
This step may require two people.

5. Flex the edges of the Seat Post Shroud to disengage the inside tabs from the Main Assembly, and remove it.

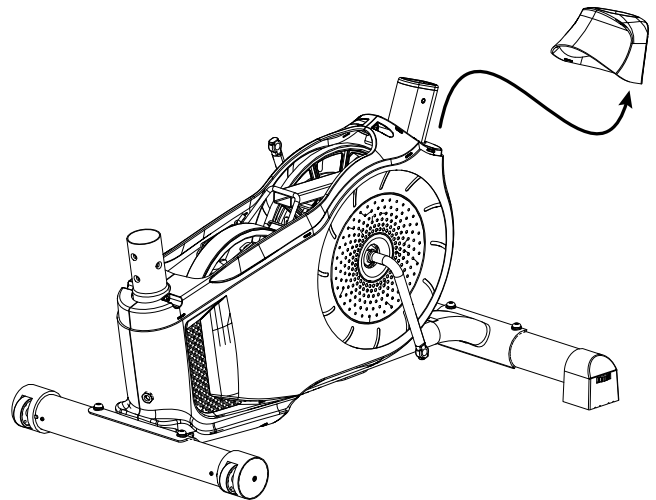

6. Using a #2 Phillips Screwdriver, remove the 6 screws (indicated) that secure the Left Shroud. Remove the bottom screws first, and then the top screws. Slowly remove the Left Shroud. Set the hardware and Shroud safely aside for reassembly.

Note: Find the Power Inlet (A) in the Left Shroud. Disconnect the Power Inlet cable (A1) from the wiring harness (B).

NOTICE: Do not pinch or cut the cables.

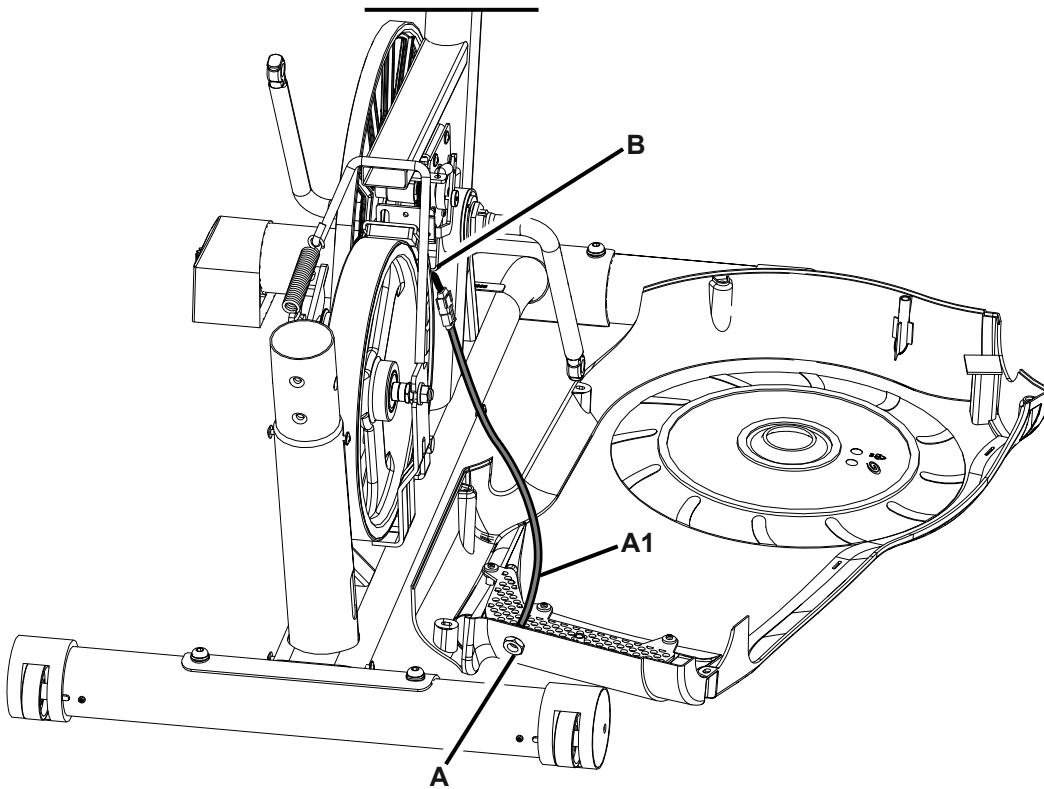
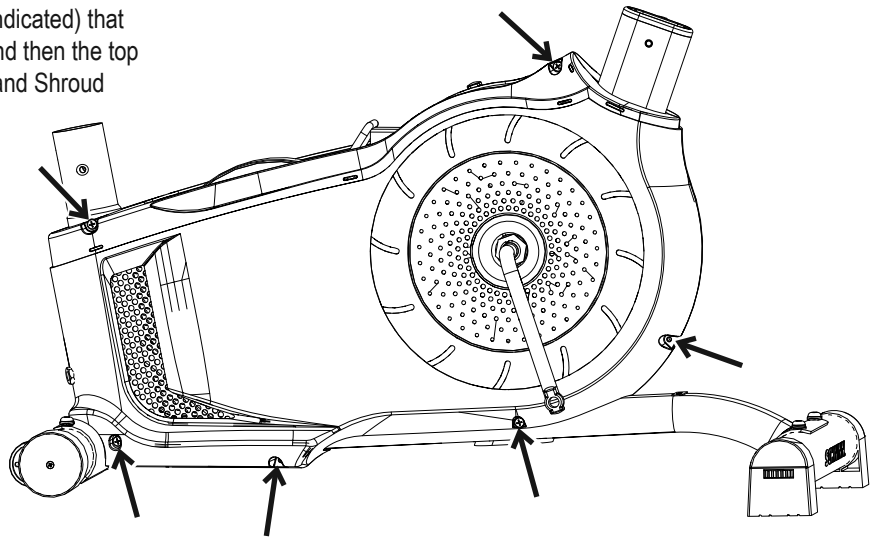

7. Using a #2 Phillips Screwdriver, remove the 2 screws that secure the Right Shroud. Slowly remove the Right Main Shroud. Set the hardware safely aside for reassembly.

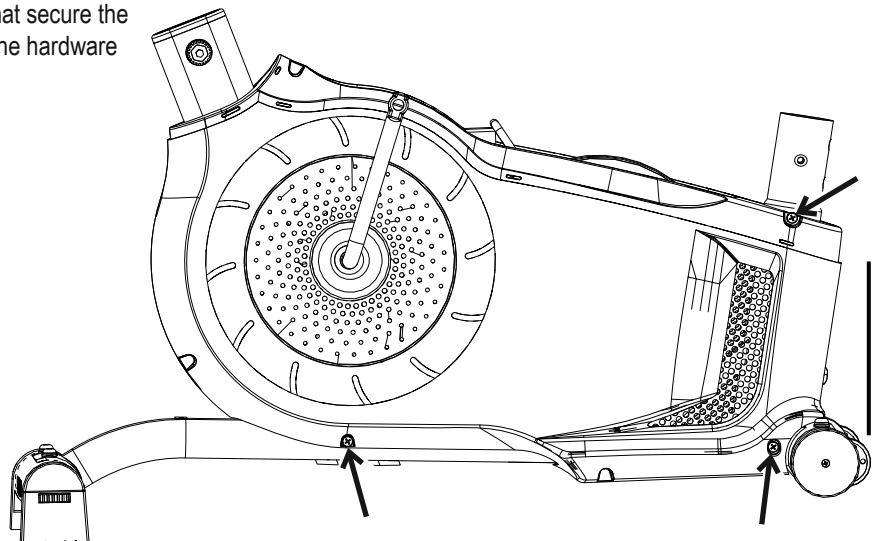

8. Slowly turn the Drive Pulley (A) backward and carefully ease the Drive Belt (B) off the Drive Pulley to the outside.



Be sure to keep fingers clear of all pinch hazards as you turn the Drive Pulley.

9. Using needlenose pliers, carefully release the Belt Tensioner Spring (C1) from the hook (D) on the frame.

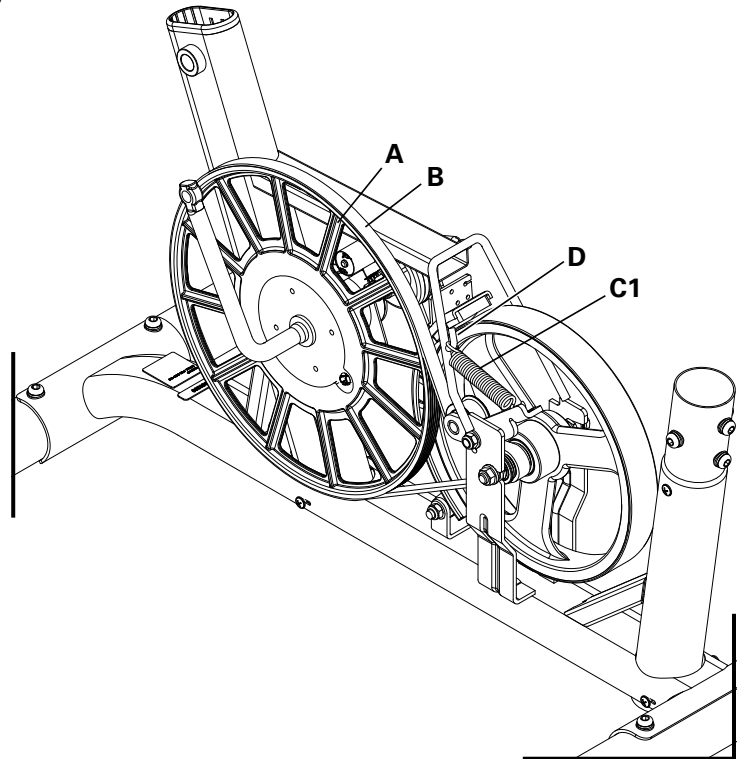

10. Loosen and remove the Locknut (E), Bumper (F) and Bracket (G) from the Pulley Shaft Assembly (H).

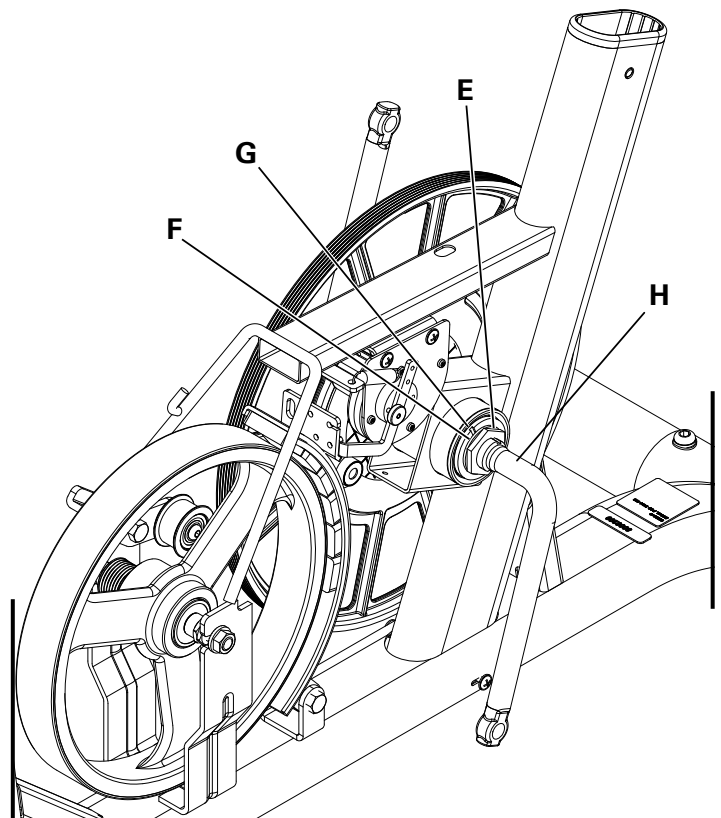

11. Carefully pull the Pulley Shaft Assembly (H) until it works out of the Frame and releases the Washer (J), Bumper (K), Bearings (L) and Bearing Brackets (M).

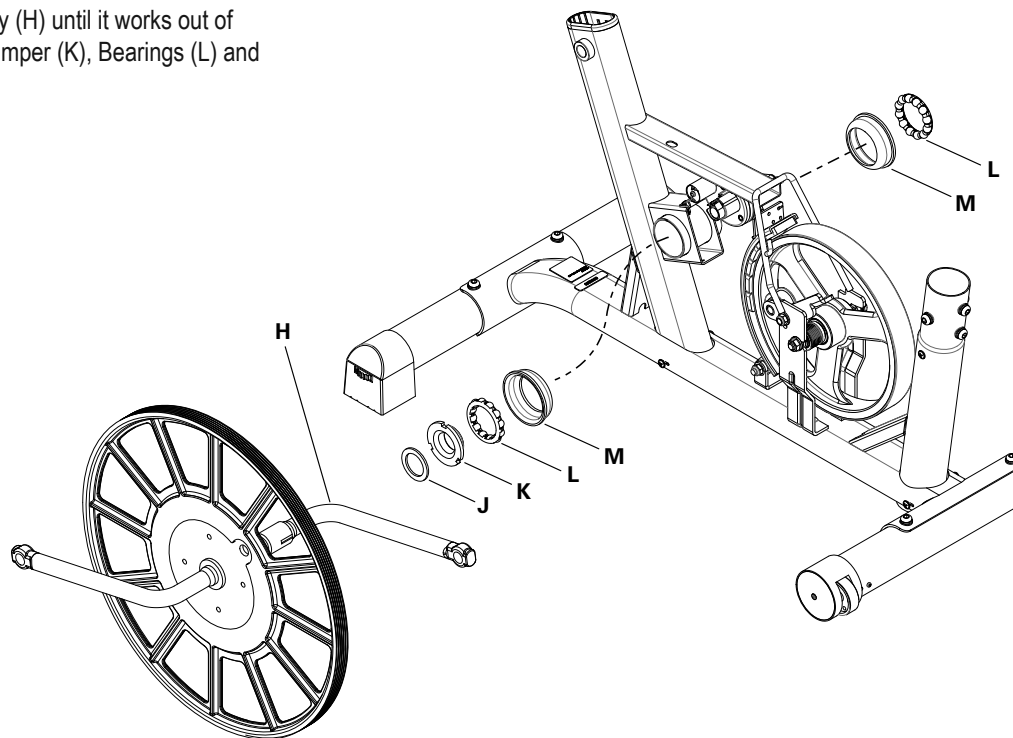

12. Installation is the reverse procedure.

NOTICE: Do not overtighten the crank hardware as this can damage the bearings. Use these torque specs:
 Bracket (G)—approx. 8Nm (6lb-ft)
 Locknut (E)—approx. 25Nm (18.5 lb-ft)

13. Put the Drive Belt (B) onto the Drive Pulley (A). Make sure the Drive Belt is aligned on the Flywheel pulley (N), Belt Tensioner (C) and Drive Pulley. Be sure that the upper portion of the Drive Belt (B) is under the bearings on the Belt Tensioner (C).

14. Using the needlenose pliers, reattach the Belt Tensioner spring (C1). Make sure that the belt tension is correct. Refer to the "Belt Tension Adjustment" section in this manual.

Note: This step may require two people.

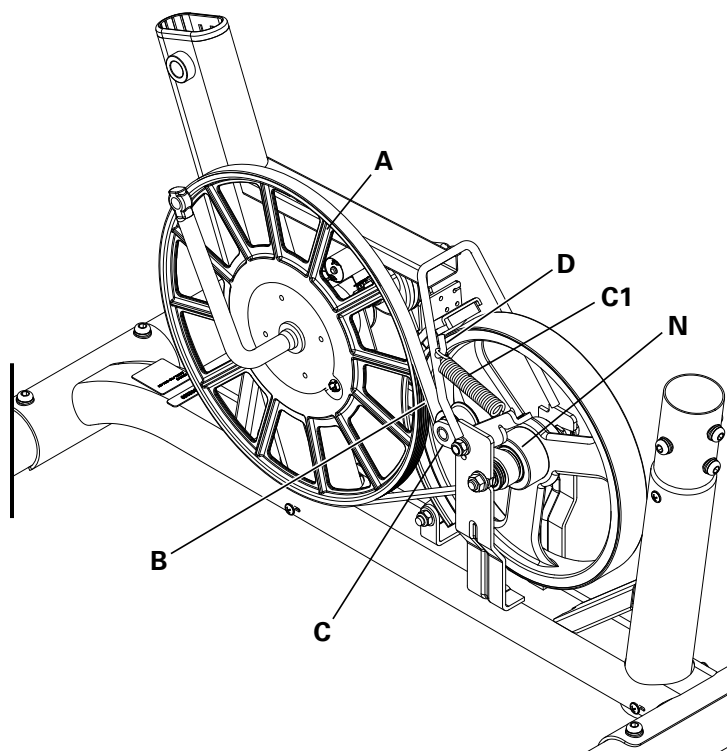

15. Installation is the reverse procedure. Put the Left Shroud in position first to align the screws for the Right Shroud. Install the top screws first.

Note: Self-tapping screws attach the Shrouds to the Frame.

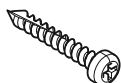

NOTICE: Be sure not to pinch or cut any cables. Be sure the tabs in the Top Shroud snap into the Main Assembly.

16. Attach the Pedals. Start the Pedals by hand, and then fully tighten them with the Pedal Wrench. The Pedals must be fully tightened.

! If the threads strip due to improper installation, then the Pedals can disengage from the bike and/or break while under usage, which can result in serious injury to the user.

Note: The Left Pedal is reverse-threaded. Be sure to attach Pedals on the correct side of the Bike. Orientation is based from a seated position on the bike. The Left Pedal has an "L", the Right Pedal an "R".

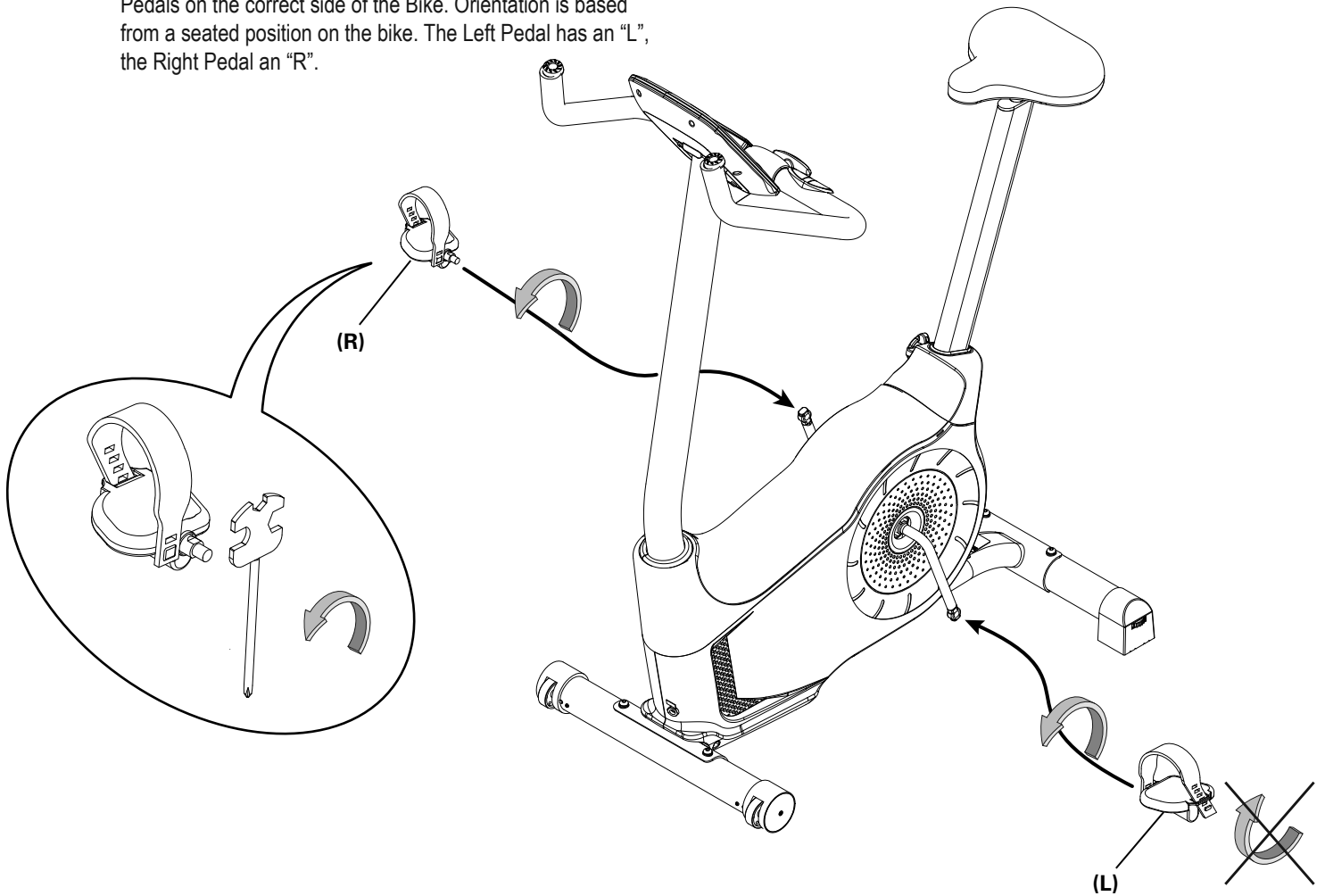

17. Final Inspection

Inspect your machine to ensure that all hardware is tight and components are properly assembled.

! Do not use until the machine has been fully assembled and inspected for correct performance in accordance with the Owner's Manual.

NOTICE: This document provides instructions for the replacement of the Heart Rate Cable in the Console Mast on the Schwinn™ 230 / 510R Recumbent Bikes.

If you need assistance, please contact Customer Service (if purchased in US/Canada) or your local distributor (if purchased outside US/Canada). To find your local distributor, go to: www.nautilusinternational.com

 **This icon means a potentially hazardous situation which, if not avoided, could result in death or serious injury. Read and understand all Warnings on this machine.**

Nautilus, Inc., www.NautilusInc.com, 5415 Centerpoint Parkway, Groveport, OH 43125 U.S.A. - Customer Service: North America (800) 605-3369, csnls@nautilus.com | outside U.S. www.nautilusinternational.com | Printed in China | © 2022 Nautilus, Inc. | Schwinn and the Schwinn logo are trademarks owned or licensed by Nautilus, Inc., registered or otherwise protected by common law in the United States and other nations. | **ORIGINAL DOCUMENT - ENGLISH VERSION ONLY**

Important Safety Instructions - Before servicing or using this equipment, obey the following warnings:

 **This icon means a potentially hazardous situation which, if not avoided, could result in death or serious injury. Read and understand all Warnings on this machine.**

Disconnect all power to the machine before you service it.

- Read and understand the Part Replacement Procedure before working on the machine. Failure to obey the instructions and safety warnings could cause injury to the service technician or bystanders.
- Keep bystanders and children away from the product being serviced at all times.
- Make sure that the repair is done in an appropriate work space away from foot traffic and exposure to bystanders.
- Some components of the equipment can be heavy or awkward. Enlist the service of a second person when you do maintenance steps involving these components. Do not try to do heavy or awkward steps on your own.
- If replacement parts are necessary, use only genuine Nautilus replacement parts and hardware. Failure to use genuine replacement parts can cause a risk to users, keep the machine from operating correctly and void the warranty.
- Be sure that all warning stickers and instructional placards applied to the product stay present and in good condition when doing maintenance or replacing components. If at any time the Warning labels become loose, unreadable or dislodged, replace the labels. If purchased in US/Canada, contact Customer Service for replacement labels. If purchased outside US/Canada, contact your local distributor for them.
- Do not try to change the design or functionality of the machine being serviced as this can adversely affect user safety.
- Do not use the machine until all shrouds, instructions, warning labels and correct functionality have been verified and tested for correct performance.

•SAVE THESE INSTRUCTIONS.

Tools Required (not included)

#2 Phillips screwdriver

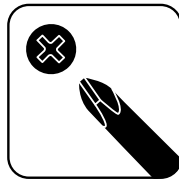

5' (152 cm) length of string

Small flathead screwdriver



6mm hex wrench



! Disconnect all power to the machine before you service it.

Note: Your machine may not match the image. For reference only.

1. Remove the four screws that attach the Console to the Mast. Carefully lift the Console off the Mast.

2. Disconnect the Data Cable and Heart Rate Cable from the back of the Console, and remove it.

Note: Do not let the cables fall down inside the Mast. This step may require two people.

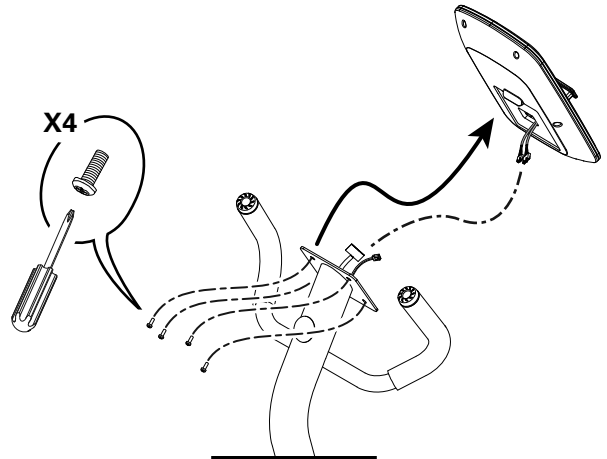

3. Gently remove the Shroud Cap from the Upper Shroud, and remove it from the Console Mast.

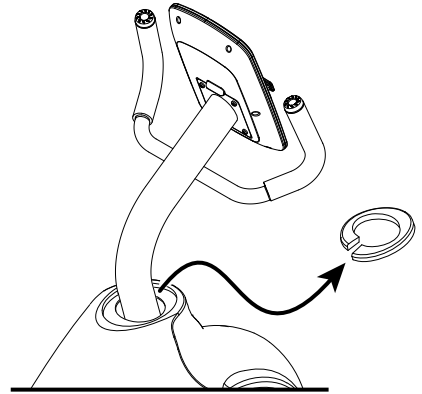

4. Flex the edges of the Upper Shroud to disengage the inside tabs from the Main Assembly, and slide it up the Console Mast.

5. Using a 6mm hex wrench, remove the indicated hardware from the Console Mast. Slightly pull the Console Mast upward, and disconnect the cables. Set the hardware and Upper Shroud safely aside for reassembly. Discard the old Console Mast.

NOTICE: Do not pinch or cut the cables.
This step may require two people.

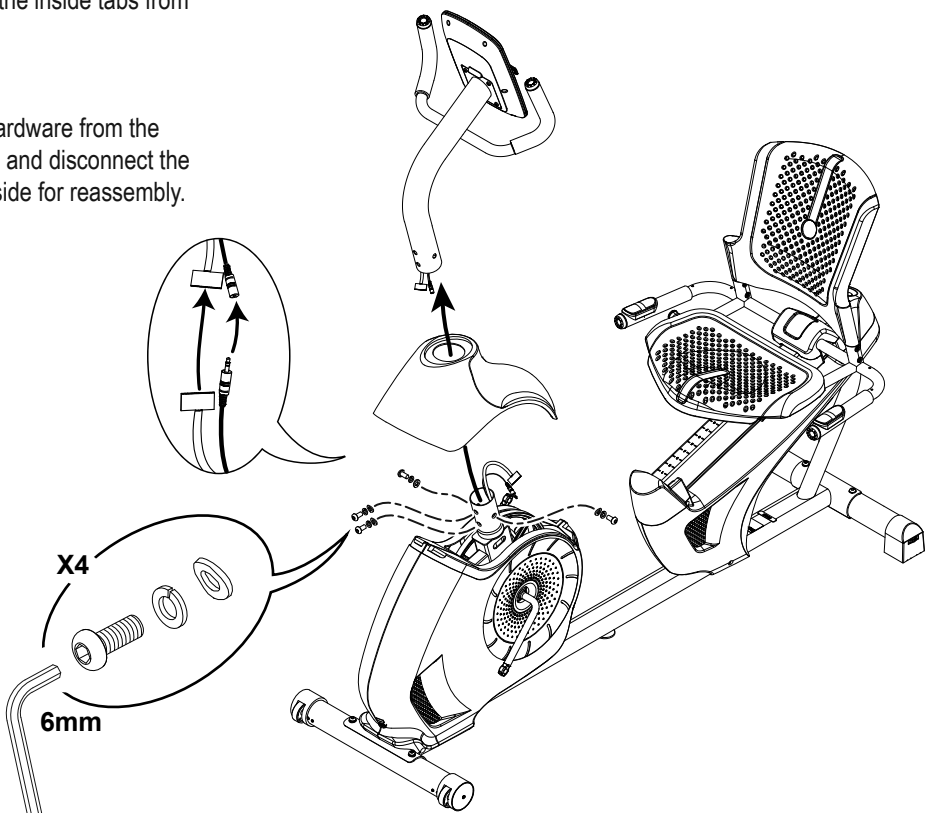

6. Tie a length of string to the end of the old Heart Rate Cable at the base of the Console Mast. Hold the other end of the old Heart Rate Cable and carefully pull it out of the Console Mast so that the string extends through the length of the Console Mast. Untie the string and discard the old Heart Rate Cable.

NOTICE: Hold the Data Cable so that you do not pull it out of the Mast. Do not pinch or cut the Data cable.

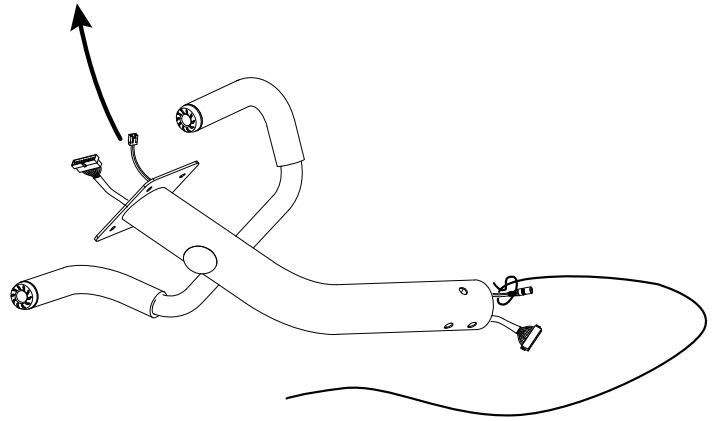

7. Tie the end of the string at the base of the Console Mast to appropriate end of the replacement Heart Rate Cable. Hold the other end of the string and carefully pull the new Heart Rate Cable through the Console Mast.

NOTICE: Hold the Data Cable so that you do not pull it out of the Mast. Do not pinch or cut the cables.

8. Untie the string from the new Heart Rate Cable, and connect the cable to the Heart Rate Cable from the Main Frame.

NOTICE: Do not pinch or cut the cables. This step may require two people.

9. Put the Console Mast (with the Upper Shroud) back in position in the Main Frame, and reinstall the Hardware.

Note: Do not let the cables fall down inside the Console Mast.

NOTICE: Be sure not to pinch or cut any cables. This step may require two people.

10. Slide the Upper Shroud back into position and reinstall the Shroud Cap.

NOTICE: Be sure the tabs in the Upper Shroud snap into the Main Assembly.

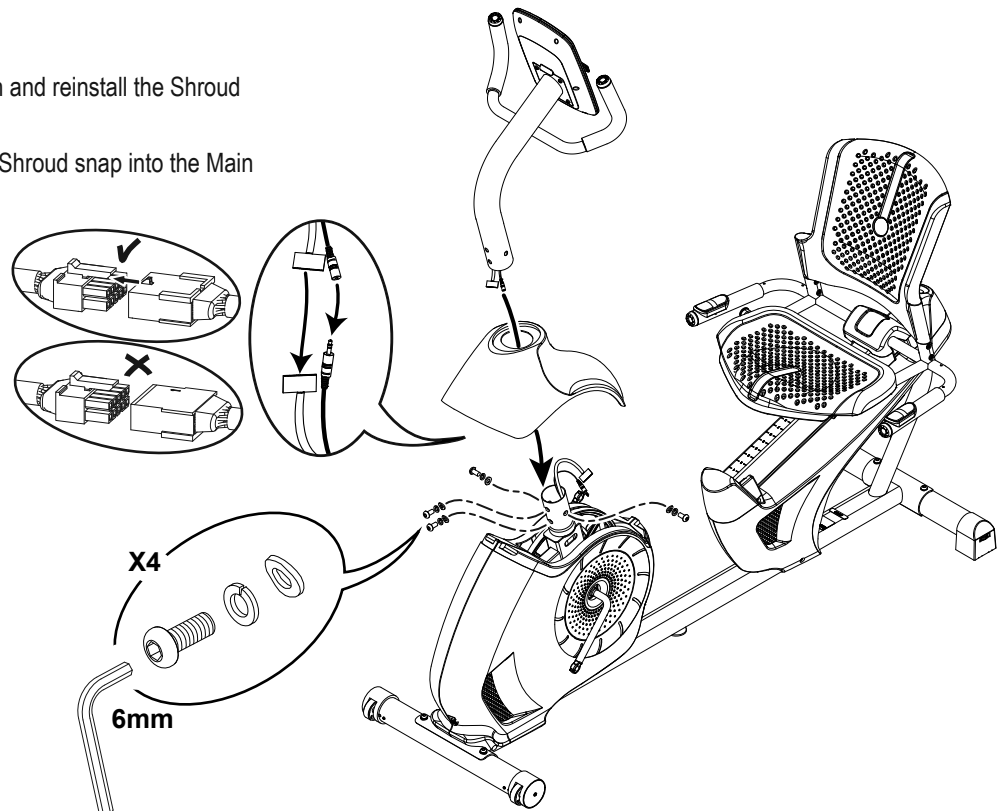

11. Connect the cables to the back of the Console and attach the Console to the Console Mast with the screws from Step 2.

NOTICE: Do not pinch or cut the cables. Align the clips on the cable connectors and make sure the connectors lock.

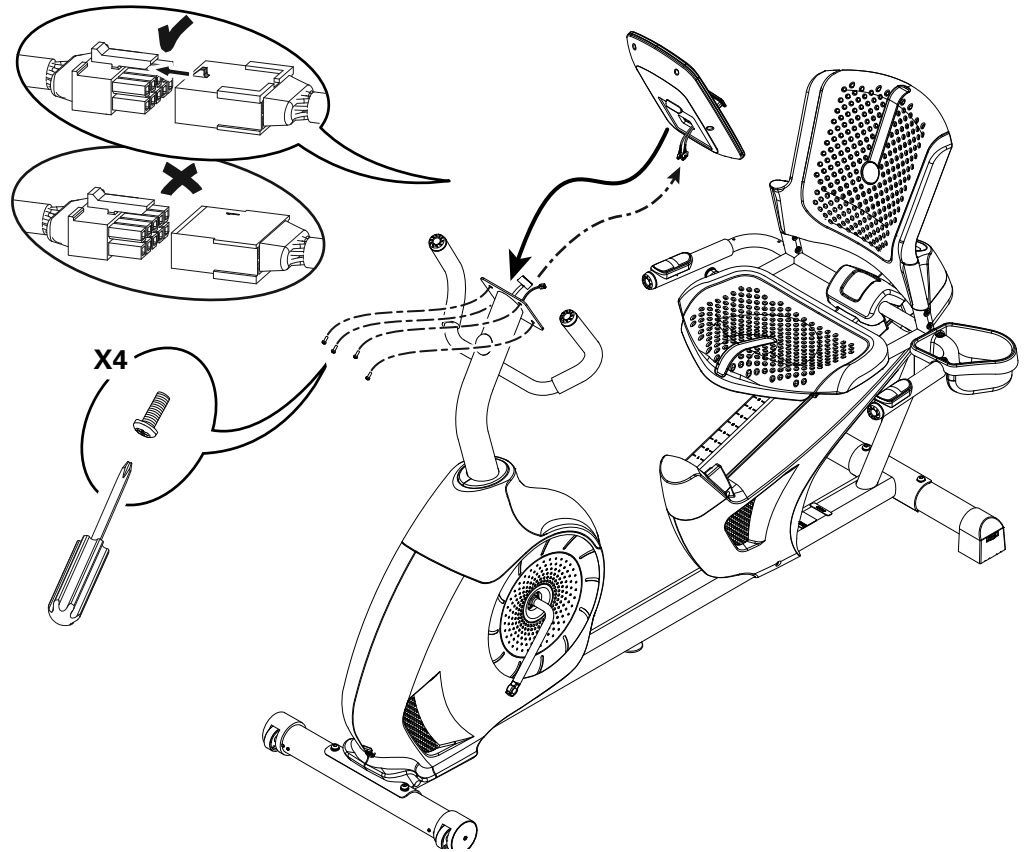

12. Installation is the reverse procedure.

Note: Do not pinch or cut the cables.

13. Discard the old parts according to your local guidelines and regulations.

14. Final Inspection

Inspect your machine to ensure that all hardware is tight and components are properly assembled.

! Do not use until the machine has been fully assembled and inspected for correct performance in accordance with the Owner's Manual.

NOTICE: This document provides instructions for the replacement of the Shrouds on the Schwinn™ 130 / 510U Upright Bikes and 230 / 510R Recumbent Bikes.

If you need assistance, please contact Customer Service (if purchased in US/Canada) or your local distributor (if purchased outside US/Canada). To find your local distributor, go to: www.nautilusinternational.com

! This icon means a potentially hazardous situation which, if not avoided, could result in death or serious injury. Read and understand all Warnings on this machine.

Nautilus, Inc., www.NautilusInc.com, 5415 Centerpoint Parkway, Groveport, OH 43125 U.S.A. - Customer Service: North America (800) 605-3369, csnls@nautilus.com | outside U.S. www.nautilusinternational.com | Printed in China | © 2022 Nautilus, Inc. | Schwinn and the Schwinn logo are trademarks owned or licensed by Nautilus, Inc., registered or otherwise protected by common law in the United States and other nations. | **ORIGINAL DOCUMENT - ENGLISH VERSION ONLY**

Important Safety Instructions - Before servicing or using this equipment, obey the following warnings:

! This icon means a potentially hazardous situation which, if not avoided, could result in death or serious injury. Read and understand all Warnings on this machine.

Disconnect all power to the machine before you service it.

- Read and understand the Part Replacement Procedure before working on the machine. Failure to obey the instructions and safety warnings could cause injury to the service technician or bystanders.
- Keep bystanders and children away from the product being serviced at all times.
- Make sure that the repair is done in an appropriate work space away from foot traffic and exposure to bystanders.
- Some components of the equipment can be heavy or awkward. Enlist the service of a second person when you do maintenance steps involving these components. Do not try to do heavy or awkward steps on your own.
- If replacement parts are necessary, use only genuine Nautilus replacement parts and hardware. Failure to use genuine replacement parts can cause a risk to users, keep the machine from operating correctly and void the warranty.
- Be sure that all warning stickers and instructional placards applied to the product stay present and in good condition when doing maintenance or replacing components. If at any time the Warning labels become loose, unreadable or dislodged, replace the labels. If purchased in US/Canada, contact Customer Service for replacement labels. If purchased outside US/Canada, contact your local distributor for them.
- Do not try to change the design or functionality of the machine being serviced as this can adversely affect user safety.
- Do not use the machine until all shrouds, instructions, warning labels and correct functionality have been verified and tested for correct performance.

• SAVE THESE INSTRUCTIONS.

Tools Required (not included)

Pedal wrench or 15mm open end wrench



 **Disconnect all power to the machine before you service it.**

Note: Your machine may not match the image. For reference only.

1. Loosen and remove the Pedals.

Note: The Left Pedal is reverse-threaded. Orientation is based from a seated position on the bike. The Left Pedal has an "L", the Right Pedal an "R".

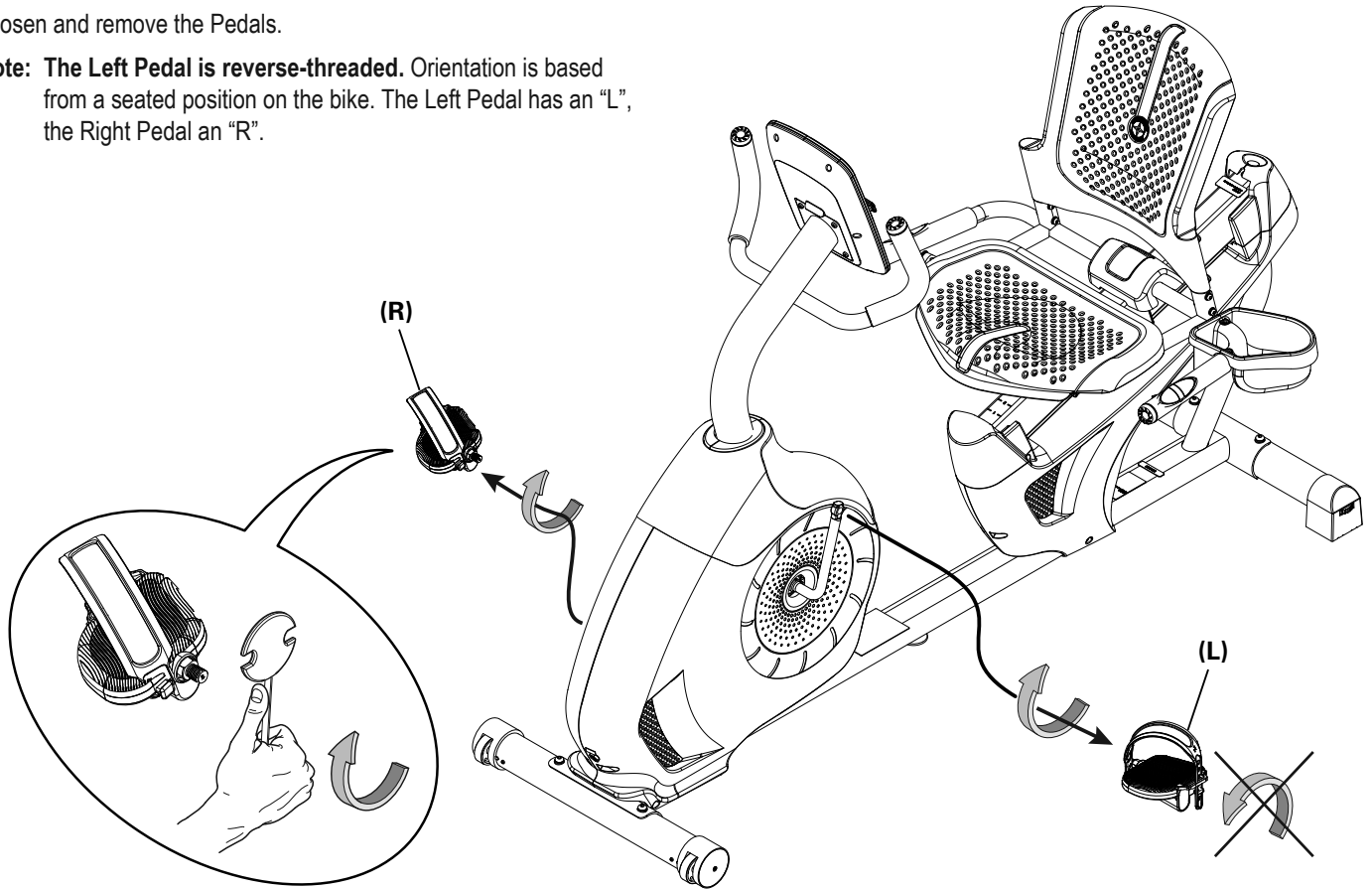

2. Attach the Pedals. Start the Pedals by hand, and then fully tighten them with the Pedal Wrench. The Pedals must be fully tightened.

! If the threads strip due to improper installation, then the Pedals can disengage from the bike and/or break while under usage, which can result in serious injury to the user.

Note: The Left Pedal is reverse-threaded. Be sure to attach Pedals on the correct side of the Bike. Orientation is based from a seated position on the bike. The Left Pedal has an “L”, the Right Pedal an “R”.

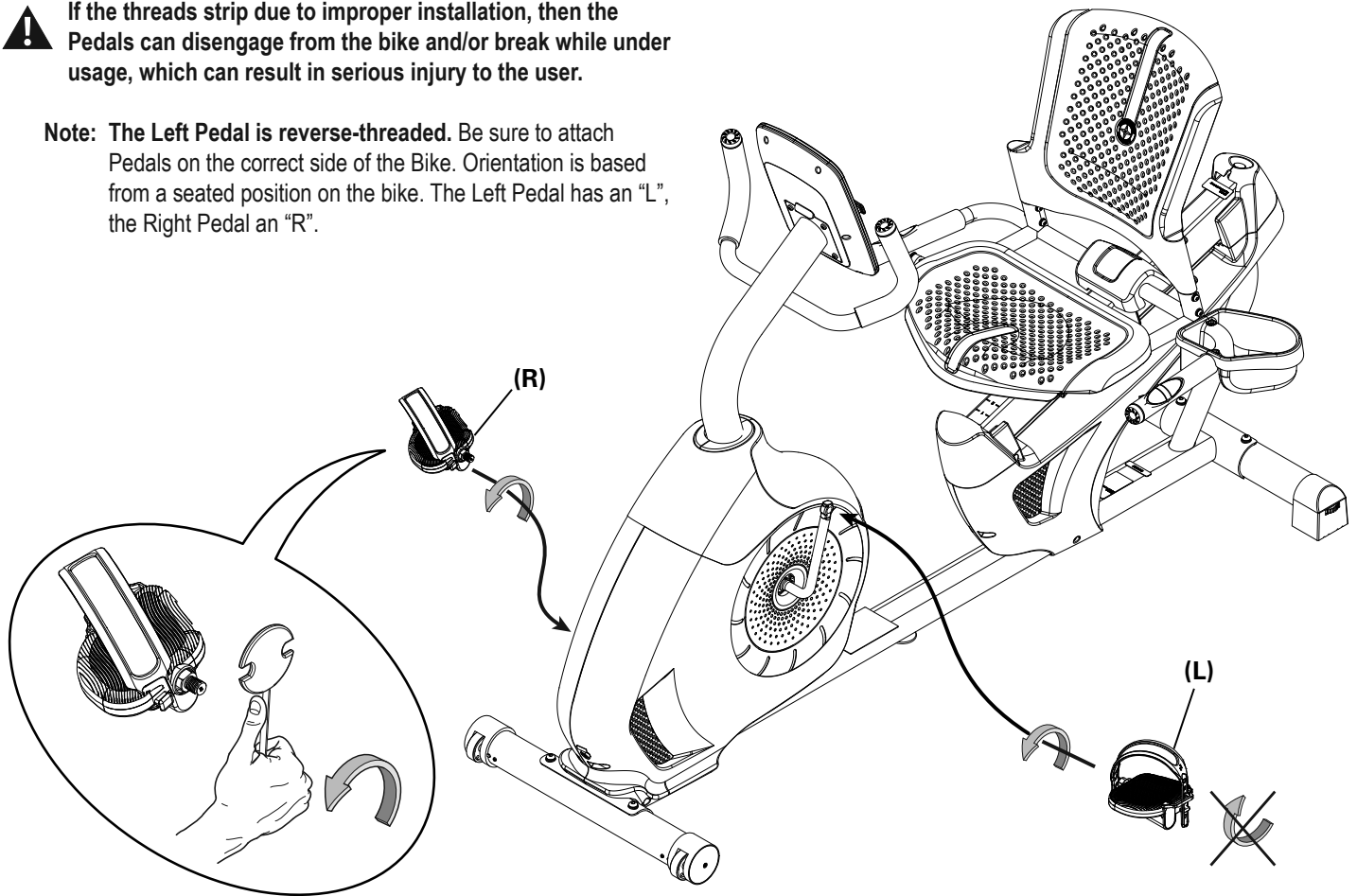

3. Final Inspection

Inspect your machine to ensure that all hardware is tight and components are properly assembled.

! Do not use until the machine has been fully assembled and inspected for correct performance in accordance with the Owner's Manual.

NOTICE: This document provides instructions for the replacement of the Power Inlet on the Schwinn™ 130 / 510U Upright Bikes and 230 / 510R Recumbent Bikes.

If you need assistance, please contact Customer Service (if purchased in US/Canada) or your local distributor (if purchased outside US/Canada). To find your local distributor, go to: www.nautilusinternational.com

 **This icon means a potentially hazardous situation which, if not avoided, could result in death or serious injury. Read and understand all Warnings on this machine.**

Nautilus, Inc., www.NautilusInc.com, 5415 Centerpoint Parkway, Groveport, OH 43125 U.S.A. - Customer Service: North America (800) 605-3369, csnls@nautilus.com | outside U.S. www.nautilusinternational.com | Printed in China | © 2022 Nautilus, Inc. | Schwinn and the Schwinn logo are trademarks owned or licensed by Nautilus, Inc., registered or otherwise protected by common law in the United States and other nations. | **ORIGINAL DOCUMENT - ENGLISH VERSION ONLY**

Important Safety Instructions - Before servicing or using this equipment, obey the following warnings:

 **This icon means a potentially hazardous situation which, if not avoided, could result in death or serious injury. Read and understand all Warnings on this machine.**

Disconnect all power to the machine before you service it.

- Read and understand the Part Replacement Procedure before working on the machine. Failure to obey the instructions and safety warnings could cause injury to the service technician or bystanders.
- Keep bystanders and children away from the product being serviced at all times.
- Make sure that the repair is done in an appropriate work space away from foot traffic and exposure to bystanders.
- Some components of the equipment can be heavy or awkward. Enlist the service of a second person when you do maintenance steps involving these components. Do not try to do heavy or awkward steps on your own.
- If replacement parts are necessary, use only genuine Nautilus replacement parts and hardware. Failure to use genuine replacement parts can cause a risk to users, keep the machine from operating correctly and void the warranty.
- Be sure that all warning stickers and instructional placards applied to the product stay present and in good condition when doing maintenance or replacing components. If at any time the Warning labels become loose, unreadable or dislodged, replace the labels. If purchased in US/Canada, contact Customer Service for replacement labels. If purchased outside US/Canada, contact your local distributor for them.
- Do not try to change the design or functionality of the machine being serviced as this can adversely affect user safety.
- Do not use the machine until all shrouds, instructions, warning labels and correct functionality have been verified and tested for correct performance.

• SAVE THESE INSTRUCTIONS.

Tools Required (not included)

#2 Phillips screwdriver



17mm open end wrench
or adjustable wrench



Small flathead screwdriver



Pedal wrench or 15mm open end
wrench



! Disconnect all power to the machine before you service it.

Note: Your machine may not match the image. For reference only.

1. Loosen and remove the Pedals.

Note: The Left Pedal is reverse-threaded. Orientation is based from a seated position on the bike. The Left Pedal has an "L", the Right Pedal an "R".

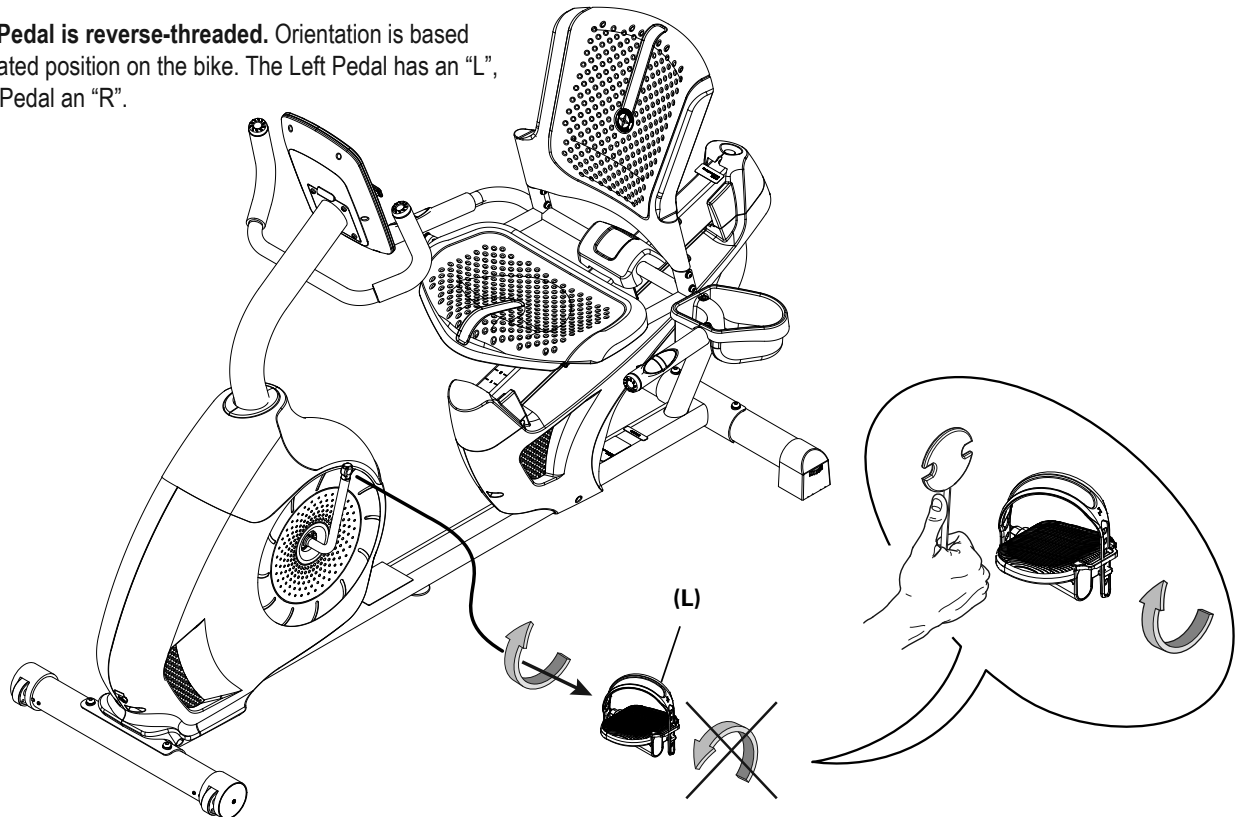

2. Gently remove the Shroud Cap from the Upper Shroud, and remove it from the Console Mast.

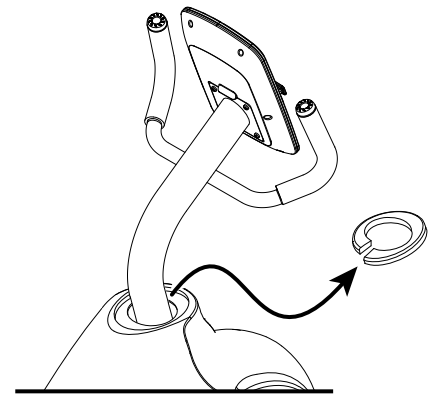

3. Flex the edges of the Upper Shroud to disengage the inside tabs from the Main Assembly, and slide it up the Console Mast.

4. Using a 6mm hex wrench, remove the indicated hardware from the Console Mast. Slightly pull the Console Mast upward, and disconnect the cables. Set the hardware and Upper Shroud safely aside for reassembly. Discard the old Console Mast.

NOTICE: Do not pinch or cut the cables.
This step may require two people.

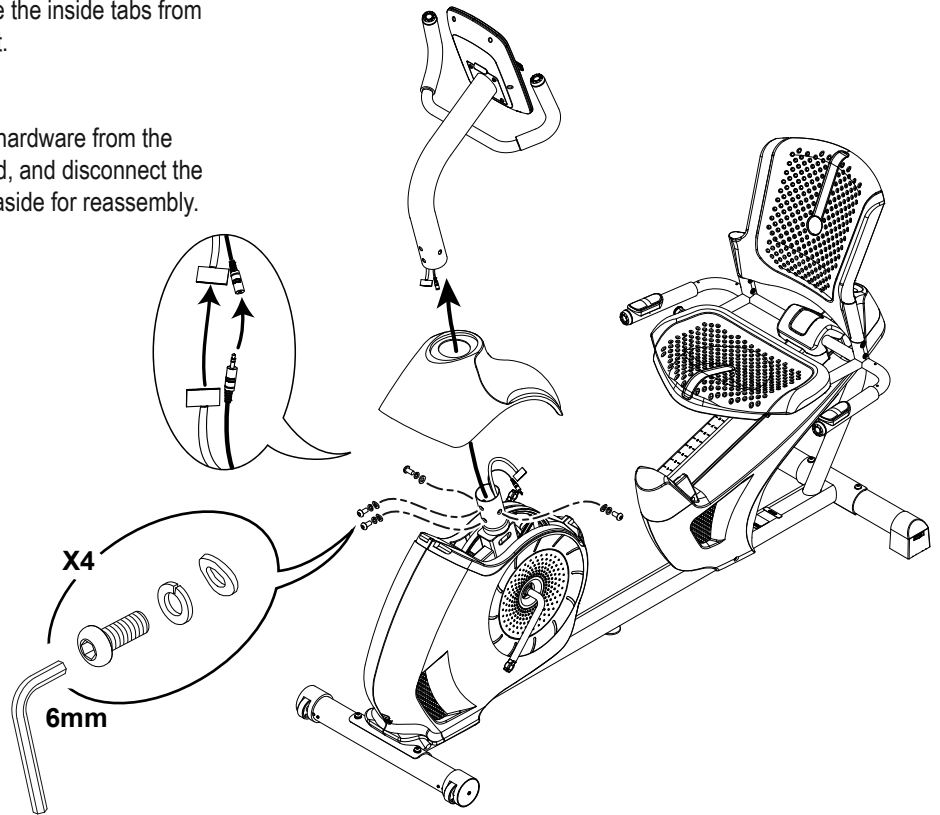

5. Using a #2 Phillips Screwdriver, remove the 6 screws (indicated) that secure the Left Main Shroud. Remove the bottom screws first, and then the top screws. Set the hardware safely aside for reassembly. Slowly remove the Left Main Shroud.

Note: The Power Inlet Cable (A1) is attached to the inside of the Left Main Shroud. Be sure not to pinch or cut the cable by placing the Left Main Shroud close to the side of the machine.

NOTICE: Do not pinch or cut the cables.

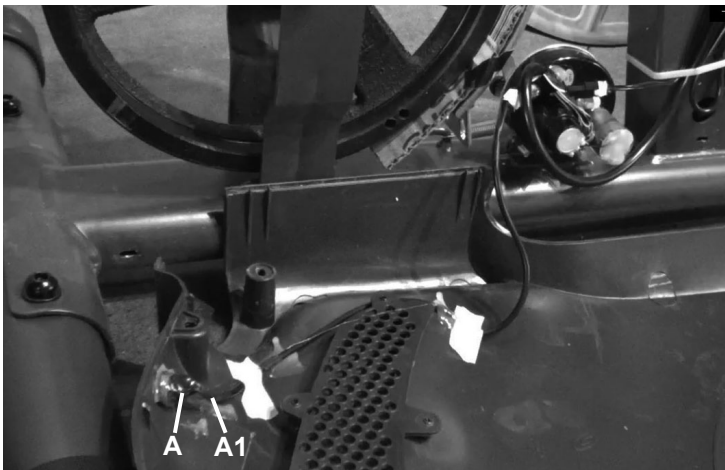
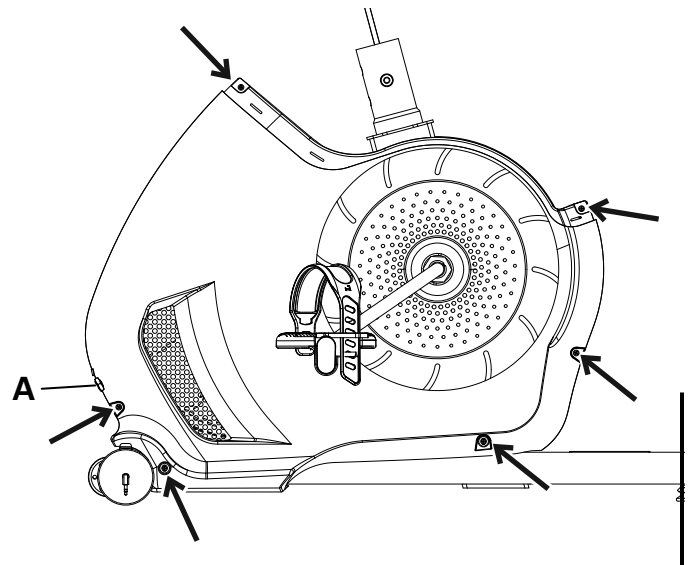

6. Carefully disconnect the Power Inlet Cable (A1) in the Shroud from the wiring harness (B) on the motor. **Upright bike**

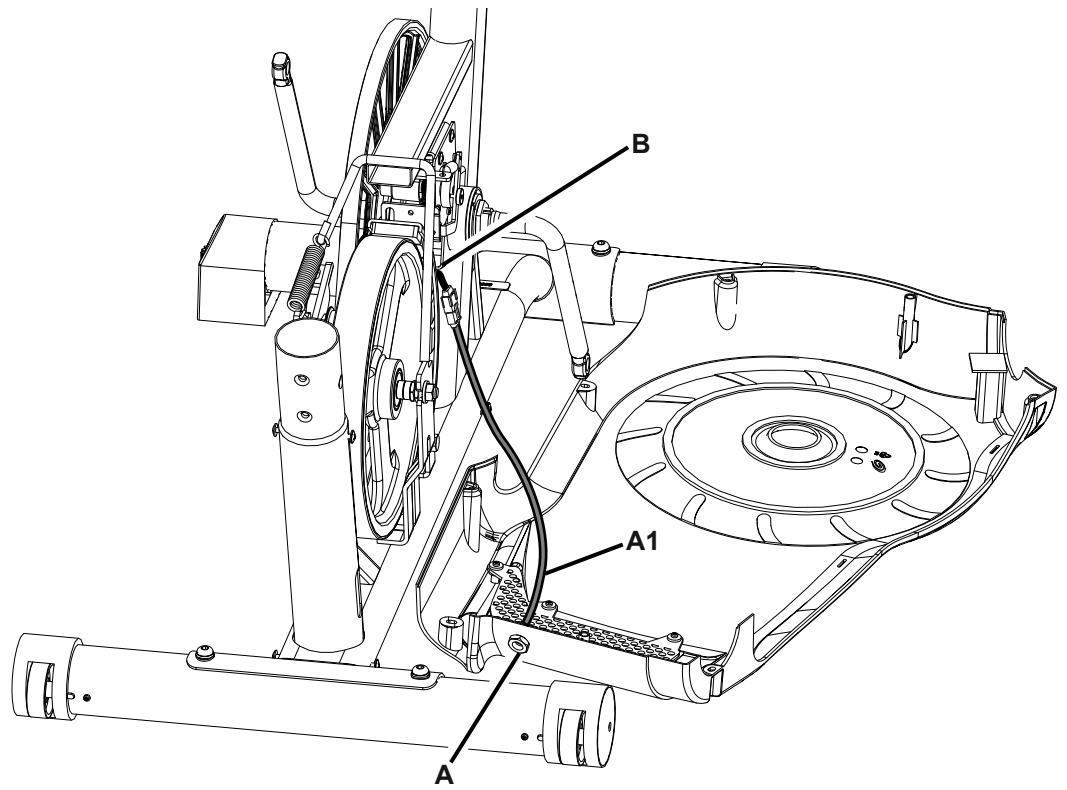

Recumbent bike

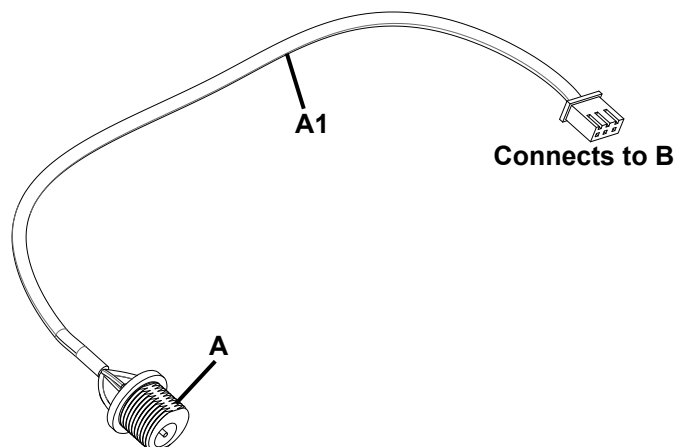
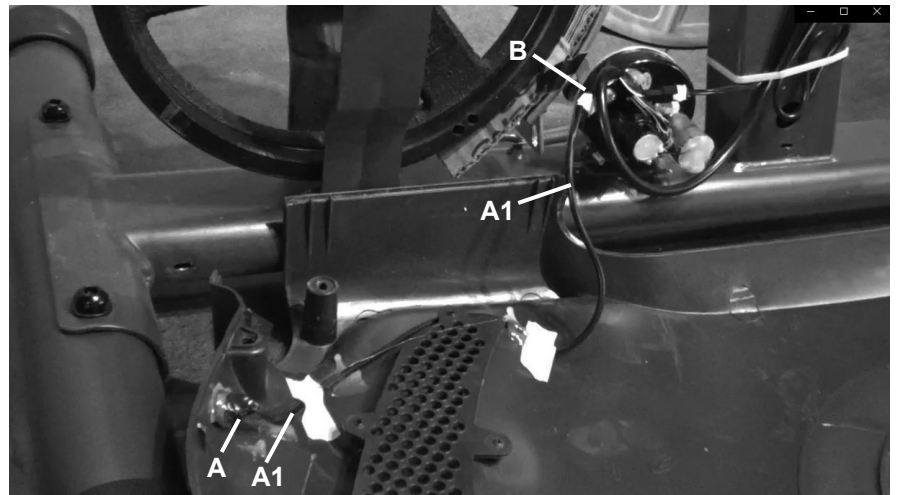

7. Loosen and remove the thin Nut from the Power Inlet (C) on the outside of the Shroud.

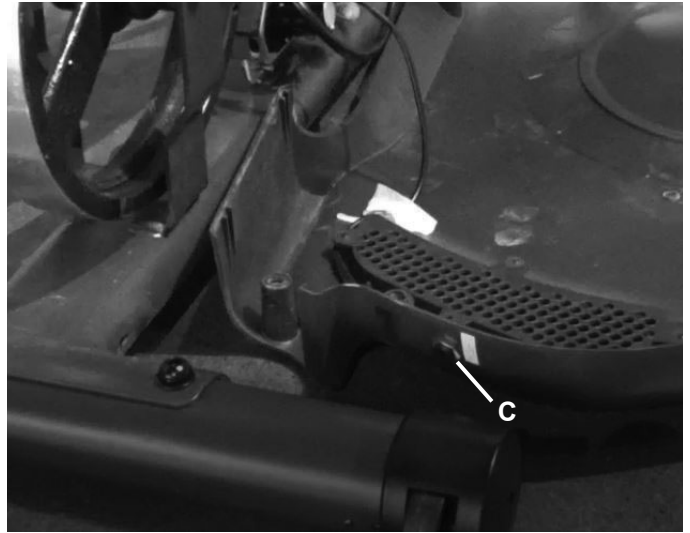

8. Pull the Power Inlet plug (A) out of the hole toward the inside of the Shroud. Discard the old Power Inlet assembly.

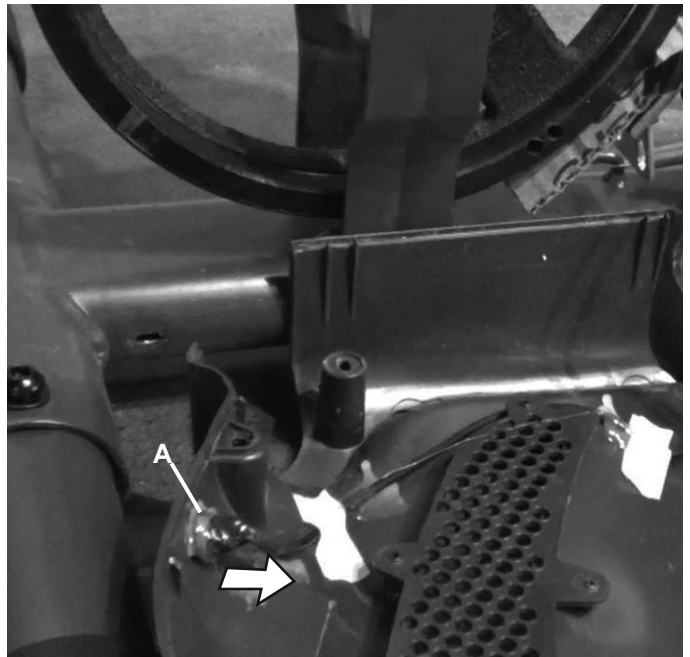

9. Installation is the reverse procedure.

NOTICE: Do not pinch or cut the cables. Be sure the Power Inlet plug is seated evenly in the hole.

10. Installation is the reverse procedure. Put the Left Shroud in position first to align the screws for the Right Shroud. Install the top screws first.

Note: Self-tapping screws attach the Shrouds to the Frame.

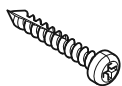

NOTICE: Do not pinch or cut the cables. Be sure the tabs in the Top Shroud snap into the Main Assembly.

11. Attach the Pedals. Start the Pedals by hand, and then fully tighten them with the Pedal Wrench. The Pedals must be fully tightened.

! If the threads strip due to improper installation, then the Pedals can disengage from the bike and/or break while under usage, which can result in serious injury to the user.

Note: The Left Pedal is reverse-threaded. Be sure to attach Pedals on the correct side of the Bike. Orientation is based from a seated position on the bike. The Left Pedal has an "L", the Right Pedal an "R".

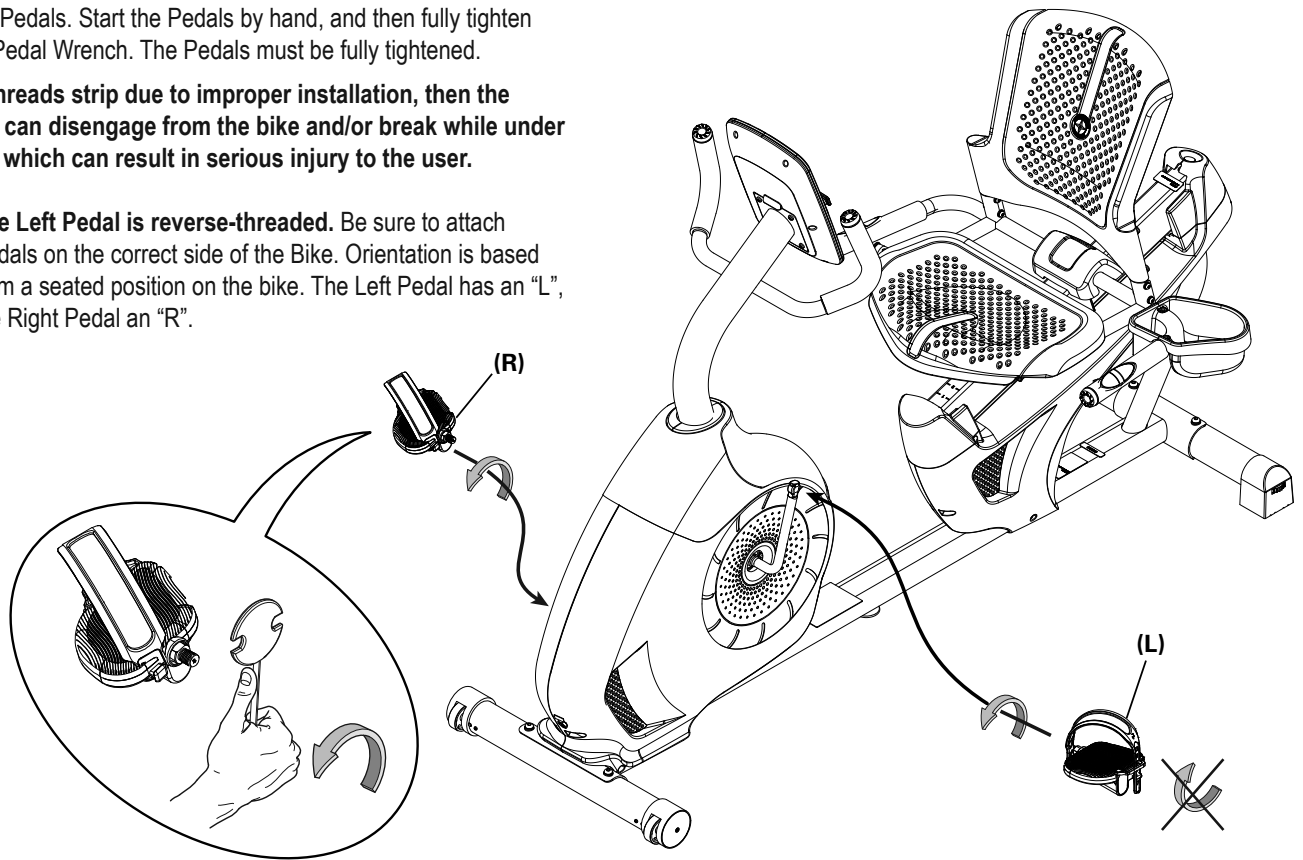

12. Final Inspection

Inspect your machine to ensure that all hardware is tight and components are properly assembled.

! Do not use until the machine has been fully assembled and inspected for correct performance in accordance with the Owner's Manual.

NOTICE: This document provides instructions for the replacement of the RPM Sensor (Speed Sensor) on the Schwinn™ 130 / 510U Upright Bikes and 230 / 510R Recumbent Bikes.

If you need assistance, please contact Customer Service (if purchased in US/Canada) or your local distributor (if purchased outside US/Canada). To find your local distributor, go to: www.nautilusinternational.com

! This icon means a potentially hazardous situation which, if not avoided, could result in death or serious injury. Read and understand all Warnings on this machine.

Nautilus, Inc., www.NautilusInc.com, 5415 Centerpoint Parkway, Groveport, OH 43125 U.S.A. - Customer Service: North America (800) 605-3369, csnls@nautilus.com | outside U.S. www.nautilusinternational.com | Printed in China | © 2022 Nautilus, Inc. | Schwinn and the Schwinn logo are trademarks owned or licensed by Nautilus, Inc., registered or otherwise protected by common law in the United States and other nations. | **ORIGINAL DOCUMENT - ENGLISH VERSION ONLY**

Important Safety Instructions - Before servicing or using this equipment, obey the following warnings:

! This icon means a potentially hazardous situation which, if not avoided, could result in death or serious injury. Read and understand all Warnings on this machine.

Disconnect all power to the machine before you service it.

- Read and understand the Part Replacement Procedure before working on the machine. Failure to obey the instructions and safety warnings could cause injury to the service technician or bystanders.
- Keep bystanders and children away from the product being serviced at all times.
- Make sure that the repair is done in an appropriate work space away from foot traffic and exposure to bystanders.
- Some components of the equipment can be heavy or awkward. Enlist the service of a second person when you do maintenance steps involving these components. Do not try to do heavy or awkward steps on your own.
- If replacement parts are necessary, use only genuine Nautilus replacement parts and hardware. Failure to use genuine replacement parts can cause a risk to users, keep the machine from operating correctly and void the warranty.
- Be sure that all warning stickers and instructional placards applied to the product stay present and in good condition when doing maintenance or replacing components. If at any time the Warning labels become loose, unreadable or dislodged, replace the labels. If purchased in US/Canada, contact Customer Service for replacement labels. If purchased outside US/Canada, contact your local distributor for them.
- Do not try to change the design or functionality of the machine being serviced as this can adversely affect user safety.
- Do not use the machine until all shrouds, instructions, warning labels and correct functionality have been verified and tested for correct performance.

• SAVE THESE INSTRUCTIONS.

Tools Required (not included)

#2 Phillips screwdriver

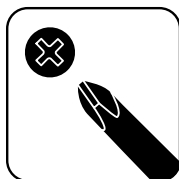

Utility knife or scissors to cut ziptie

Ziptie

Small flathead screwdriver



Pedal wrench or 15mm open end wrench



! Disconnect all power to the machine before you service it.

Note: Your machine may not match the image. For reference only.

1. Loosen and remove the Pedals.

Note: The Left Pedal is reverse-threaded. Orientation is based from a seated position on the bike. The Left Pedal has an "L", the Right Pedal an "R".

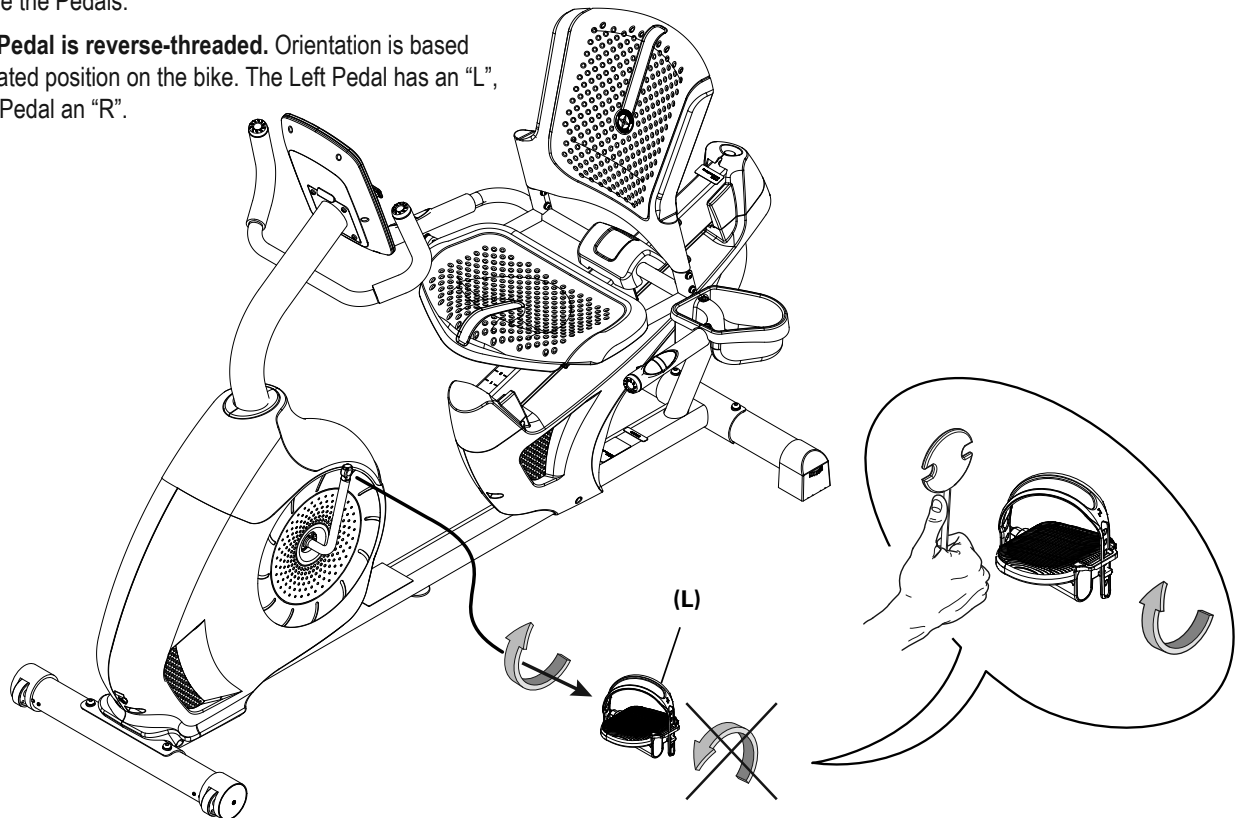

2. Gently remove the Mast Gasket from the Upper Shroud, and remove it from the Console Mast.

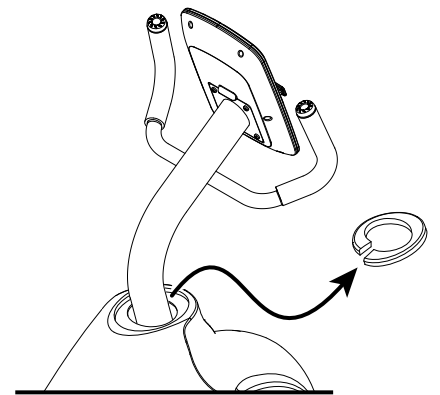

3. Flex the edges of the Shroud Cap to disengage the inside tabs from the Main Assembly, and slide it up the Console Mast.

4. Using a 6mm hex wrench, remove the indicated hardware from the Console Mast. Slightly pull the Console Mast upward, and disconnect the cables. Set the hardware, Shroud Cap, and Upper Shroud safely aside for reassembly. Discard the old Console Mast.

NOTICE: Do not pinch or cut the cables.
This step may require two people.

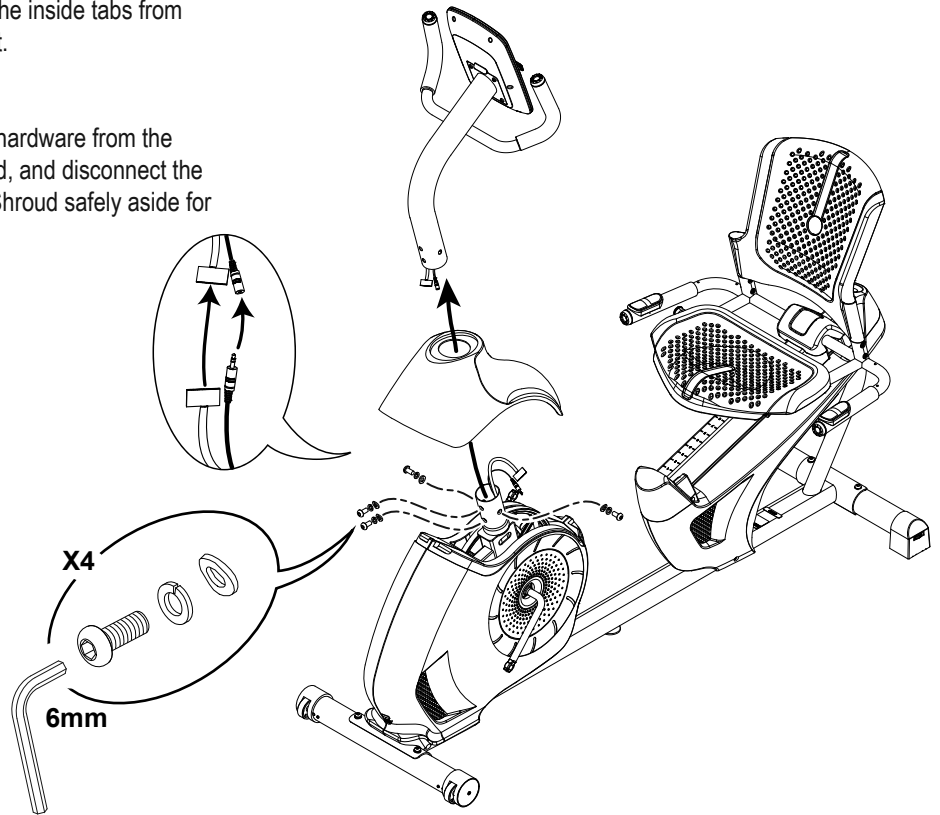

5. Using a #2 Phillips Screwdriver, remove the 6 screws (indicated) that secure the Left Main Shroud. Remove the bottom screws first, and then the top screws. Set the hardware safely aside for reassembly. Slowly remove the Left Main Shroud.

Note: The Power Inlet Cable (A1) is attached to the inside of the Left Main Shroud. Be sure not to pinch or cut the cable by placing the Left Main Shroud close to the side of the machine.

NOTICE: Do not pinch or cut the cables.

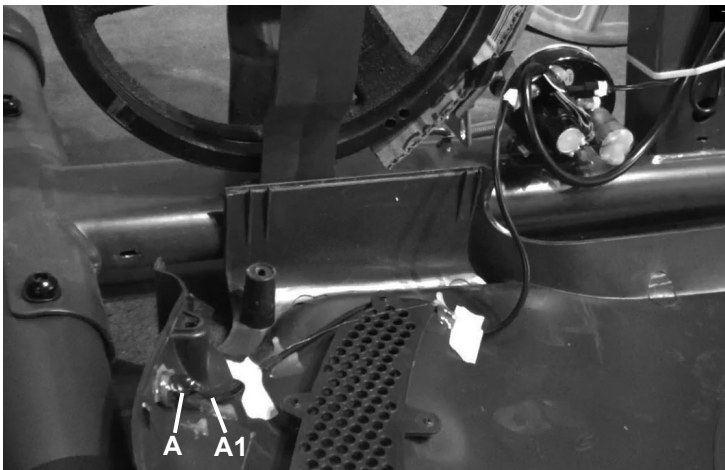
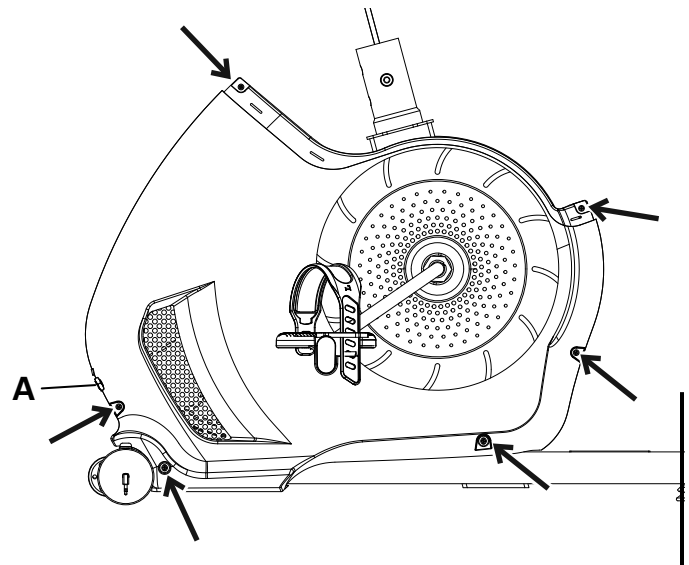

6. Observe the cable routing from the RPM Sensor (C) to the wiring harness (B) on your machine. Carefully disconnect the RPM Sensor cable (C1) from the wiring harness.

7. Remove the hardware that attaches the RPM Sensor (C) to the Main Frame. Carefully remove the old RPM Sensor and cable and discard it.

NOTICE: Do not pinch or cut the cables.

Upright bike

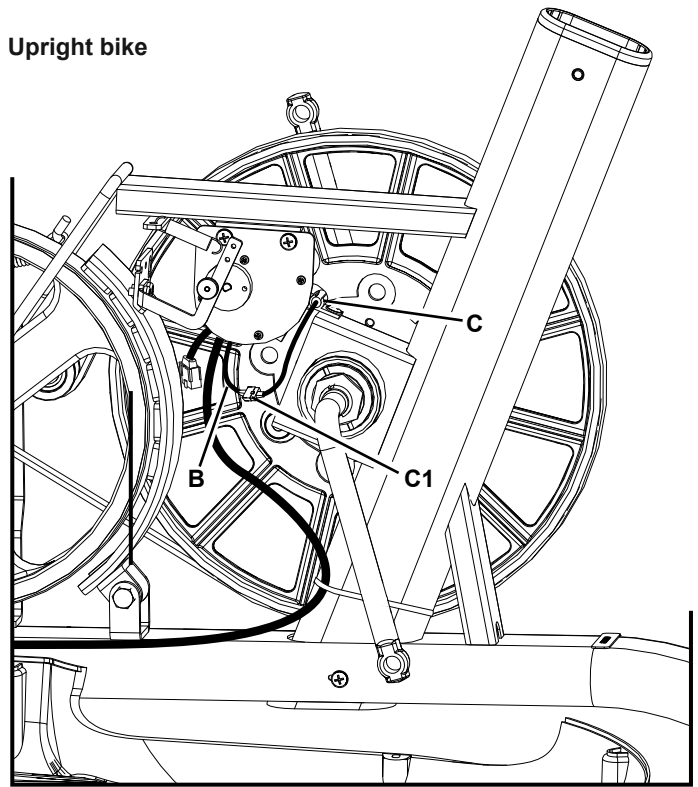

Recumbent bike

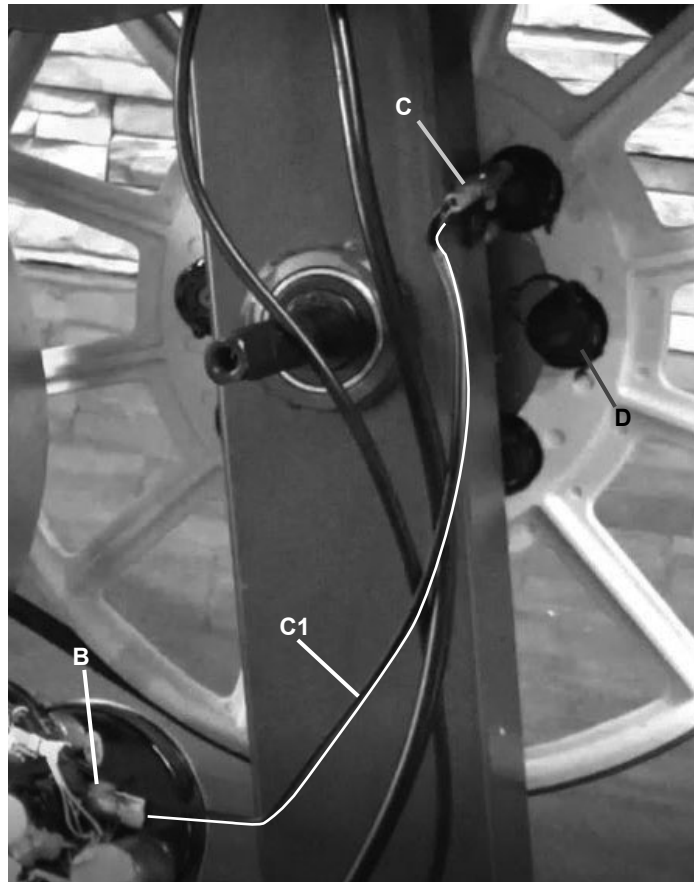

8. Installation is the reverse procedure.

NOTICE: Do not pinch or cut the cables. Be sure the routing for the new RPM Sensor cable (C1) and other wiring is correct to prevent interference from moving parts.

Note: Before fully attaching the Shrouds, verify that the RPM Sensor (C) and Speed Sensor Magnet (D) on the Drive Pulley do not touch.

Note: Self-tapping screws attach the Shrouds to the Frame.

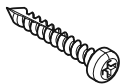

NOTICE: Be sure not to pinch or cut any cables. Be sure the tabs in the Top Shroud snap into the Main Assembly.

9. Attach the Pedals. Start the Pedals by hand, and then fully tighten them with the Pedal Wrench. The Pedals must be fully tightened.

! If the threads strip due to improper installation, then the Pedals can disengage from the bike and/or break while under usage, which can result in serious injury to the user.

Note: The Left Pedal is reverse-threaded. Be sure to attach Pedals on the correct side of the Bike. Orientation is based from a seated position on the bike. The Left Pedal has an "L", the Right Pedal an "R".

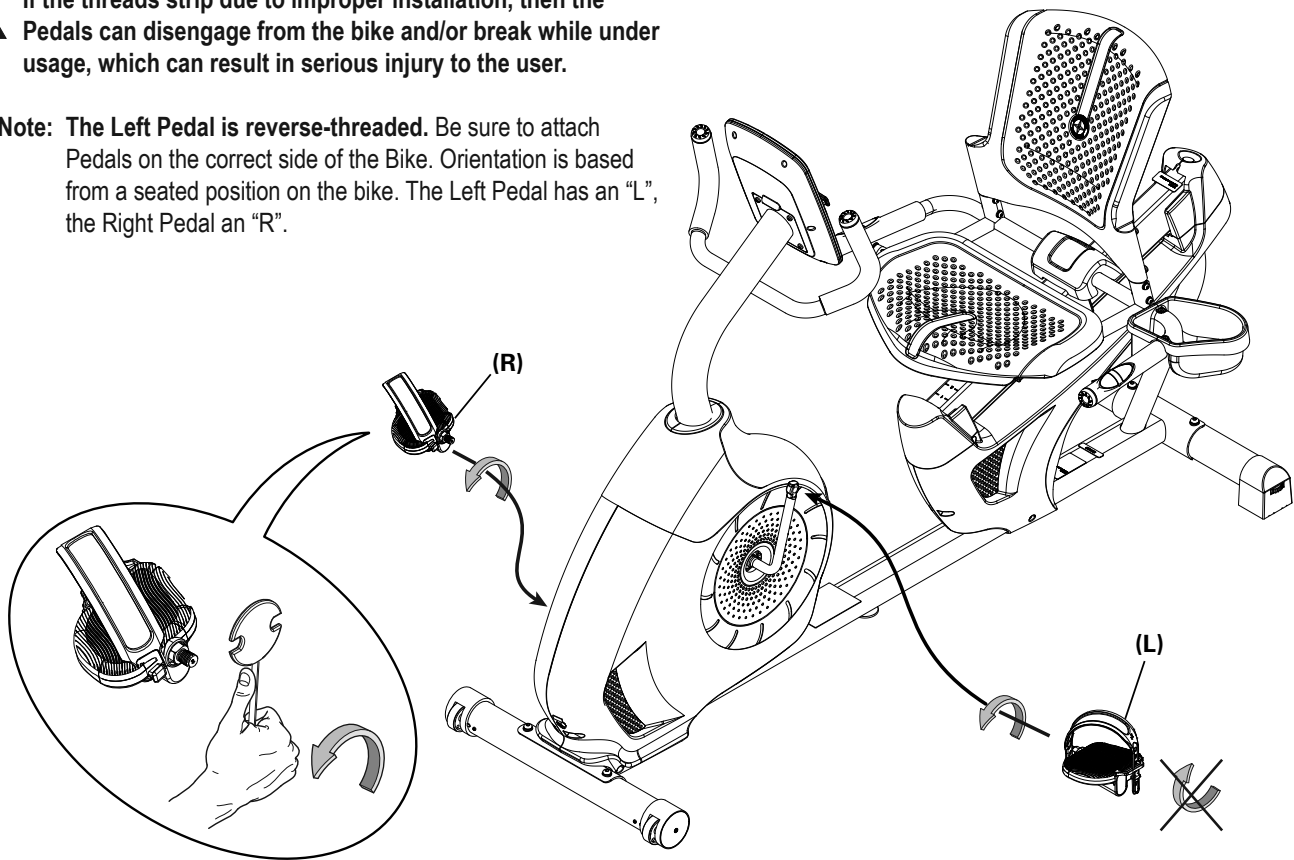

10. Final Inspection

Inspect your machine to ensure that all hardware is tight and components are properly assembled.

! Do not use until the machine has been fully assembled and inspected for correct performance in accordance with the Owner's Manual.

NOTICE: This document provides instructions for the replacement of the Seat Rail and Seat Slider Assembly on the Schwinn™ 230 / 510R Recumbent Bikes.

If you need assistance, please contact Customer Service (if purchased in US/Canada) or your local distributor (if purchased outside US/Canada). To find your local distributor, go to: www.nautilusinternational.com

! This icon means a potentially hazardous situation which, if not avoided, could result in death or serious injury. Read and understand all Warnings on this machine.

Nautilus, Inc., www.NautilusInc.com, 5415 Centerpoint Parkway, Groveport, OH 43125 U.S.A. - Customer Service: North America (800) 605-3369, csnls@nautilus.com | outside U.S. www.nautilusinternational.com | Printed in China | © 2022 Nautilus, Inc. | Schwinn and the Schwinn logo are trademarks owned or licensed by Nautilus, Inc., registered or otherwise protected by common law in the United States and other nations. | **ORIGINAL DOCUMENT - ENGLISH VERSION ONLY**

Important Safety Instructions - Before servicing or using this equipment, obey the following warnings:

! This icon means a potentially hazardous situation which, if not avoided, could result in death or serious injury. Read and understand all Warnings on this machine.

Disconnect all power to the machine before you service it.

- Read and understand the Part Replacement Procedure before working on the machine. Failure to obey the instructions and safety warnings could cause injury to the service technician or bystanders.
- Keep bystanders and children away from the product being serviced at all times.
- Make sure that the repair is done in an appropriate work space away from foot traffic and exposure to bystanders.
- Some components of the equipment can be heavy or awkward. Enlist the service of a second person when you do maintenance steps involving these components. Do not try to do heavy or awkward steps on your own.
- If replacement parts are necessary, use only genuine Nautilus replacement parts and hardware. Failure to use genuine replacement parts can cause a risk to users, keep the machine from operating correctly and void the warranty.
- Be sure that all warning stickers and instructional placards applied to the product stay present and in good condition when doing maintenance or replacing components. If at any time the Warning labels become loose, unreadable or dislodged, replace the labels. If purchased in US/Canada, contact Customer Service for replacement labels. If purchased outside US/Canada, contact your local distributor for them.
- Do not try to change the design or functionality of the machine being serviced as this can adversely affect user safety.
- Do not use the machine until all shrouds, instructions, warning labels and correct functionality have been verified and tested for correct performance.

• SAVE THESE INSTRUCTIONS.

Tools Required (not included)

#2 Phillips screwdriver

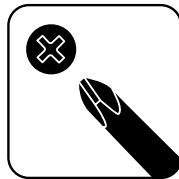

13mm open end wrench

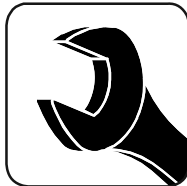

6mm hex wrench
4mm hex wrench





Disconnect all power to the machine before you service it.

Note: Your machine may not match the image. For reference only.

1. Remove the Seat Adjustment Handle from the seat slider assembly. Set the Seat Adjustment Handle safely aside for reassembly.

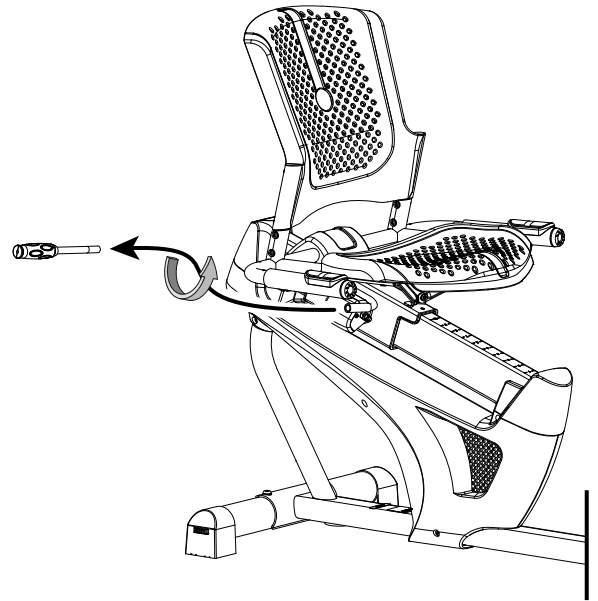

2. Carefully remove the Top Cap from the seat slider bracket, and disconnect the Heart Rate Cables.

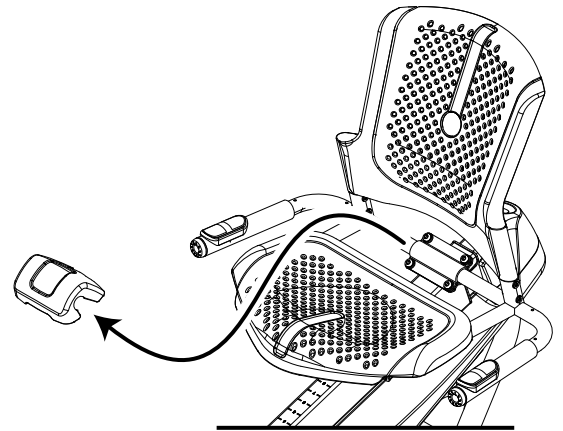

3. Using a #2 Phillips Screwdriver, loosen and remove the hardware that attaches the padded Seat Bottom to the Seat Frame Assembly. Set the hardware safely aside for reassembly.

4. Remove the Seat Bottom from the Seat Frame Assembly and set it safely aside.

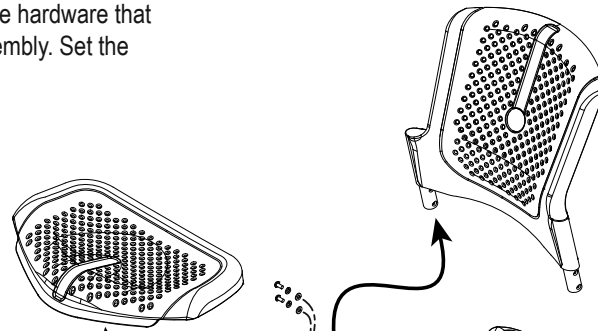

5. Using a 4mm hex wrench, loosen and remove the hardware that attaches the Seat Back to the Seat Frame assembly, and remove the Seat Back. Set the Seat Back and hardware safely aside.

NOTICE: This step may require two people.

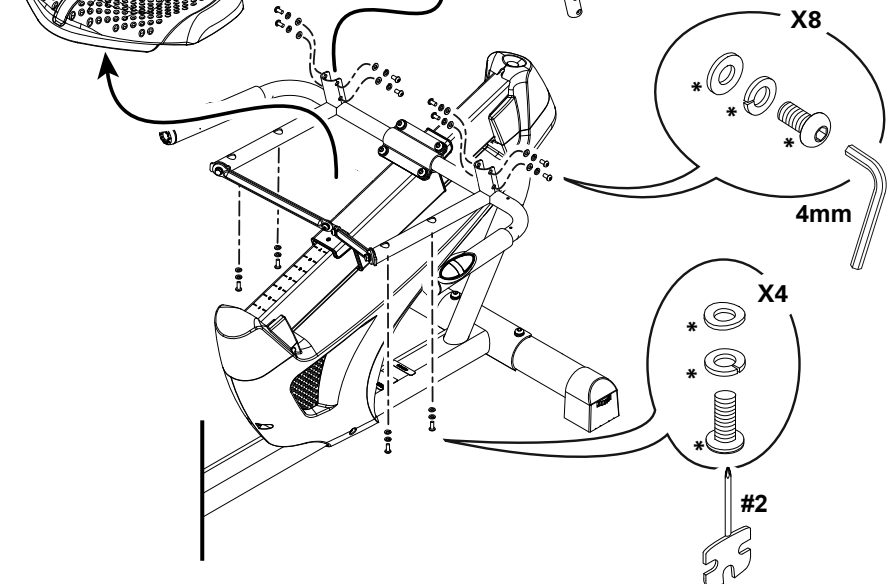

6. Carefully disconnect the Heart Rate Cables.

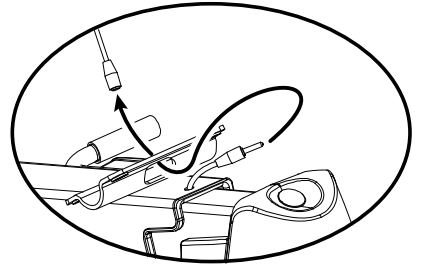

7. Using a 4mm hex wrench, remove the bolts from the bracket arms at the front of the Seat Frame. Using a 6mm hex wrench, remove the 4 bolts from the back of the Seat Frame. Remove the Seat Frame Assembly. Set the hardware and Seat Frame Assembly safely aside.

NOTICE: Be sure not to pinch or cut any cables. This step may require two people.

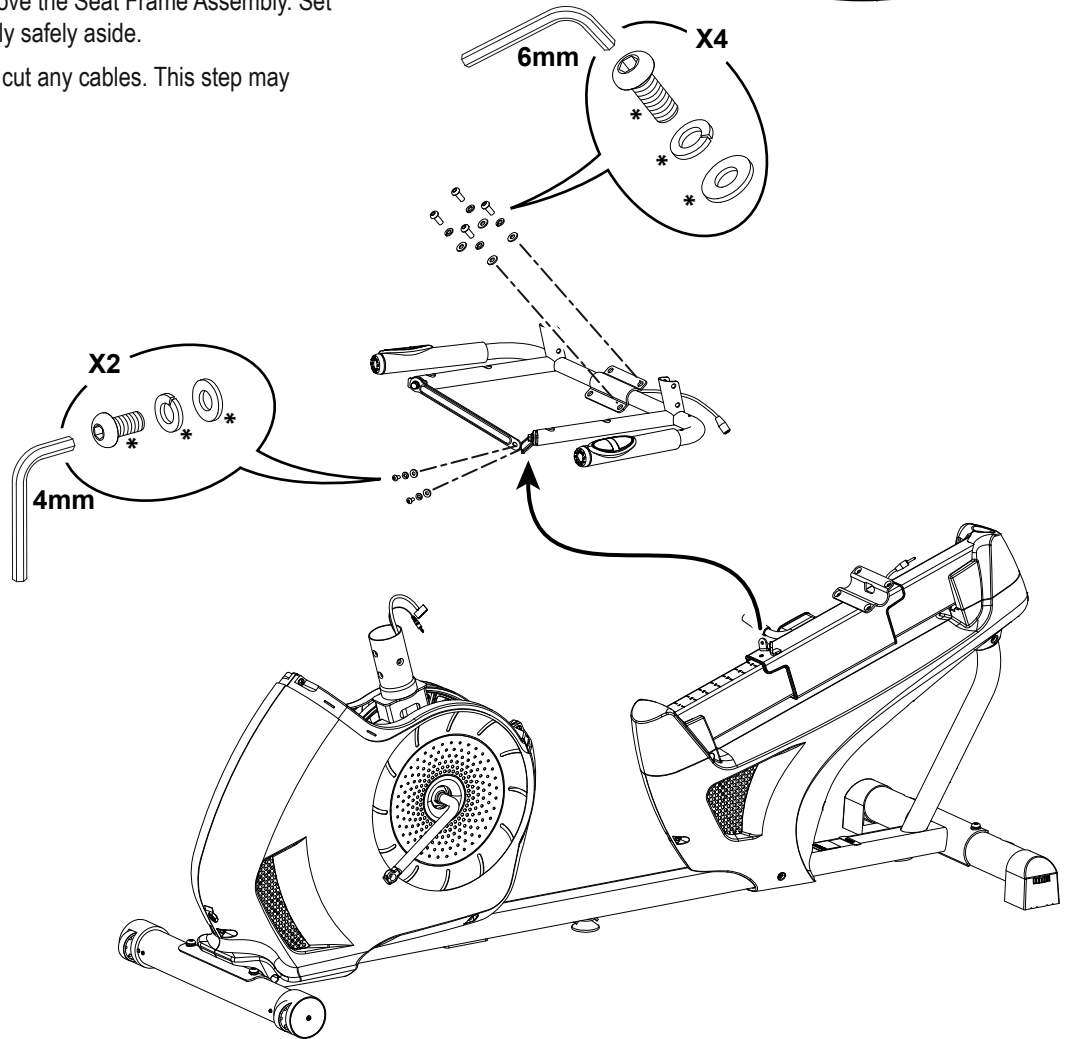

8. Using a #2 Phillips screwdriver, loosen and remove the screw that secures the front Seat Rail End Cap. Bend the edges of the rear Seat Rail End Cap to disengage the inside tabs from the Main Assembly, and remove. Set the hardware and Caps safely aside for reassembly.

9. Using a #2 Phillips screwdriver, remove the screws (indicated) that secure the Left Rear Shroud. Remove the bottom screws first, and then the top screws. Slowly remove the Left Shroud. Set the hardware and Left Shroud safely aside for reassembly.

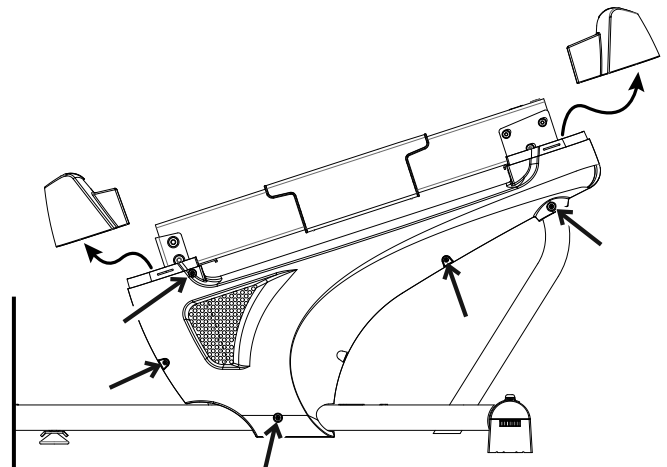

10. Using a #2 Phillips screwdriver, remove the screws that secure the Right Rear Shroud. Slowly remove the Right Shroud. Set the hardware and Right Shroud safely aside for reassembly.

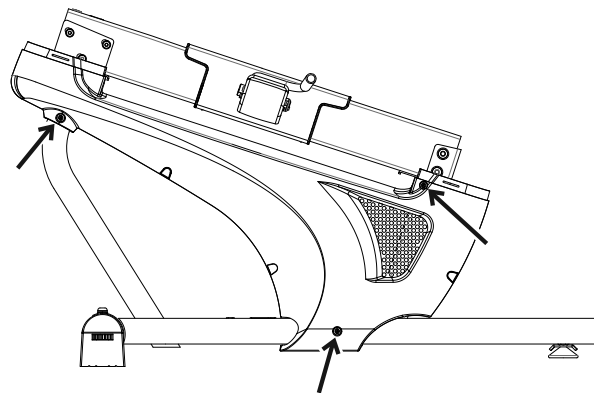

11. Using a 6mm hex wrench, loosen and remove the indicated hardware from both sides of the Seat Rail. Set the hardware safely aside.

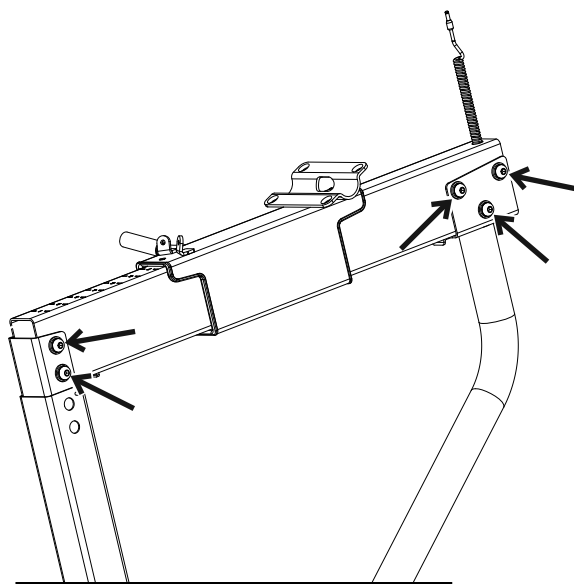

12. Carefully remove the Seat Rail Assembly slightly from the Frame, and disconnect the Heart Rate Cables. Set the Seat Rail Assembly safely aside.

NOTICE: Do not pinch or cut any cables. This step may require two people.

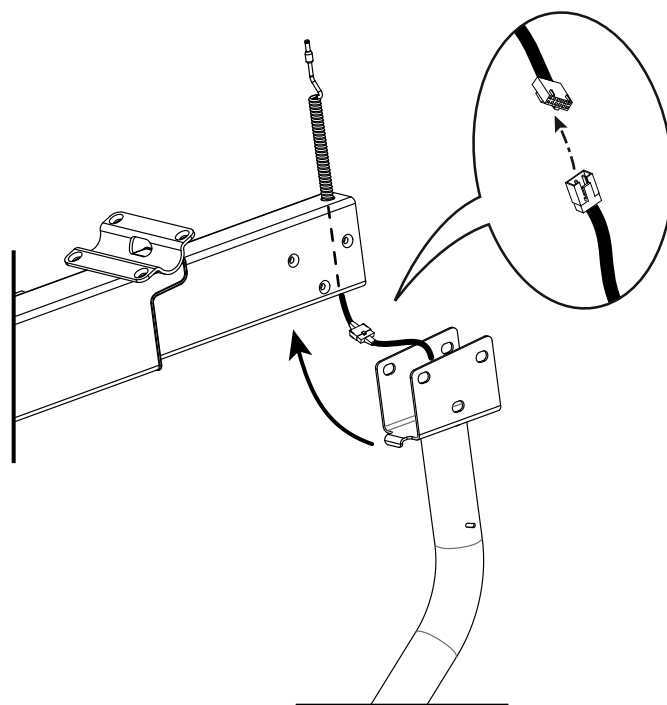

13. Installation is the reverse procedure.

NOTICE: Be sure not to pinch or cut the cables. Hand tighten all hardware first, then fully tighten it.

Put the Left Shroud in position first to align the screws for the Right Shroud. Install the top screws first.

Note: Self-tapping screws attach the Shrouds to the Frame.

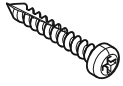

NOTICE: Be sure not to pinch or cut the cables. Be sure the tabs in the Top Shroud snap into the Main Assembly.

Hand tighten all hardware first, then fully tighten it. Be sure the cables are tucked inside the Top Cap.

14. Final Inspection

Inspect your machine to ensure that all hardware is tight and components are properly assembled.



Do not use until the machine has been fully assembled and inspected for correct performance in accordance with the Owner's Manual.

NOTICE: This document provides instructions for the replacement of the Servo Motor on the Schwinn™ 230 / 510R Recumbent Bikes.

If you need assistance, please contact Customer Service (if purchased in US/Canada) or your local distributor (if purchased outside US/Canada). To find your local distributor, go to: www.nautilusinternational.com

⚠ This icon means a potentially hazardous situation which, if not avoided, could result in death or serious injury. Read and understand all Warnings on this machine.

Nautilus, Inc., www.NautilusInc.com, 5415 Centerpoint Parkway, Groveport, OH 43125 U.S.A. - Customer Service: North America (800) 605-3369, csnls@nautilus.com | outside U.S. www.nautilusinternational.com | Printed in China | © 2022 Nautilus, Inc. | Schwinn and the Schwinn logo are trademarks owned or licensed by Nautilus, Inc., registered or otherwise protected by common law in the United States and other nations. | **ORIGINAL DOCUMENT - ENGLISH VERSION ONLY**

Important Safety Instructions - Before servicing or using this equipment, obey the following warnings:

⚠ This icon means a potentially hazardous situation which, if not avoided, could result in death or serious injury. Read and understand all Warnings on this machine.

Disconnect all power to the machine before you service it.

- Read and understand the Part Replacement Procedure before working on the machine. Failure to obey the instructions and safety warnings could cause injury to the service technician or bystanders.
- Keep bystanders and children away from the product being serviced at all times.
- Make sure that the repair is done in an appropriate work space away from foot traffic and exposure to bystanders.
- Some components of the equipment can be heavy or awkward. Enlist the service of a second person when you do maintenance steps involving these components. Do not try to do heavy or awkward steps on your own.
- If replacement parts are necessary, use only genuine Nautilus replacement parts and hardware. Failure to use genuine replacement parts can cause a risk to users, keep the machine from operating correctly and void the warranty.
- Be sure that all warning stickers and instructional placards applied to the product stay present and in good condition when doing maintenance or replacing components. If at any time the Warning labels become loose, unreadable or dislodged, replace the labels. If purchased in US/Canada, contact Customer Service for replacement labels. If purchased outside US/Canada, contact your local distributor for them.
- Do not try to change the design or functionality of the machine being serviced as this can adversely affect user safety.
- Do not use the machine until all shrouds, instructions, warning labels and correct functionality have been verified and tested for correct performance.

• SAVE THESE INSTRUCTIONS.

Tools Required (not included)

#2 Phillips screwdriver 

Needlenose pliers 

Small flathead screwdriver 

7 mm open end wrench 

Pedal wrench or 15mm open end wrench 

3' (0.9m) length of string

2.5" x 10" cardboard and tape

Utility knife or scissors to cut zipties
Zipties



! Disconnect all power to the machine before you service it.

Note: Your machine may not match the image. For reference only.

1. Loosen and remove the Pedals.

Note: The Left Pedal is reverse-threaded. Orientation is based from a seated position on the bike. The Left Pedal has an "L", the Right Pedal an "R".

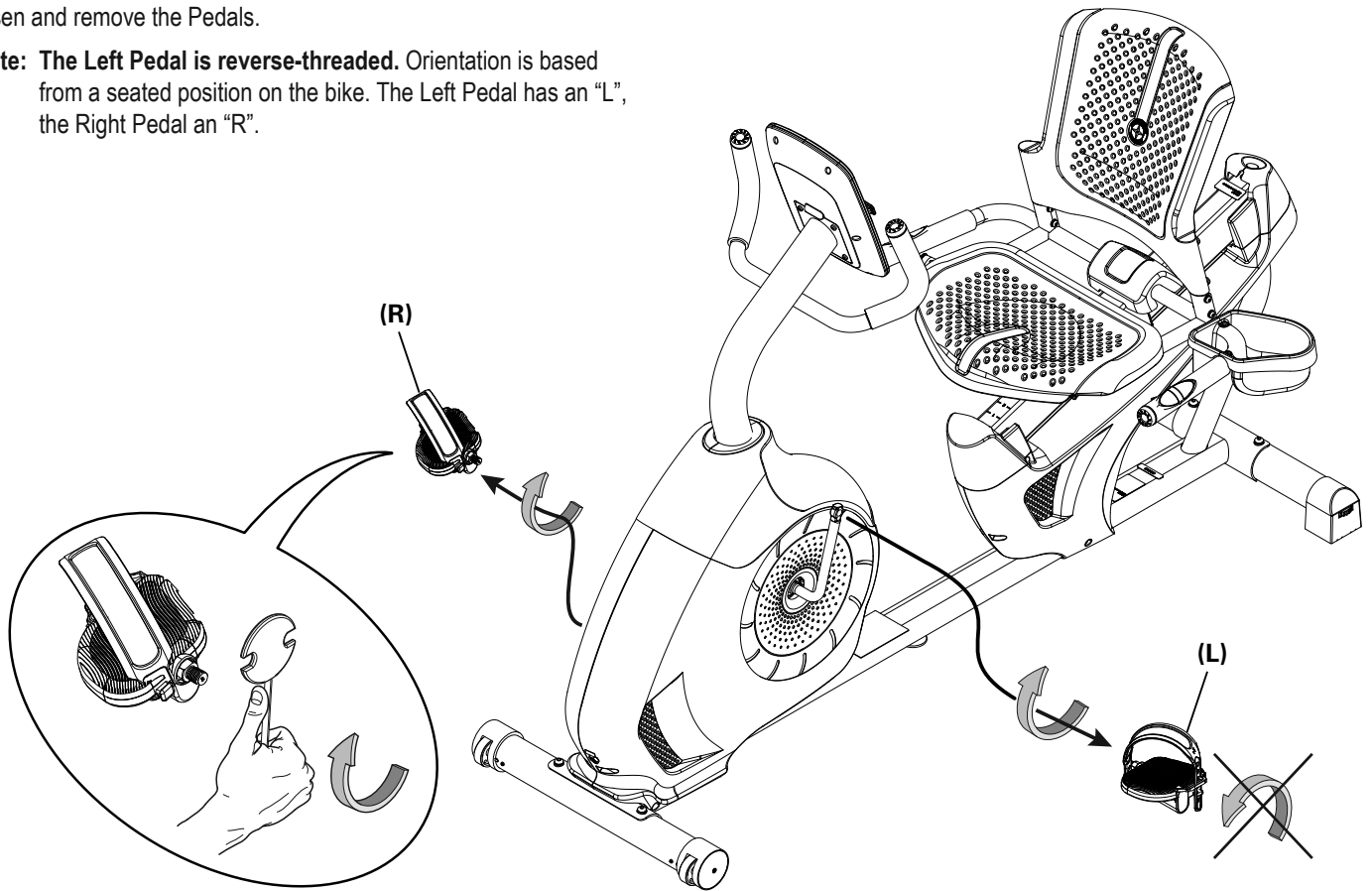

2. Gently remove the Shroud Cap from the Upper Shroud, and remove it from the Console Mast.

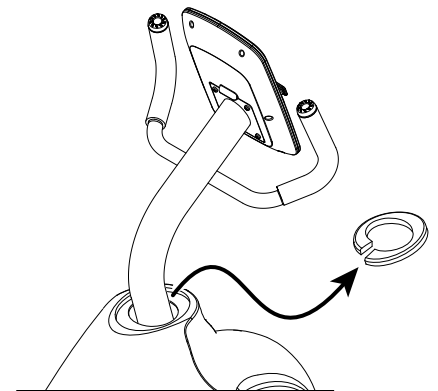

3. Flex the edges of the Upper Shroud to disengage the inside tabs from the Main Assembly, and slide it up the Console Mast.

4. Using a 6mm hex wrench, remove the indicated hardware from the Console Mast. Slightly pull the Console Mast upward, and disconnect the cables. Set the hardware and Upper Shroud safely aside for reassembly. Discard the old Console Mast.

NOTICE: Do not pinch or cut the cables.
This step may require two people.

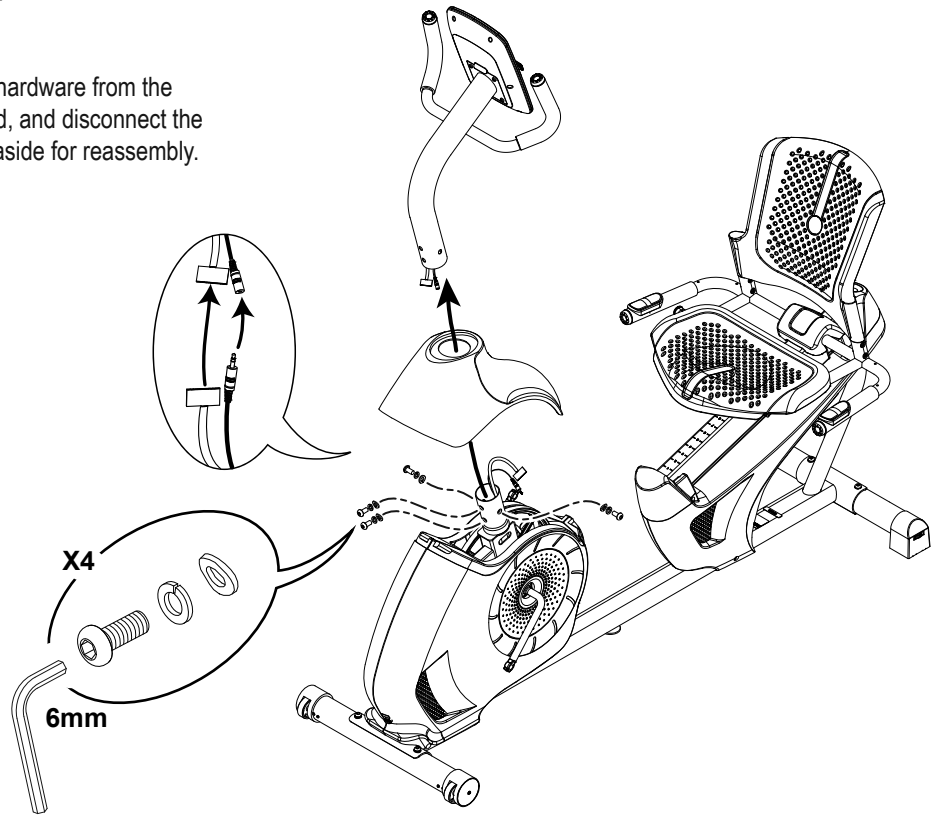

5. Using a #2 Phillips Screwdriver, remove the 6 screws (indicated) that secure the Left Main Shroud. Remove the bottom screws first, and then the top screws. Set the hardware safely aside for reassembly. Slowly remove the Left Main Shroud.

Note: The Power Inlet Cable (A1) is attached to the inside of the Left Main Shroud. Be sure not to pinch or cut the cable by placing the Left Main Shroud close to the side of the machine.

NOTICE: Do not pinch or cut the cables.

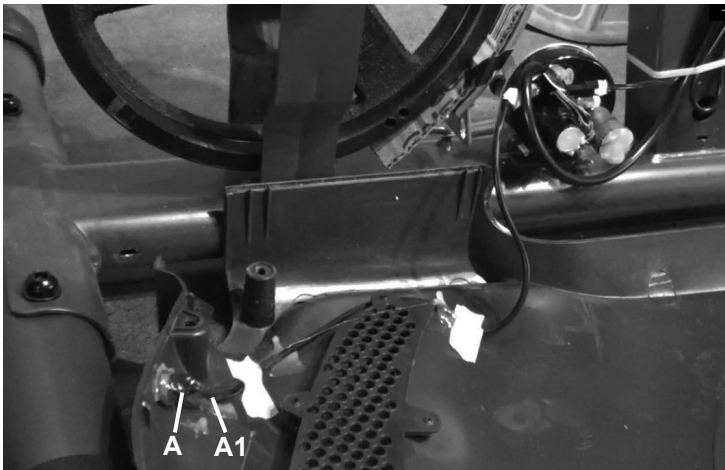
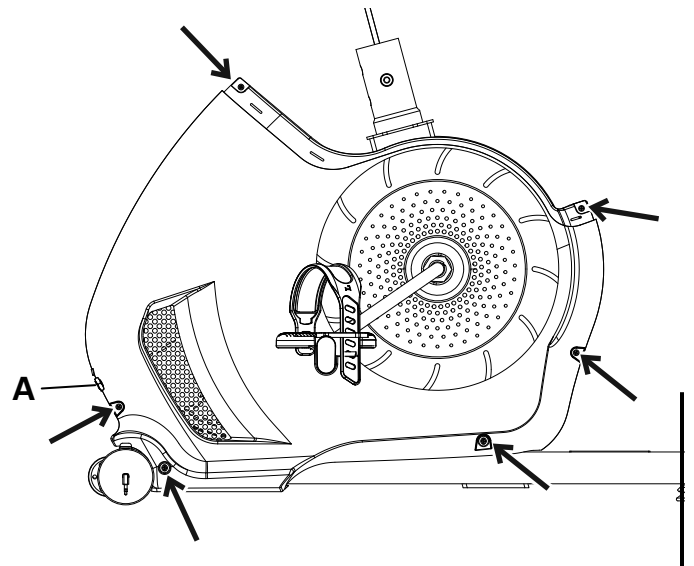

6. Insert 2.5" x 10" cardboard between the Brake Magnet (C) and the Flywheel (B), and tape the cardboard to the Brake Magnet.

Note: Be sure the cardboard covers all of the Brake Magnet.

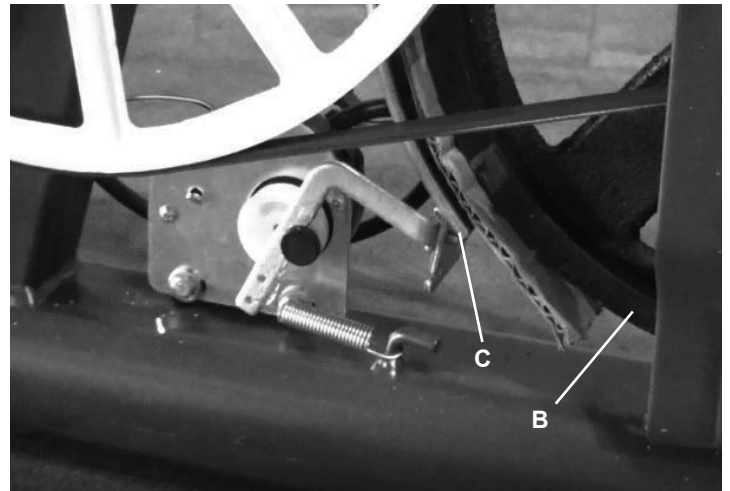

7. Observe the cable routing to the wiring harness (D) on your machine. Disconnect the Speed Sensor Cable (E) and Power Inlet Cable (F) from the wiring harness.



8. Tie the length of string to the end of the lower Console Cable (G) at the top of the Mast mount. Pull the cable and string down through the hole (H) on the side of the Frame so that the string extends through the Frame. Remove the zipties that attach the lower Console Cable to the Frame.

9. Untie the string from the Console Cable (G).

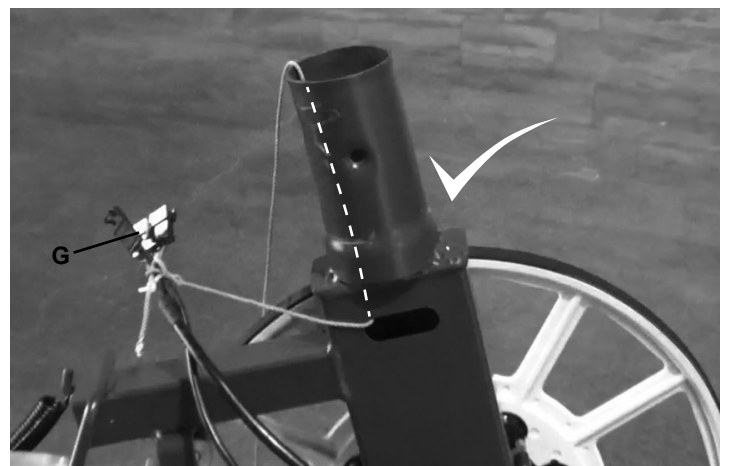

10. Use the pliers to unhook the Tension Spring (J) from the Main Frame. Pull back and release the Magnet Arm (K) enough to disengage it from the Motor Pulley Shaft (L).

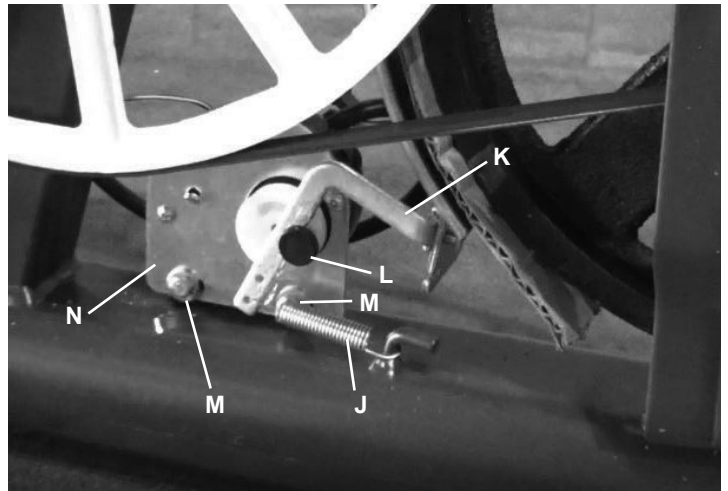

11. Loosen and remove the two hex head bolts (M) from the Servo Motor (N).

12. Remove the Servo Motor (N). Discard the old Servo Motor.

13. Install the new Servo Motor. Installation is the reverse procedure.

NOTICE: Do not touch the Potentiometer (P). Do not pinch or cut the cables.

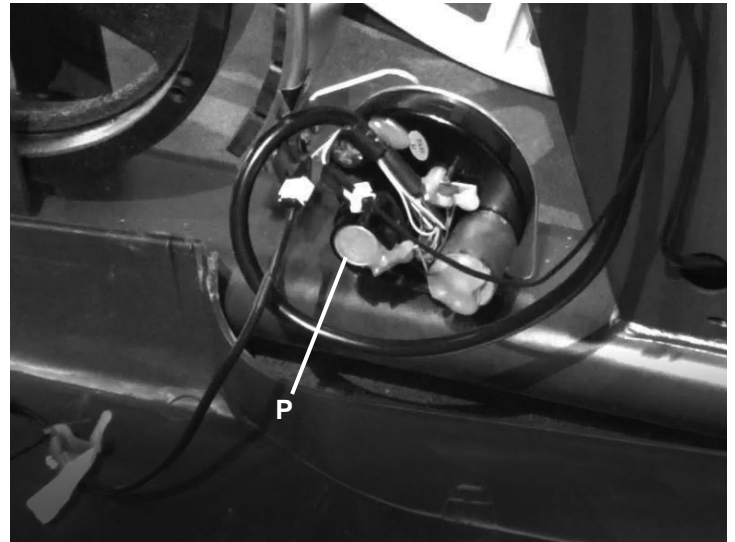

14. Tie the end of the string at the hole (H) in the Mast to the end of the Console Cable (G) on the new Servo Motor. Carefully pull the cable through the hole to the top of the Mast mount. Untie the string and discard it.

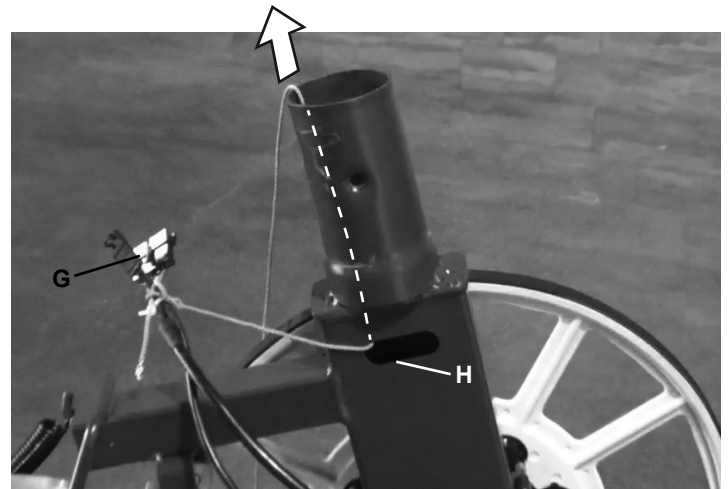

15. Reinstall the Console Mast and Top Shroud. Installation is the reverse procedure.

16. Turn the power on. by plugging in the machine.



Machine is on. Current is active. There is risk of electrical shock.

17. Use the console to set the resistance to the highest level. Unplug the machine.



Disconnect all power and allow to sit for 5 minutes.

18. If correctly calibrated, the Brake Magnet should be within 3.0 mm (1/8") of the Flywheel. If not, it will need to be adjusted. To adjust the Brake, loosen the 2 hex head bolts (M) and move the Servo Motor assembly (N) until the closest point on the Brake Magnet (C) is within 3.0 mm (1/8") of the Flywheel (B). Tighten the bolts.

Note: If the cardboard is not 3mm (1/8") thick, you can use the pages of a paperback book to measure the gap. Approximately 36 pages (sheets) = 3mm.

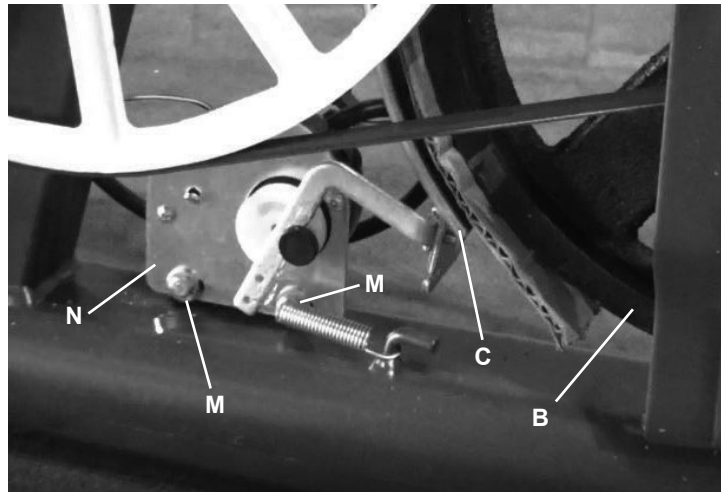

19. Installation is the reverse procedure. Put the Left Shroud in position first to align the screws for the Right Shroud. Install the top screws first.

Note: Self-tapping screws attach the Shrouds to the Frame.

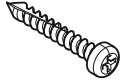

NOTICE: Be sure not to pinch or cut any cables. Be sure the tabs in the Top Shroud snap into the Main Assembly.

20. Attach the Pedals. Start the Pedals by hand, and then fully tighten them with the Pedal Wrench. The Pedals must be fully tightened.

! If the threads strip due to improper installation, then the Pedals can disengage from the bike and/or break while under usage, which can result in serious injury to the user.

Note: The Left Pedal is reverse-threaded. Be sure to attach Pedals on the correct side of the Bike. Orientation is based from a seated position on the bike. The Left Pedal has an "L", the Right Pedal an "R".

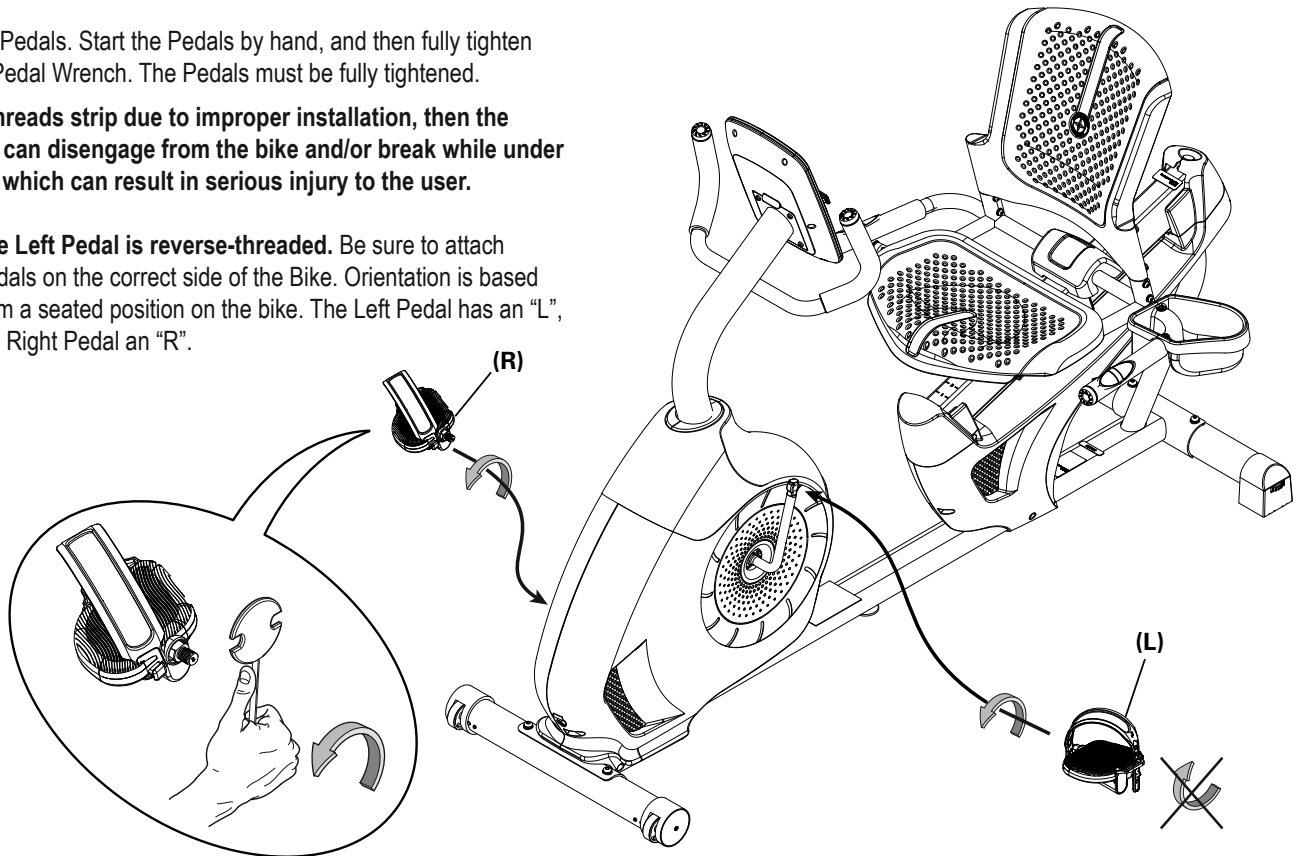

21. Final Inspection

Inspect your machine to ensure that all hardware is tight and components are properly assembled.

! Do not use until the machine has been fully assembled and inspected for correct performance in accordance with the Owner's Manual.

NOTICE: This document provides instructions for the replacement of the Shrouds on the Schwinn™ 230 / 510R Recumbent Bikes.

If you need assistance, please contact Customer Service (if purchased in US/Canada) or your local distributor (if purchased outside US/Canada). To find your local distributor, go to: www.nautilusinternational.com

⚠ This icon means a potentially hazardous situation which, if not avoided, could result in death or serious injury. Read and understand all Warnings on this machine.

Nautilus, Inc., www.NautilusInc.com, 5415 Centerpoint Parkway, Groveport, OH 43125 U.S.A. - Customer Service: North America (800) 605-3369, csnls@nautilus.com | outside U.S. www.nautilusinternational.com | Printed in China | © 2022 Nautilus, Inc. | Schwinn and the Schwinn logo are trademarks owned or licensed by Nautilus, Inc., registered or otherwise protected by common law in the United States and other nations. | **ORIGINAL DOCUMENT - ENGLISH VERSION ONLY**

Important Safety Instructions - Before servicing or using this equipment, obey the following warnings:

⚠ This icon means a potentially hazardous situation which, if not avoided, could result in death or serious injury. Read and understand all Warnings on this machine.

Disconnect all power to the machine before you service it.

- Read and understand the Part Replacement Procedure before working on the machine. Failure to obey the instructions and safety warnings could cause injury to the service technician or bystanders.
- Keep bystanders and children away from the product being serviced at all times.
- Make sure that the repair is done in an appropriate work space away from foot traffic and exposure to bystanders.
- Some components of the equipment can be heavy or awkward. Enlist the service of a second person when you do maintenance steps involving these components. Do not try to do heavy or awkward steps on your own.
- If replacement parts are necessary, use only genuine Nautilus replacement parts and hardware. Failure to use genuine replacement parts can cause a risk to users, keep the machine from operating correctly and void the warranty.
- Be sure that all warning stickers and instructional placards applied to the product stay present and in good condition when doing maintenance or replacing components. If at any time the Warning labels become loose, unreadable or dislodged, replace the labels. If purchased in US/Canada, contact Customer Service for replacement labels. If purchased outside US/Canada, contact your local distributor for them.
- Do not try to change the design or functionality of the machine being serviced as this can adversely affect user safety.
- Do not use the machine until all shrouds, instructions, warning labels and correct functionality have been verified and tested for correct performance.

• SAVE THESE INSTRUCTIONS.

Tools Required (not included)

#2 Phillips screwdriver



6mm hex wrench

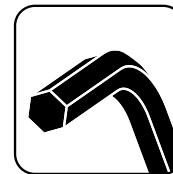

Flathead screwdriver



Pedal wrench or 15mm open end wrench



! Disconnect all power to the machine before you service it.

Note: Your machine may not match the image. For reference only.

1. Loosen and remove the Pedals.

Note: The Left Pedal is reverse-threaded. Orientation is based from a seated position on the bike. The Left Pedal has an "L", the Right Pedal an "R".

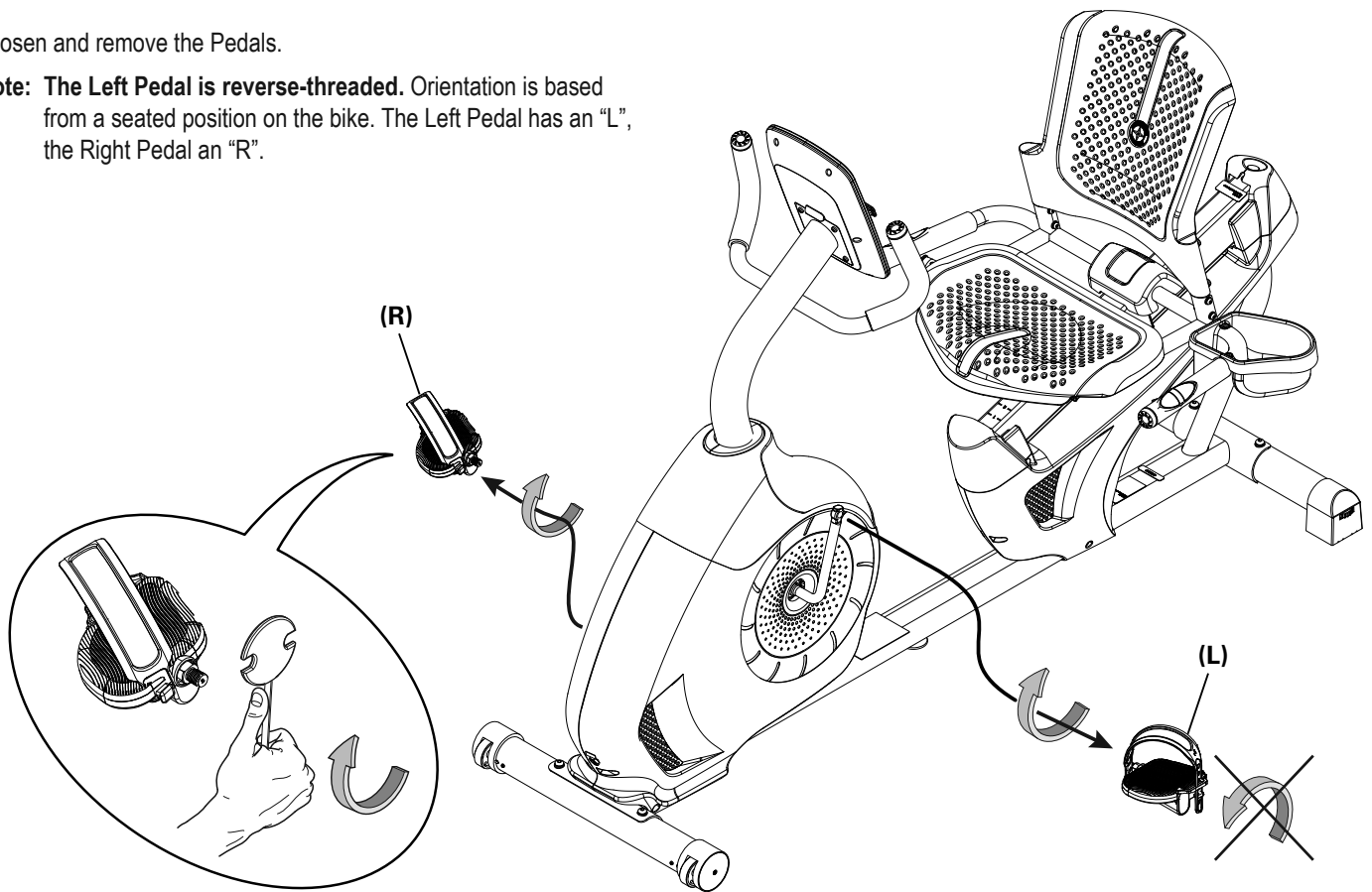

3. Gently remove the Shroud Cap from the Upper Shroud, and remove it from the Console Mast.

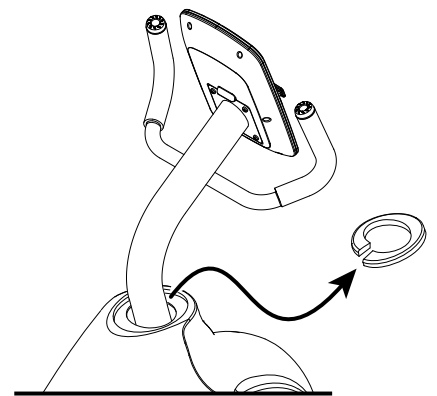

4. Flex the edges of the Upper Shroud to disengage the inside tabs from the Main Assembly, and slide it up the Console Mast.

5. Using a 6mm hex wrench, remove the indicated hardware from the Console Mast. Slightly pull the Console Mast upward, and disconnect the cables. Set the hardware, Shroud Cap, and Upper Shroud safely aside for reassembly. Discard the old Console Mast.

NOTICE: Do not pinch or cut the cables.
This step may require two people.

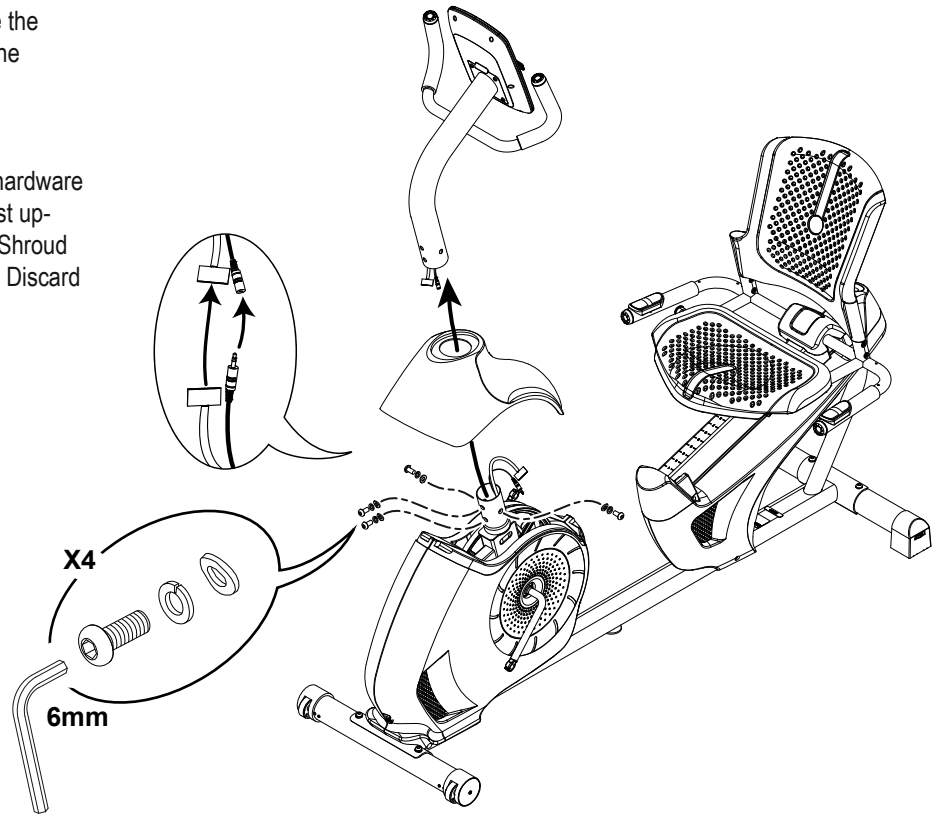

6. Using a #2 Phillips Screwdriver, remove the 6 screws (indicated) that secure the Left Main Shroud. Remove the bottom screws first, and then the top screws. Slowly remove the Left Main Shroud. Set the hardware and Shroud safely aside for reassembly.

Note: Find the Power Inlet (A) in the Left Shroud. Disconnect the Power Inlet cable (A1) from the wiring harness (B).

NOTICE: Do not pinch or cut the cables.

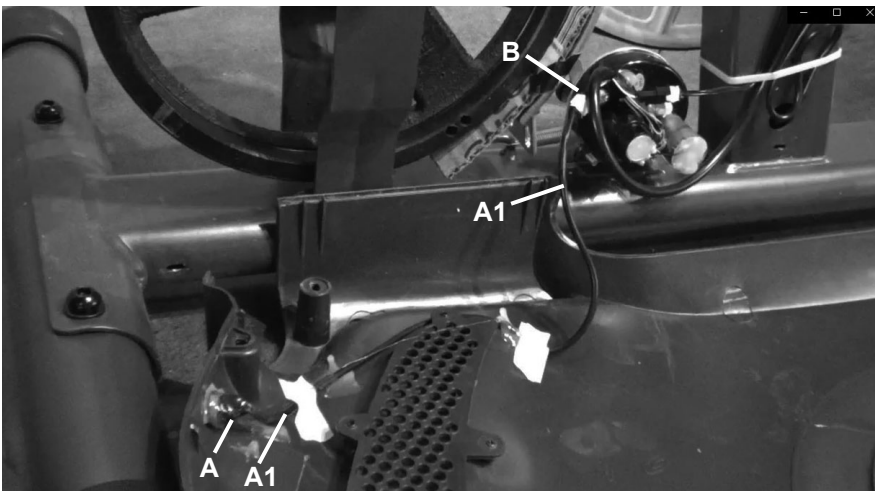
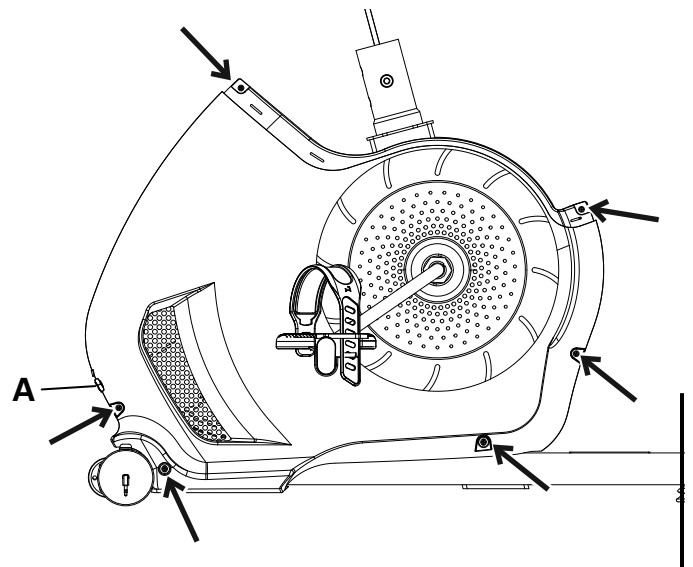

7. Using a #2 Phillips Screwdriver, remove the 2 screws that secure the Right Main Shroud. Slowly remove the Right Main Shroud. Set the hardware and Shroud safely aside for reassembly.

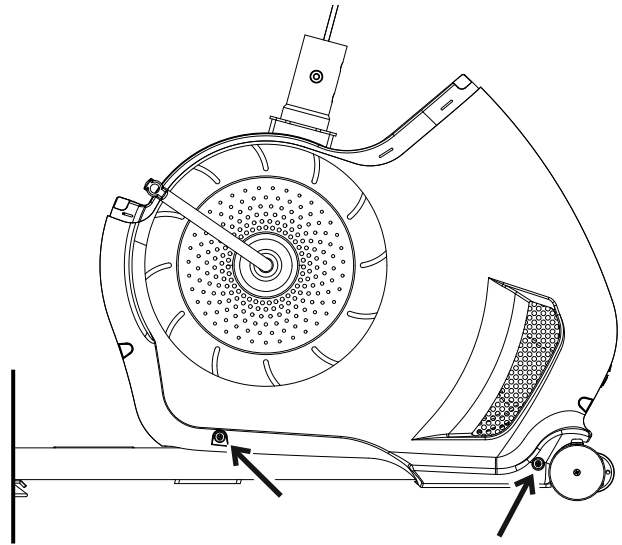

To remove the Rear Shrouds:.

8. Remove the Front and Rear Top Caps: Bend the edges of the Top Caps to disengage the inside tabs from the Main Assembly, and remove. Set the Top Caps safely aside for reassembly.

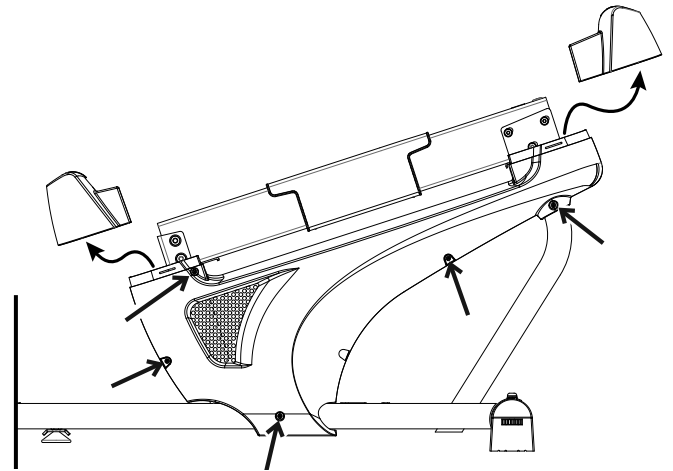

9. Using a #2 Phillips Screwdriver, remove the screws (indicated) that secure the Left Rear Shroud. Remove the bottom screws first, and then the top screws. Slowly remove the Left Shroud. Set the hardware and Left Shroud safely aside for reassembly.

10. Using a #2 Phillips Screwdriver, remove the screws that secure the Right Rear Shroud. Slowly remove the Right Shroud. Set the hardware and Right Shroud safely aside for reassembly.

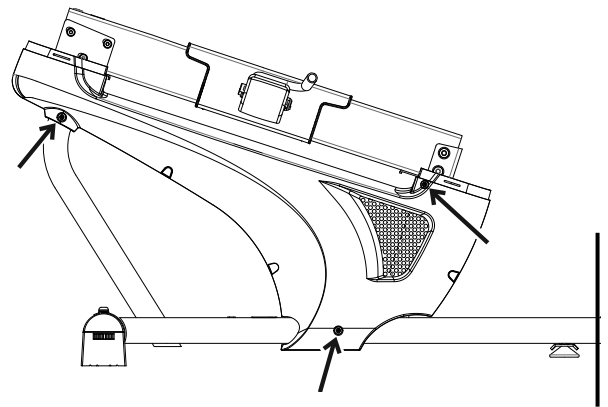

11. Installation is the reverse procedure. Put the Left Shroud in position first to align the screws for the Right Shroud. Install the top screws first.

Note: Self-tapping screws attach the Shrouds to the Frame.

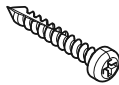

NOTICE: Be sure not to pinch or cut any cables. Be sure the tabs in the Top Shroud snap into the Main Assembly.

12. Attach the Pedals. Start the Pedals by hand, and then fully tighten them with the Pedal Wrench. The Pedals must be fully tightened.

! If the threads strip due to improper installation, then the Pedals can disengage from the bike and/or break while under usage, which can result in serious injury to the user.

Note: The Left Pedal is reverse-threaded. Be sure to attach Pedals on the correct side of the Bike. Orientation is based from a seated position on the bike. The Left Pedal has an "L", the Right Pedal an "R".

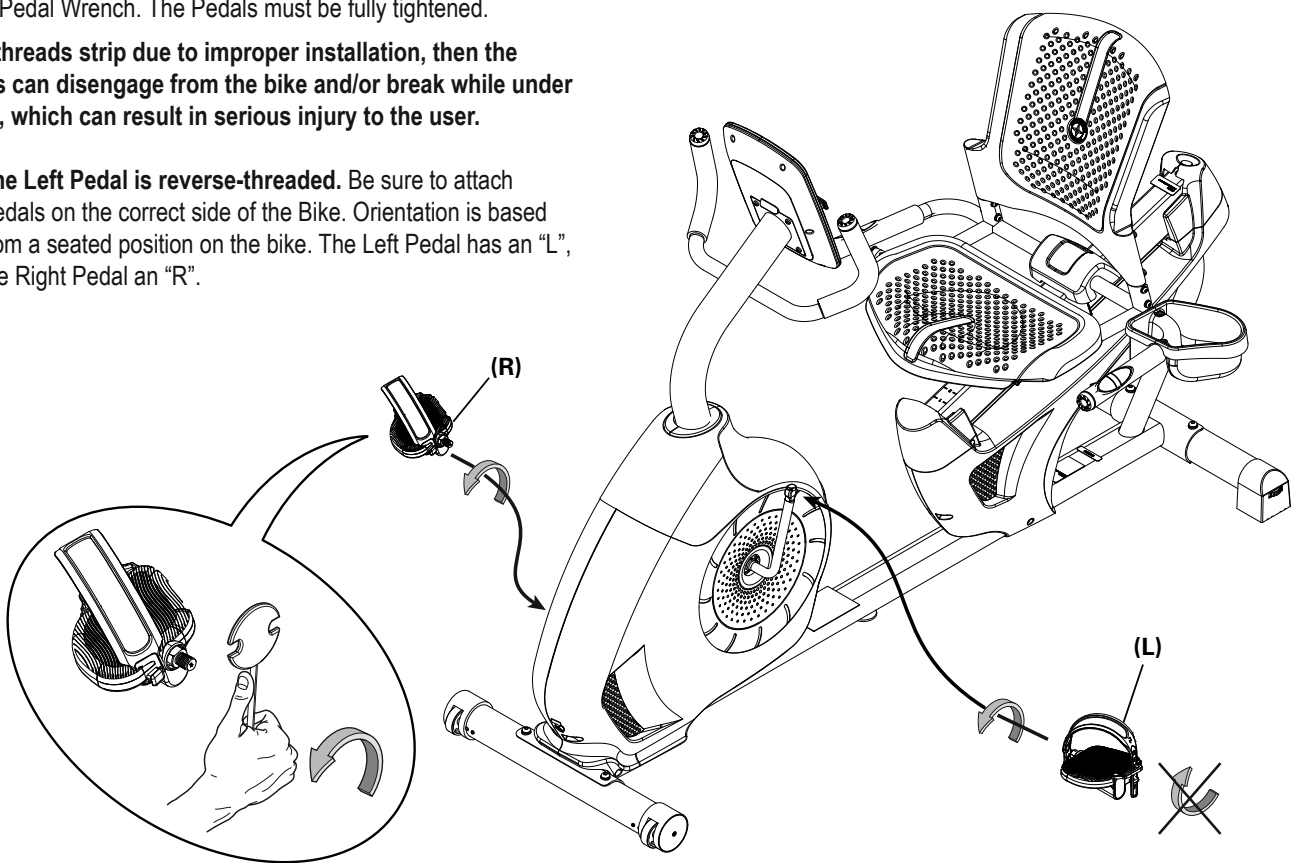

13. Final Inspection

Inspect your machine to ensure that all hardware is tight and components are properly assembled.

! Do not use until the machine has been fully assembled and inspected for correct performance in accordance with the Owner's Manual.

NOTICE: This document provides instructions for the replacement of the Transport Wheels on the Schwinn™ 130 / 510U Upright Bikes and 230 / 510R Recumbent Bikes.

If you need assistance, please contact Customer Service (if purchased in US/Canada) or your local distributor (if purchased outside US/Canada). To find your local distributor, go to: www.nautilusinternational.com

 **This icon means a potentially hazardous situation which, if not avoided, could result in death or serious injury. Read and understand all Warnings on this machine.**

Nautilus, Inc., www.NautilusInc.com, 5415 Centerpoint Parkway, Groveport, OH 43125 U.S.A. - Customer Service: North America (800) 605-3369, csnls@nautilus.com | outside U.S. www.nautilusinternational.com | Printed in China | © 2022 Nautilus, Inc. | Schwinn and the Schwinn logo are trademarks owned or licensed by Nautilus, Inc., registered or otherwise protected by common law in the United States and other nations. | **ORIGINAL DOCUMENT - ENGLISH VERSION ONLY**

Important Safety Instructions - Before servicing or using this equipment, obey the following warnings:

 **This icon means a potentially hazardous situation which, if not avoided, could result in death or serious injury. Read and understand all Warnings on this machine.**

Disconnect all power to the machine before you service it.

- Read and understand the Part Replacement Procedure before working on the machine. Failure to obey the instructions and safety warnings could cause injury to the service technician or bystanders.
- Keep bystanders and children away from the product being serviced at all times.
- Make sure that the repair is done in an appropriate work space away from foot traffic and exposure to bystanders.
- Some components of the equipment can be heavy or awkward. Enlist the service of a second person when you do maintenance steps involving these components. Do not try to do heavy or awkward steps on your own.
- If replacement parts are necessary, use only genuine Nautilus replacement parts and hardware. Failure to use genuine replacement parts can cause a risk to users, keep the machine from operating correctly and void the warranty.
- Be sure that all warning stickers and instructional placards applied to the product stay present and in good condition when doing maintenance or replacing components. If at any time the Warning labels become loose, unreadable or dislodged, replace the labels. If purchased in US/Canada, contact Customer Service for replacement labels. If purchased outside US/Canada, contact your local distributor for them.
- Do not try to change the design or functionality of the machine being serviced as this can adversely affect user safety.
- Do not use the machine until all shrouds, instructions, warning labels and correct functionality have been verified and tested for correct performance.

•SAVE THESE INSTRUCTIONS.

Tools Required (not included)

#2 Phillips screwdriver

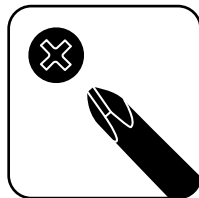

Note: Your machine may not match the image. For reference only.

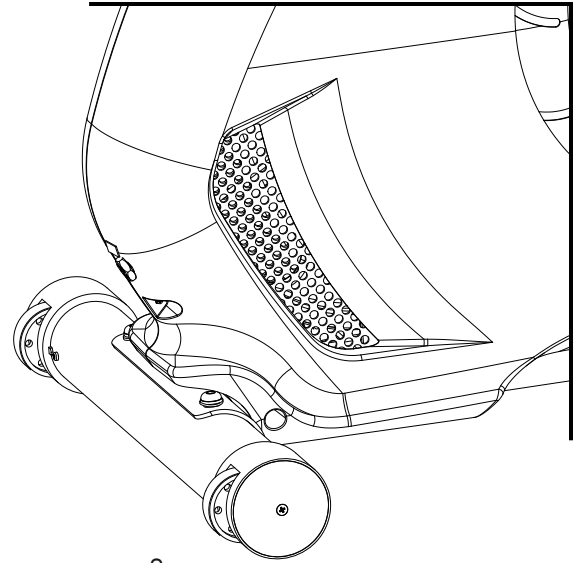

1. Loosen and remove the indicated screw from the old Transport Wheel Assembly, and set it safely aside for reassembly. Remove the old Transport Wheel Assembly from the Front Stabilizer, and discard.

2. Install the new Transport Wheel Assembly.

Note: Be sure the plastic Alignment Tab on the Transport Wheel Assembly goes into the slot at the end of the Front Stabilizer.

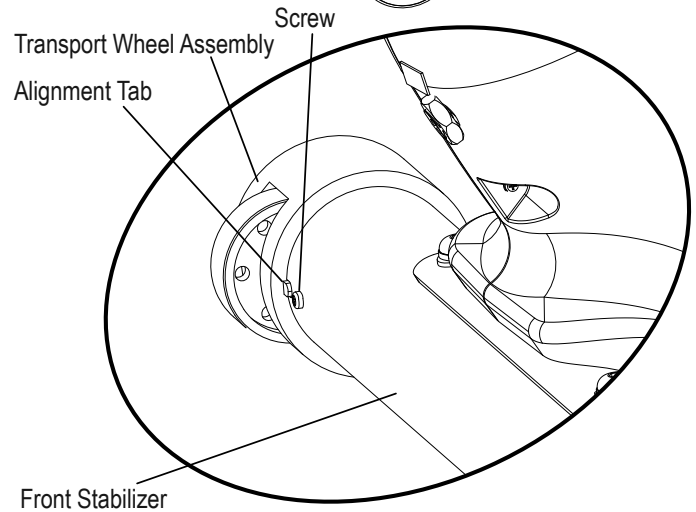

3. Final Inspection

Inspect your machine to ensure that all hardware is tight and components are properly assembled.



Do not use until the machine has been fully assembled and inspected for correct performance in accordance with the Owner's Manual.