

Schwinn AirDyne AD Pro: I need help installing the handlebars on my bike

ID: 13151.1

Follow this troubleshooting guide to help resolve issues during handlebar installation on the Schwinn AirDyne AD Pro.

Some common complaints may include:

- Can't install handlebars
- Handlebars don't fit
- Difficulty with handlebar installation

Follow these steps to troubleshoot the issue

Tools you may need:

Flathead screwdriver
6mm hex/Allen wrench, or the wrench from the hardware card included with your machine

1. Refer to the "Attach Handlebar Arms to Frame Assembly" step in the [assembly manual](#). Use a 6mm Allen wrench to remove the two screws from the bottom of the handlebar (**reference 1**).

(Reference 1)

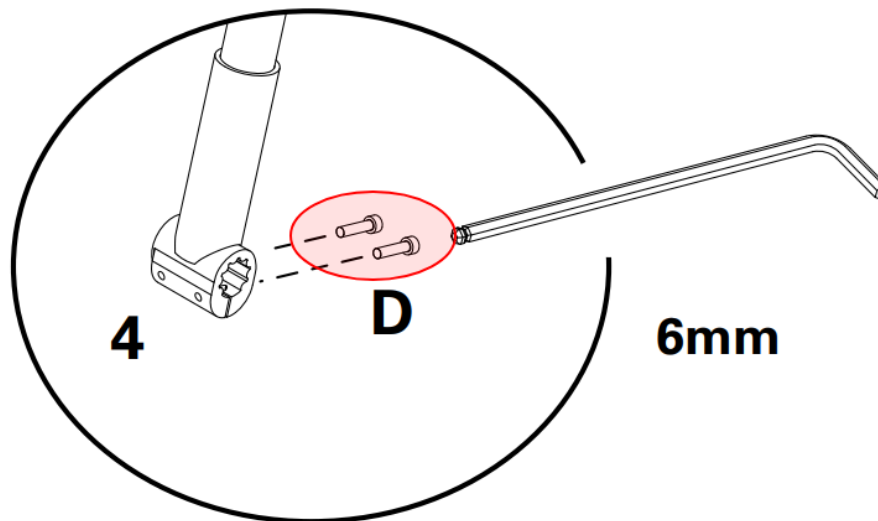

Remove the 2 screws at the bottom of the handlebar as shown.

2. Make sure that the handlebars are aligned properly during assembly. The opening of the handlebar has a very specific shape and can only be assembled when the opening and axle of the handlebar are properly lined up (**reference 2**).

(Reference 2)

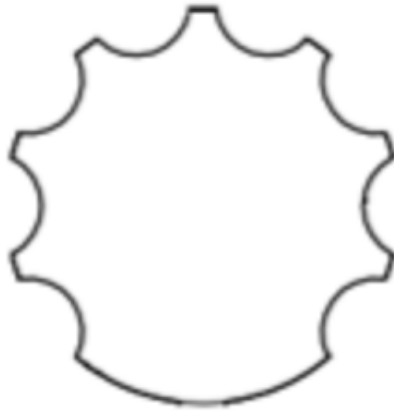

The opening of the handlebar and the axle of the pivot shaft is shaped so installation can only be performed one way. The opening/axle has 7 points at the top and a smooth, curved bottom.

3. Locate the clamp at the bottom of the handlebar that has a vertical opening (**reference 3**). Use a flathead screwdriver to *very carefully* pry the opening up slightly. Do not pry so hard that the clamp does not remain closed after. You may need an additional person to complete this step (one to hold the handlebar and the other to manipulate the clamp opening).

(Reference 3)

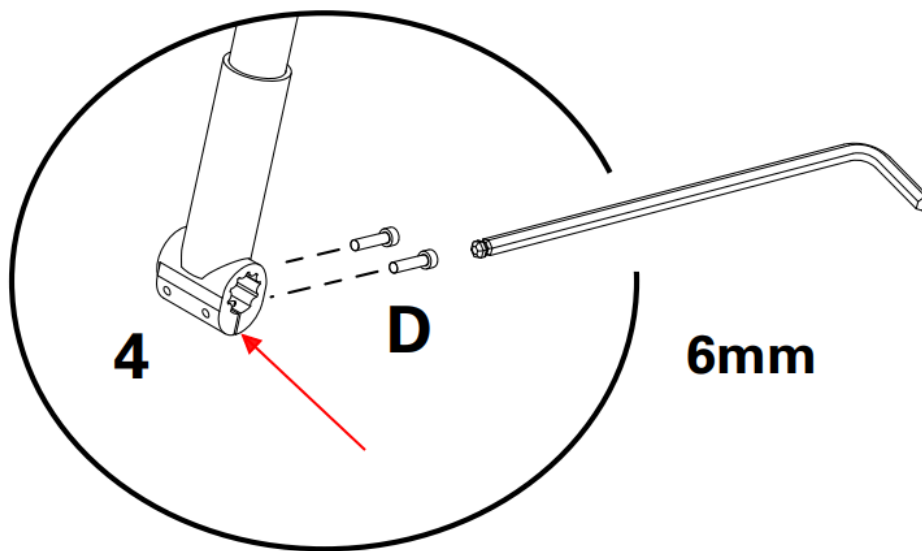

Very gently pry open the vertical opening on the clamp, indicated by the red arrow.

4. Align the smooth curve on the handlebar with the smooth curve on the pivot shaft (**reference 4**) and make sure that the indents are exactly aligned. Gently rock the handlebar forward and backward until the handlebar is fully seated on the shaft. Make sure that the handlebar slides on all the way.

(Reference 4)

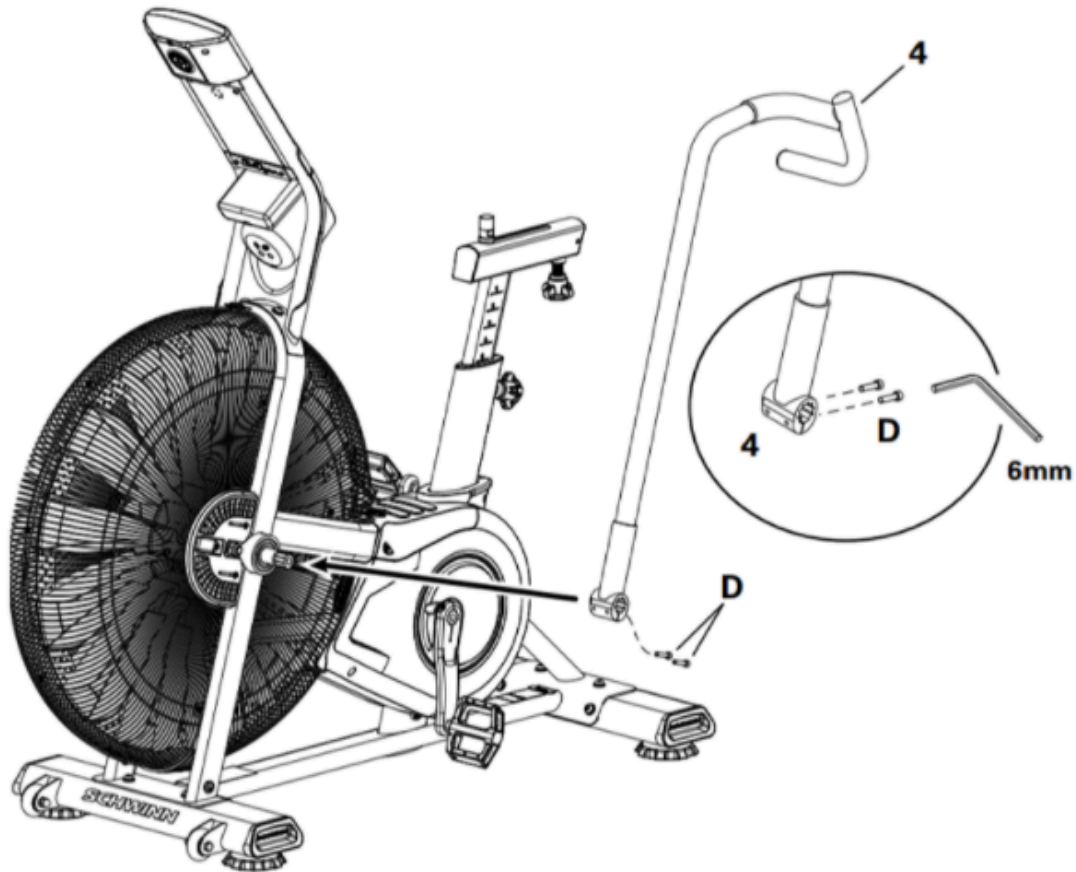
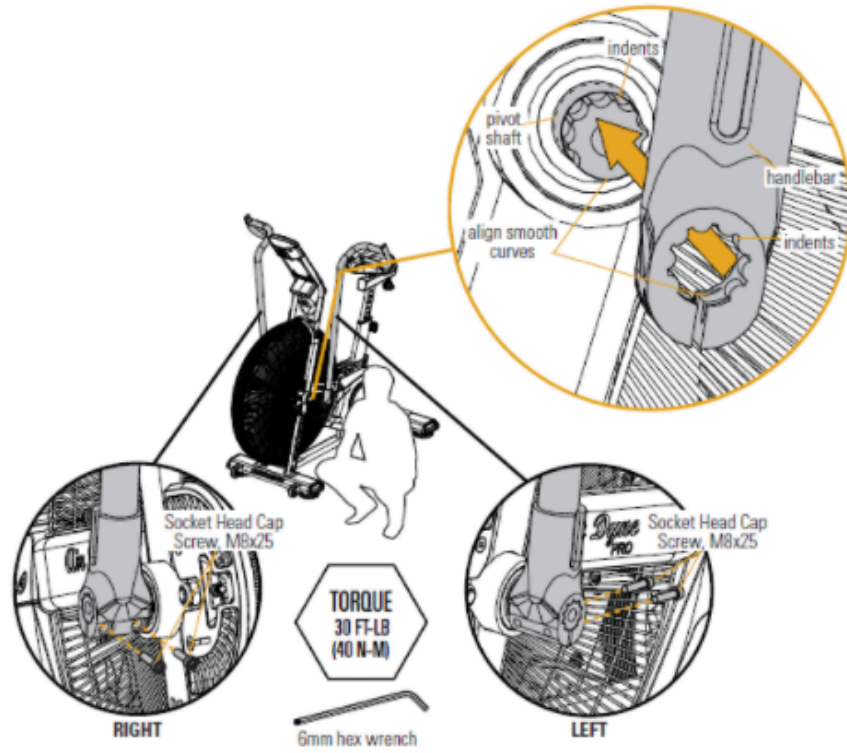

The handlebar opening and axle installation process is pictured in the upper right corner of this image.

- Once the handlebar is fully seated, tighten the two screws at the bottom of the handlebar using a 6mm Allen wrench. The screws should be torqued to 40 Nm or 30 ft/lb [\[13151.A\]](#). Retighten the screws if the handlebars seem loose.

Need additional assistance?

1 Customer Care Contact Information

Please contact Customer Care at [1-800-605-3369](tel:1-800-605-3369) for additional help or to order replacement parts. Some replacement parts may also be available for purchase [online here](#). A list of part numbers referenced within this guide can be located at the bottom of this page.

Customer Care - Hours of Operation:

Monday - Friday 6:00am - 5:00pm PST

The replacement part will be provided to you at no cost assuming your machine meets the warranty eligibility requirements. A Customer Care Agent will be able to assess your current warranty eligibility and provide you with your options.

Please note that if you did not purchase your machine directly from BowFlex, Schwinn, or Nautilus, we will need a copy of your purchase receipt in order to register your machine for warranty.

2 Contact Tech Team / Advanced Troubleshooting

If the issue was not resolved in the steps listed, contact the Tech Team or send an Advanced Troubleshooting case.

Submit a Case with case type Advanced Troubleshooting